



CMP PRODUCTS

*Incorporating Triple
Certified Products*



SEPTEMBER 2007

Industrial and Hazardous Area Cable Glands and Accessories

*Single Solution
Three Forms of Protection
Ex d / Ex e / Ex nR*

BRIEF HISTORY OF BRITISH ENGINES LIMITED

CMP Products is a division of British Engines Limited, a company registered in England, number 167542.

British Engines Limited (BEL) was founded in St. Peters, Newcastle upon Tyne in 1922, when two brothers from Glasgow, Harold and Charles Lamb established the Company. Today the Company proudly remains in the same family ownership with Mr. Alex Lamb its present chairman, the grandson of one of the founders.

The early British Engines Limited business was conducted from a building suitable for housing less than 12 employees, with marine engineering and sub-contract machining work being at the core of its activities. The Company had entered the marine engineering market when it began servicing, overhauling and reconditioning diesel engines for marine vessels. The Company's development relied largely upon the success of its customers, as it did not originally offer any of its own products, and its business was increasingly subject to sporadic fluctuation. Having identified that it was not in control of its own destiny, the Company consequently decided to employ a product development strategy, and embark on a path of diversification and significant business growth.

In 1957, cable terminating glands were introduced by British Engines Limited, that were marketed under the CMP brand. These have been continuously developed to meet increasingly difficult industry conditions, and to stay in pace with ever changing international technical standards. The CMP Products division remains a world leader in the field of cable connecting for industrial and hazardous area installations, designing, manufacturing, and distributing cable glands, adaptors, reducers, stopper plugs, breathers, drain plugs, and accessories, with a wide array of global third party certification.

Other business units of British Engines Limited were later created, including in 1962 the division known today as BEL Valves. This division designs, manufactures and supplies specialised high-pressure valves and associated actuator sets for the oil, gas and petro-chemical industries. BEL Valves has evolved into a world renowned provider of bespoke valve solutions to customer specification, which are used in the onshore and offshore industries, including the more specialised sub-sea arena.

A comprehensive range of industrial hydraulic pumps and motors was developed by what is now known as the Rotary Power division which services a variety of International markets, with customers engaged in the polyethylene pumping, mining, drilling, trenching, and agricultural machinery business. Stephenson Gobin Engineering, is a British Engines Limited division which designs, manufactures and supplies a range of electromagnetic door retainers and a variety of other control mechanisms, including electromagnetic clutches and brakes used in the automation industries. The BEL Group also includes a packaging division, Stadium Packing Services, which manufactures standard and customised packing cases, complying with the requirements for deep sea, road and air export cargo, and the exacting Ministry of Defence standards.

British Engines Limited currently occupies an area of 600,000 square feet, and employs in excess of 1000 people, the majority of which are located on the now greatly expanded St. Peters site. Company offices can also be found overseas in places such as U.S.A., U.A.E., Germany, Singapore, China, South Korea and Australia.

To ensure the company maintains its market leading position, people development is at the forefront of its activities, ensuring that individuals maximise their own potential and career aspirations in tandem with the Company's business requirements. In conjunction with its positive Human Resource Policies, the Company has maintained its "Investors in People" accolade on a consistent basis.

With the dedication of experienced personnel, continual investment in plant and machinery, allowing the Group to develop and market quality products at competitive prices, CMP Products is able to look forward to continued managed growth in the future years.



VISION STATEMENT

“ To *elevate* the *customer* to the *centre* of our activities and to employ our endeavour to bring about a *positive* experience for everyone ”

Vince Patterson - MANAGING DIRECTOR

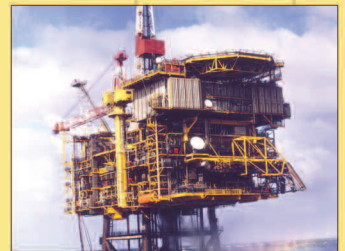

INDEX	
BRIEF COMPANY HISTORY	1
VISION STATEMENT	2
MATRIX OF INDUSTRIAL PRODUCTS	5-6
MATRIX OF HAZARDOUS AREA PRODUCTS	7-8
TECHNICAL CONTENTS LOCATOR	9-10
TECHNICAL & APPLICATION INFORMATION BASE	11-74
INDUSTRIAL CABLE GLAND PRODUCTS	75-94
CMP SOLO - LOW SMOKE & FUME RANGE - HALOGEN FREE PRODUCTS	95-98
CMP CIEL - CAST INTEGRAL EARTH LUG EQUIPPED PRODUCTS	99-104

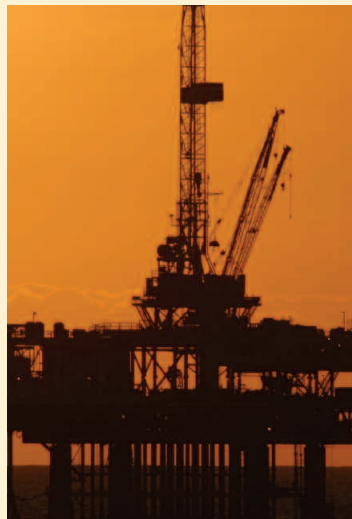



INDEX

ZEN INSULATED PRODUCTS FOR SAFE EARTHING SYSTEMS	105-110
HAZARDOUS AREA CABLE GLAND PRODUCTS (ATEX & IEC Ex)	111-134
MINING PRODUCTS FOR SURFACE & UNDERGROUND APPLICATIONS	135-148
NORTH AMERICAN SPECIFICATION CABLE CONNECTOR PRODUCTS	149-158
THREAD CONVERSION ADAPTORS AND REDUCERS	159-172
ACCESSORIES	173-175
TYPICAL INSTALLATION CONFIGURATIONS	176
MATERIAL AND THREAD SPECIFICATIONS	177
CABLE GLAND SELECTOR CHARTS	178-182



Cable Gland Type	Unarmoured Cables			Armoured Cables					
	Normal	Lead Sheathed	Conduit Connection	SWA	Braid	STA	Strip	PWA	Lead Sheathed
INDUSTRIAL CABLE GLANDS									
CABLE GLANDS FOR UNARMOURED CABLES									
A2	*								
A2RC	*		*						
SS2KGP	*								
SS2KGP PB		*							
A2DG	*								
A2 200	*								
CABLE GLANDS FOR ARMoured CABLES WITH SINGLE WIRE (S.W.A)									
BW				*					
BWL				*					
CW				*					
C2KGP				*	*	*	*	*	
E1W				*					
E1U				*	*	*	*	*	
E2W				*					*
E2U				*	*	*	*	*	*
CABLE GLANDS FOR ARMoured CABLES WITH ALUMINIUM SINGLE WIRE (A.W.A)									
CW ALUMINIUM				*					
E1W ALUMINIUM				*					
E1U ALUMINIUM				*	*	*	*	*	
E2W ALUMINIUM				*					*
E2U ALUMINIUM				*	*	*	*	*	*
CABLE GLANDS FOR ARMoured CABLES WITH WIRE BRAID ARMOUR (SWB, GSWB, CWB, TCWB OR BWB) OR SCREENED (BRAIDED) FLEXIBLE									
CX					*	*	*	*	
C2K GP				*	*	*	*	*	
CXT					*				
E1X					*	*	*	*	
E1U				*	*	*	*	*	
E2X					*	*	*	*	*
E2U				*	*	*	*	*	*
CABLE GLANDS FOR ARMoured CABLES WITH STEEL TAPE ARMOUR (S.T.A. / D.S.T.A.)									
CX					*	*	*	*	
C2K GP				*	*	*	*	*	
SS2KGP PB		*				*			
E1X					*	*	*	*	
E1U				*	*	*	*	*	
E2X					*	*	*	*	*
E2U				*	*	*	*	*	*



No Seal	Inner Seal	Outer Seal	Compound Barrier Seal	IP66	IP67	IP68	Deluge Proof	Industrial	Marine	Page Number
			*	*	*	*	*	*	*	82
			*	*	*	*	*	*	*	86
	*	*	*	*	*	*	*	*	*	84
	*	*	*	*	*	*	*	*	*	85
	*					*		*		93
	*							*		94
	*							*		77
	*							*		78
		*	*	*	*	*	*	*	*	80
		*	*	*	*	*	*	*	*	79
	*	*	*	*	*	*	*	*	*	89
	*	*	*	*	*	*	*	*	*	87
	*	*	*	*	*	*	*	*	*	90
	*	*	*	*	*	*	*	*	*	88
		*	*	*	*	*	*	*	*	80
	*	*	*	*	*	*	*	*	*	89
	*	*	*	*	*	*	*	*	*	87
	*	*	*	*	*	*	*	*	*	90
	*	*	*	*	*	*	*	*	*	88
		*	*	*	*	*	*	*	*	81
		*	*	*	*	*	*	*	*	79
		*	*	*	*	*	*	*	*	83
	*	*	*	*	*	*	*	*	*	91
	*	*	*	*	*	*	*	*	*	87
	*	*	*	*	*	*	*	*	*	92
	*	*	*	*	*	*	*	*	*	88
		*	*	*	*	*	*	*	*	81
		*	*	*	*	*	*	*	*	79
		*	*	*	*	*	*	*	*	85
	*	*	*	*	*	*	*	*	*	91
	*	*	*	*	*	*	*	*	*	87
	*	*	*	*	*	*	*	*	*	92
	*	*	*	*	*	*	*	*	*	88



Cable Gland Type	Unarmoured Cables			Armoured Cables					
	Normal	Lead Sheathed	Conduit Connection	SWA	Braid	STA	Strip	PWA	Lead Sheathed
HAZARDOUS AREA CABLE GLANDS									
CABLE GLANDS FOR UNARMOURED CABLES									
A2Pe	★								
A2F	★								
A2FRC	★		★						
SS2K	★								
SS2KPB		★							
PXSS2K	★								
PXRC	★		★						
CABLE GLANDS FOR ARMoured CABLES WITH SINGLE WIRE ARMOUR (S.W.A)									
CWe				★					
C2K				★	★	★	★	★	
T3CDS				★	★	★	★	★	
E1FW				★					
E1FU				★	★	★	★	★	
PX2K				★	★	★	★	★	
T3CDSPB				★	★	★	★	★	★
E2FW				★					★
E2FU				★	★	★	★	★	★
PX2KPB				★	★	★	★	★	★
CABLE GLANDS FOR ARMoured CABLES WITH WIRE BRAID ARMOUR (SWB, GSWB, CWB, TCWB OR BWB)									
CXe					★	★	★	★	
C2K				★	★	★	★	★	
D3CDS				★	★	★	★	★	
T3CDS				★	★	★	★	★	
E1FX					★	★	★	★	
E1FU				★	★	★	★	★	
PX2K				★	★	★	★	★	★
T3CDSPB				★	★	★	★	★	★
E2FX					★	★	★	★	★
E2FU				★	★	★	★	★	★
PX2KPB				★	★	★	★	★	★
CABLE GLANDS FOR ARMoured CABLES WITH STEEL TAPE ARMOUR (S.T.A. / D.S.T.A.)									
CXe					★	★	★	★	
C2K				★	★	★	★	★	
SS2KTA						★			
D3CDS				★	★	★	★	★	
T3CDS				★	★	★	★	★	
E1FX					★	★	★	★	
E1FU				★	★	★	★	★	
PX2K				★	★	★	★	★	★
T3CDSPB				★	★	★	★	★	★
E2FX					★	★	★	★	★
E2FU				★	★	★	★	★	★
PX2KPB				★	★	★	★	★	★
COMPOUND BARRIER CABLE GLANDS									
CABLE GLANDS FOR UNARMOURED CABLES									
PXSS2K	★								
PXRC	★		★						
CABLE GLANDS FOR ARMoured CABLES WITH WIRE BRAID, SINGLE WIRE, STRIP, PLIABLE WIRE & TAPE ARMOUR									
PX2K				★	★	★	★	★	
PX2KPB				★	★	★	★	★	★



	Inner Seal	Outer Seal	Compound Barrier Seal	IP66	IP67	IP68	Deluge Proof	Marine	Ex d IIC	Ex e II	Ex nR II	Ex tD A21 IP66	Ex d I	Ex e I	Page Number
		★		★						★					129
		★		★	★	★	★	★	★	★	★	★	★	★	115
		★		★					★	★		★			119
		★		★	★	★	★	★	★	★	★	★	★	★	116
		★		★	★	★	★	★	★	★	★	★			117
		★	★	★	★	★	★	★	★	★	★	★	★	★	133 + 156
		★	★	★				★	★	★		★			134
		★		★						★		★			121
		★		★	★	★	★	★		★		★			120
	★	★		★	★	★	★	★	★	★	★	★			113 + 154
	★	★		★					★	★	★	★	★	★	125
	★	★		★				★	★	★	★	★	★	★	123
		★	★	★	★	★	★		★	★	★	★	★	★	131
	★	★		★	★	★	★		★	★	★	★			114
	★	★		★					★	★	★	★			126
	★	★		★					★	★	★	★			124
		★	★	★	★	★	★		★	★	★	★			132
		★		★						★		★			122
		★		★	★	★	★	★		★		★			120
	★			★			★	★							153
	★	★		★	★	★	★	★	★	★	★	★			123
	★	★		★					★	★	★	★	★	★	127
	★	★		★					★	★	★	★	★	★	123
		★	★	★	★	★	★	★	★	★	★	★	★	★	131
	★	★		★	★	★	★		★	★	★	★			114
	★	★		★					★	★	★	★			128
	★	★		★					★	★	★	★			124
		★	★	★	★	★	★		★	★	★	★			132
		★		★						★		★			122
		★		★	★	★	★	★		★		★			120
		★		★	★	★	★	★		★		★			118
	★			★			★	★							153
	★	★		★	★	★	★	★	★	★	★	★			113 + 154
	★	★		★					★	★	★	★	★	★	127
	★	★		★					★	★	★	★	★	★	123
		★	★	★	★	★	★	★	★	★	★	★	★	★	131
	★	★		★	★	★	★		★	★	★	★			114
	★	★		★					★	★	★	★			128
	★	★		★					★	★	★	★			124
		★	★	★	★	★	★		★	★	★	★			132
		★	★	★	★	★	★	★	★	★	★	★	★	★	133 + 156
		★	★	★				★	★	★		★			134
		★	★	★	★	★	★	★	★	★	★	★	★	★	131
		★	★	★	★	★	★		★	★	★	★			132

TECHNICAL CONTENTS LOCATOR

Introduction to Cable Glands	11
Construction & Performance Standards	11-14
Crucial Cable Care	15-16
Overview of Cable Gland Construction Types	16-17
Industry Standard Cable Gland Designations	17-18

Generic Cable References	18-19
Fire Performance Cables	20
Halogen Free or Low Smoke & Fume Materials	20
CMP SOLO Low Smoke & Fume (LSF) Materials	21
Getting to Grips with Soft Bedded Cables	22

Ingress Protection Ratings	22-23
Deluge Protection Specification	24-25
Health & Safety at Work	25
Functional Safety	25
Electrical Safety in the Work Place	26
Wiring Regulations and Earthing Requirements	26-27
Safe Earthing Systems	27-28

CE Marking	29
Low Voltage Directive	29
EMC Directive	29-30
RoHS & WEEE Directives	31
Quality Management	31
Health, Safety & Environment	31

Cable Gland Selection Guidelines	32
How to Order	33

Introduction to Hazardous Areas (according to IEC)	34
Explosion Hazards	34
Principles of Protection	34
Risk Assessment Process for Hazardous Areas	35
Sources of Release	35
Grades of Release	35
Flammable Material Properties	35-36

TECHNICAL CONTENTS LOCATOR

Gas Groups	36
Sources of Ignition	36
Hazardous Area Equipment	37
Apparatus Surface Temperature Classification	37

Ambient Temperature	38
Classification of Hazardous Areas	38
Zone Definitions	39
Hazardous Area Forms of Protection	39-40
Combustible Dust Hazards	41-42
ATEX Directives	43-47

Non Electrical Equipment	47
Compliance with IEC Standards and European Normatives	48
Apparatus Marking	49
Purpose of Certification	50
IEC Ex Certification Scheme	50
Equipment Selection Process	51

Cable Glands for Hazardous Areas	51-52
Marking of Cable Glands for Hazardous Areas	53-54
Selection of Cables intended for use in Hazardous Areas	55
Compatibility of Equipment, Cable and Cable Gland	56
Selection Process for Hazardous Area Cable Glands according to IEC	57-60

Cold Flow	60-61
Risk Assessment Factors affecting cable gland selection	61
Installation	62
Inspection & Maintenance	63
Cable Glands for Mining Applications	63

Hazardous Locations according to NEC	63-64
Classification of Hazardous Locations, Class & Divisions	64-67
Equipment for Use in Class & Division Hazardous Locations	65-66
Equipment for Use in Class & Zone Hazardous Locations	66
Classification of Hazardous Locations, Class & Zones	66-67
NEC Flammable Material (Gas / Vapor / Dust) Definitions	66-67
UL standards incorporating IEC Zoning principals	68-69
Comparison between IEC / NEC-CEC Applications	69
North American Installation & Wiring Code Rules	69-70
Overview of Cables Permitted in Hazardous Locations	71-74



INTRODUCTION TO CABLE GLANDS

Cable Glands are mechanical cable entry devices, which can be constructed from metallic or non-metallic materials, and are used throughout all industries in conjunction with cable and wiring used in the electrical, instrumentation and automation systems.

Cable Glands may be used on all types of electrical power, control, instrumentation, data and telecommunications cables. They are used as a sealing and terminating device to ensure that the characteristics of the enclosure which the cable enters can be maintained adequately. The main functions of the cable gland are listed briefly as follows :-

Cable Glands may provide environmental protection by sealing on the outer cable sheath, excluding dust and moisture from the electrical or instrument enclosure.

Cable Glands may facilitate earth continuity in the case of armoured cables, when the cable gland has a metallic construction.

Cable Glands may provide a holding force on the cable to ensure adequate levels of cable pull out resistance.

Cable Glands may provide additional sealing on the part of the cable entering the enclosure, when a high degree of ingress protection is required.

Cable Glands may provide additional environmental sealing at the cable entry point, maintaining the ingress protection rating of the enclosure with the selection of applicable accessories dedicated to performing this function.

When used in hazardous areas they are required to maintain the level of protection of the equipment to which they are attached.

CONSTRUCTION & PERFORMANCE STANDARDS

National Cable Gland standards may exist that determine the construction and performance requirements for cable glands. During the formative years of the rapidly expanding power generation industry in the United Kingdom, the acute need for a common standard reference document that could address cable gland requirements was recognised, and from this GDCD 190 was created. The original goal was later met by the British Standard BS 4121, when the industry had developed further and with more sophistication. Latterly in the 1970's BS 4121 was superseded by BS 6121 with the introduction of the metric system of measurement across Europe.

Although it does not replace the full scope of the BS 6121 construction requirements, today there is a European Standard EN 50262, which offers manufacturers the opportunity of meeting its requirements by degrees of performance. It should be noted that whilst products that have been designed to comply with BS 6121 will

quite comfortably meet the requirements of EN 50262, it does not automatically follow that cable glands designed to EN 50262 would also be able to comply with the requirements of BS 6121. At the time of writing a new draft IEC standard for cable glands, IEC 62444 is being reviewed and will be published in due course.

It is the user's responsibility to ensure that the cable gland selected is of the correct size and type to suit the type of cable being terminated. The information provided below is intended to assist users in ensuring that the correct cable gland is selected. The European Cable Gland Standard EN 50262 : 1999 requires cable glands to be classified in accordance with their properties and performance. Users should therefore be aware that if they intend to select or specify cable gland products according to EN 50262 they must also stipulate clearly what classification from EN 50262 they require. Without such a clear definition the likelihood of the wrong product being obtained is increased.

For information purposes, here is a summary of the basic requirements of EN 50262

- 1) Material : Metallic, Non-metallic or a combination of both
- 2) Mechanical Properties :
 - i) For Cables without Armour - Anchorage Category (A or B)
 - ii) Impact Level
 - iii) For Cables with Armour – Retention Class (A or B)
- 3) Electrical Properties
- 4) Resistance to External Influences

These can be further explained as follows :-

- 1) Material : See Page 177 for CMP specification
- 2) Mechanical Properties :
 - i) For Cables without Armour - Anchorage Category (A or B)

Values taken from EN 50262 : 1999				Nearest CMP Cable Gland Size
Cable Diameter	Cable Retention (Newtons)	Cable Anchorage Type A (N)	Cable Anchorage Type B (N)	
Up to 4	5	-	-	-
> 4 to 8	10	30	75	16
> 8 to 11	15	42	120	20S
> 11 to 16	20	55	130	20
> 16 to 23	25	70	140	25
> 23 to 31	30	80	250	32
> 31 to 43	45	90	350	40
> 43 to 55	55	100	400	50
> 55	70	115	450	63

The actual Performance Capability for the CMP metallic cable gland range intended for unarmoured cables far exceeds the requirements of EN 50262 : 1999 Category B

ii) Impact Level

Category	1	2	3	4	5	6	7	8
Newtons (N)	2.0	2.0	2.0	2.0	10.0	10.0	10.0	20.0
Weight (KG)	0.2	0.2	0.2	0.2	1.0	1.0	1.0	2.0
Energy (J)	0.2	0.5	1.0	2.0	4.0	7.0	7.0	20.0
Height (M)	0.1	0.3	0.5	1.0	0.4	0.7	0.7	1.0

Please note that all CMP cable gland types meet the 20J (20Nm) impact resistance test (level 8).

iii) For Cables with Armour – Retention Class (A or B)

EN 50262 : 1999 Values			Nearest CMP Cable Gland Size
Cable Diameter	Cable Retention Class A (N)	Cable Retention Class B (N)	
> 4 to 8	75	640	16
> 8 to 11	120	880	20S
> 11 to 16	130	1280	20
> 16 to 23	140	1840	25
> 23 to 31	250	2480	32
> 31 to 43	350	3440	40
> 43 to 55	400	4400	50
> 55	450	5600	63

The actual Performance Capability for the CMP metallic cable gland range intended for armoured cables far exceeds the requirements of EN 50262 : 1999 Category A & B

3) Electrical Properties - Protective Connection to Earth (Category A, B or C).

Cable Diameter	rms current (kA)			Nearest CMP Cable Gland Size (Metric)
	Category A – Cable Gland only	Category B – with an Earth Tag attached	Category C - with a heavy duty Integral Earth Lug	
> 4 to 8	0.5	3.1	10.0	16
> 8 to 11	0.5	3.1	13.1	20S
> 11 to 16	0.5	3.1	13.1	20
> 16 to 23	0.5	4.0	13.1	25
> 23 to 31	0.5	5.4	13.1	32
> 31 to 43	1.8	7.2	43.0	40
> 43 to 55	2.3	10.4	43.0	50
> 55	2.8	10.4	43.0	63

(See also the technical information detailed on pages 27 & 28.)

Note: Category A, is the minimum requirement which may apply in cases where the cable armouring (other than steel wire) is the limiting factor & where the cable gland is screwed into a threaded hole in the metallic equipment enclosure.

Category B, is the medium requirement which may apply in cases where steel wire / metallic sheathed armoured cable is used and the system includes a high sensitivity method of secondary protection against fault currents and where earth tags are used with the cable gland.

Category C, is the highest requirement, which may apply in cases where steel wire / metallic sheathed armoured cable is used and the system relies on a low sensitivity method of secondary protection against fault currents and where integral earth lugs (e.g. CMP CIEL) are incorporated into the cable gland. (see page 28 and 100 for further details).

4) Resistance to external influences – i) Ingress Protection Minimum of IP54, ii) Salt & sulphur laden atmospheres.

In respect of 4) i. above CMP Products can confirm that its minimum Ingress Protection rating is IP 66 to IEC 60529. Please see individual cable gland catalogue pages for further information.

To meet the requirements of 4) ii. above CMP would recommend electroless nickel plating when cable glands are required to be installed in salt laden atmospheres. In addition stainless steel or copper free aluminium cable glands are recommended for use in sulphur atmospheres and stainless steel with a minimum grade 316 for use in H2S atmospheres.

For comparison purposes only, set out below are some of the key differences between BS6121:1989 and EN50262:1999.

Test	BS 6121	EN 50262
Cable Gland Type Designation	Specified as per Cable Sealing Concept	Not Specified
Cable Gland Construction	Across Flats & Lengths Specified for each Cable Gland Size	Not Specified, Each manufacturer can be different
Cable Acceptance	Specified for both Inner and Outer Sheaths for each Cable Gland Size	Not Specified, Manufacturer must state cable acceptance range in its literature
Ingress Protection Rating	Must be Minimum of IP66	Must be Minimum of IP54
Armoured Cable Pull Out	Specified but varies with Cable Gland Size, Minimum 2.7kN to Maximum 8.83kN	Varies with Cable Diameter not Cable Gland Size, Minimum 75 Newtons to Maximum 450 Newtons
Unarmoured Cable Pull Out	Specified but varies with Cable Gland Size, Minimum 2.7kN to Maximum 8.83kN	Varies with Cable Diameter not Cable Gland Size, Minimum 4 Newtons to Maximum 70 Newtons
Twist Test	Not Specified	Torque applied which varies with Cable Size, Minimum 0.1 Newtons to Maximum 1.2 Newtons
Impact Level	Not Specified (Due to Torque & Construction being so detailed)	8 Categories Specified, Minimum 0.2J to Maximum 20J
Proof Torque	Specified but varies with Cable Gland Size, Minimum 2.7kN to Maximum 8.83kN	50% above the manufacturers stated Installation Torque
Electrical Resistance Cable To Gland	Two Tests, Not more than 10% difference Is allowed.	Specified 0.1 Ohm allowed
Earth Fault Rating	Not Specified due to high cable pull out resistance	Specified Categories A, B, or C. Minnum 1.0 kA to Maximum 43.0 kA
Temperature Range	Not Specified, Dependent upon the Seal Material	Specified minimum range of -25° C to +65° C
Seal Compression Test	After Conditioning, No more than 25% variation	Not Specified
Seal Ageing / Hardness Test	After Conditioning, No more than 15% variation	Not Specified

CRUCIAL CABLE CARE

When terminating cables and wires during the process of installation of electrical equipment this should be done by qualified and competent personnel in line with good engineering practice, observing safe electrical practices. It is also important that the correct cable entry device or cable gland is selected to suit the cable being used. For instances using normal unarmoured cables, the cable would usually be fed through a cable entry device that has a sealing ring activated onto the cable outer sheath. The choice of cable glands to suit this unarmoured cable may need to take into account any vulnerability of the cable, which may be especially critical if the cable is an instrument cable. Two factors which could affect the long term cable performance are the type and design of the cable gland sealing function, and the possibility of this being inadvertently, or otherwise, over tightened onto the cable sheath.

In some applications it may be necessary to provide some mechanical protection to prevent the cables from being damaged or completely severed by accidental encroachment of machinery or

other major impact. This mechanical protection may be provided in the shape of a metallic conduit that can house individual insulated cable conductors or a normal unarmoured sheathed cable. Alternatively a metallic sheath or armour included in the cable construction during its manufacturing process may be used.

When cables with a protective metallic sheath or armour are chosen, these may be constructed with or without an extruded inner bedding, underneath the layer of armouring. In some cases this extruded bedding may be substituted by a polymeric covering or tube that contains the insulated conductors.

Cable glands for armoured cables, with a single outer seal should be selected for cables without an inner bedding or covering under the armour. Cable glands for armoured cables, with a double, inner & outer, seal configuration would normally be selected for cables with an inner bedding or covering under the armour.

Overview of Different Seal Types

In general there are five different types of sealing methods used on the cable inner bedding, which are:-

- i. Compression Seal
- ii. Displacement Seal
- iii. Diaphragm Seal
- iv. Compensating Displacement Seal (CDS) System
- v. Compound Barrier Seal.

These are better described as follows :-

i. Compression Seal (Sealing Ring)

The Compression Seal is an elastomeric sealing ring that has a V groove or weak back in its design that is intended to be closed in order to create a downward seal on the cable inner bedding, when the same compressive force is equally applied to both sides of the seal.

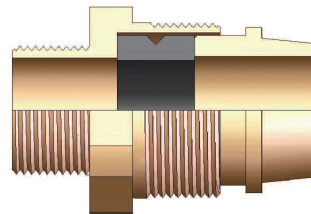

i. Compression Seal

ii. Displacement Seal (Sealing Ring)

The Displacement Seal does not employ a weak back design. Instead the Displacement Seal is gradually pushed down a taper until it makes an effective seal on the cable.

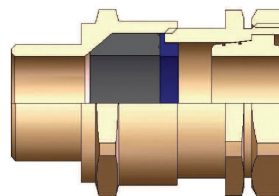

ii. Displacement Seal

iii. Diaphragm Seal (Sealing Ring)

The Diaphragm Seal comprises of a flexible elastomeric membrane that is usually attached to the armour cone, and it is designed to fit snugly after stretching over the cable inner bedding. This is intended to make no impression on the cable inner bedding.

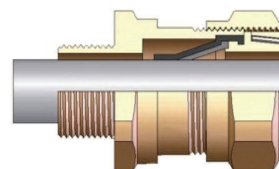

iii. Diaphragm Seal

iv. Compensating Displacement Seal (CDS) System (Sealing Ring)

The Compensating Displacement Seal system utilises the principal of the Displacement Seal but with the addition of a compensator that limits or controls the force applied to the cable inner bedding.

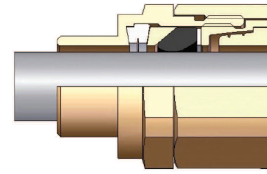

iv. Compensating Displacement

v. Compound Barrier Seal (Epoxy Resin Compound)

The compound barrier seal is made on site by the technician completing the installation and is used primarily in hazardous areas where the inner cable bedding must be removed and a hard setting resin barrier seal that has been specially tested for use in potentially explosive atmospheres is applied around the conductors.

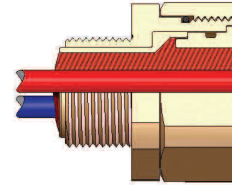

v. Sealing Compound Flameproof Barrier

OVERVIEW OF CABLE GLAND CONSTRUCTION TYPES

When appraising products for an application the particular type of sealing ring employed within the cable gland design may be the deciding factor in terms of cable gland selection.

It should be recognised that cables are produced in various parts of the world to numerous different national and international standards, and the physical characteristics of one cable made by a certain manufacturer may differ considerably from another maker’s product, even when the two cables have the same theoretical electrical parameters or ratings.

Close attention should be paid to this selection process taking into account the cable construction and any vulnerability it may present. The reason for this is because some cable gland constructions are more compatible with certain cable types than others, and this is often due to the sealing method incorporated.

Cable Gland Construction utilising Compression Seal

A typical cable gland utilising a compression seal within its design, as the example shown below, has been known to cause cable damage due to over tightening as it has no inbuilt functionality to prevent the user from over tightening. More to the point is that when this type of cable gland is installed, the action of tightening the inner sealing ring is combined with the termination of the metallic cable armour. This leads the user to feel the need to tighten the assembly as far as he can to ensure that he has a good reliable earth continuity path, and often the cable inner bedding suffers as a result. In effect there is no real control over how tight the inner sealing ring is applied to the cable inner bedding, when the tightening of the cable gland body performs two actions in one step.

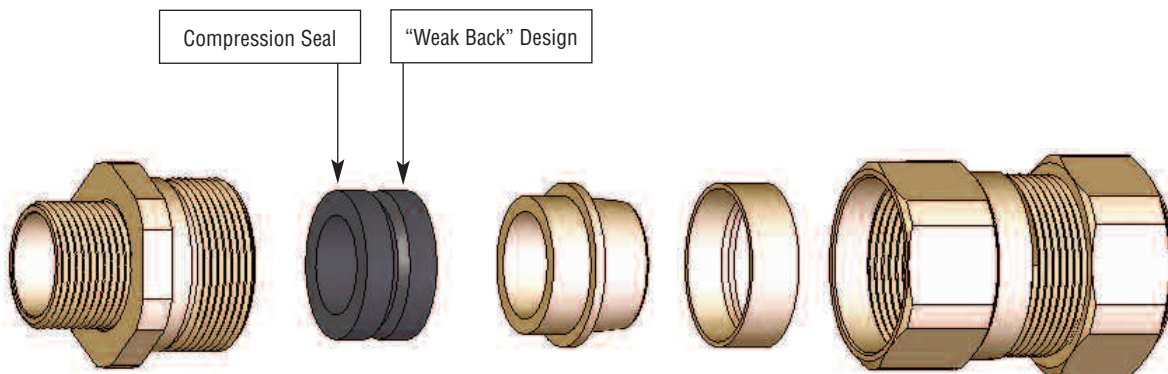

The sealing on the cable inner bedding and the armour termination are effected in one simultaneous action, which typically involves the armour cone being tightened until it reaches a defined mechanical stop. This can lead to the compression seal being over compressed, especially on the larger cable diameters for each cable gland size.

This can be loosely described as “over tightening”, and is a common problem with certain cable gland types.

It should be noted that none of the cable glands supplied by CMP Products utilise compression seals on the cable inner bedding.

Cable Gland Construction utilising Displacement Seal

This type of seal is usually employed in a cable gland that utilises a 3 stage 'Step by Step' sequential make off, where the tightening of the armour termination is separated from the activation of the inner seal. This enables the effectiveness of the seal on the cable inner bedding to be tested before the armour is terminated. This means that unlike other designs the user is able to determine that the engagement of the seal on the cable inner bedding is not too light and not too heavy, affording some level of control over the installation.

It can be noted that this displacement seal arrangement is the standard method of sealing on the cable inner bedding adopted by CMP Products.

Separate Tightening Actions

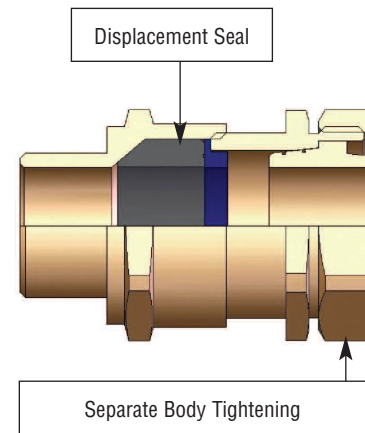

Cable Gland Construction utilising Compensating Displacement Seal (CDS) System

The Compensating Displacement Seal system is designed to allow users to fully tighten the cable gland components together every time, without damaging the cable. The use of an internal compensator enables the CDS arrangement to be fully tightened regardless of the cable diameter. This unique approach offers a solution that allows the installation personnel to carry out their objectives to schedule without the likelihood of re-work potentially arising from over tightening.

The unique Compensating Displacement Seal (CDS) system is a design patented by CMP Products.

Compensating Displacement Seal System

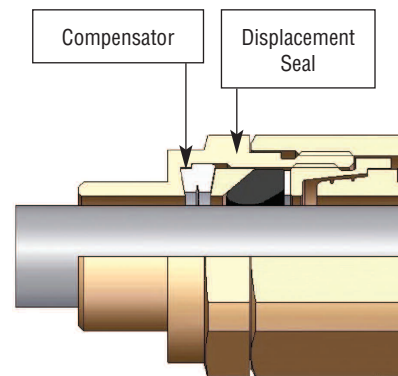

Industry Standard Cable Gland Designations

Cable Glands may be designed, tested and manufactured to various standards around the world, but since CMP Products is a long established UK based manufacturer, it just so happens that part of its history includes close participation in the development of British Standards for these products.

In fact BS 6121 also established the industry standard cable gland type designations that still prevail today for simple cable gland identification. It should be noted however that the type designation for a given cable gland product does not determine the precise method of sealing adopted.

The British Standard BS 6121, and its predecessor BS 4121, have more than 30 years of exposure in meeting real life industry situations, not just in the UK but also around the world.

BS 6121 Definitions

Below are tables composed from data included in **BS 6121 : Part 1 : 1989** :-

Type	Definition
A1	For unarmoured cable with an elastomeric or plastic outer sheath, with sealing function between the cable sheath and the sealing ring of the cable gland.
A2	As type A1, but with seal protection degree IP66
A3	As type A1, but with an electrical bond for the metallic inner screen

Table A: Cable gland type designations for unarmoured cables

Code	Definition
B	No Seal
C	Single Outer Seal
D	Single Inner Seal
E	Double (Inner & Outer) Seal suffix '1' = Normal suffix '2' = Lead Sheathed

Table B: Cable gland type designations for armoured cables

Designation of cable armouring	
T	Pliable Wire Armour
W	Single Wire Armour
X	Braid
Y	Strip Armour
Z	Tape Armour

Table C: Cable type designations

Type	Definition
A2	Cable Gland for unarmoured cable with outer seal
BW	Cable Gland for SWA cable without seal
CW	Single Seal Cable Gland for SWA cable
E1W	Double Seal Cable Gland for SWA cable
CX	Single Seal Cable Gland for braided cable
E1X	Double Seal Cable Gland for braided cable

Table D: Typical Cable Gland type designations derived from tables A to C

GENERIC CABLE REFERENCES

The following key and tables set out the regular cable identifications derived from the traditional British Standards, the terminology of abbreviations that is associated with these cables, and also where these cables may typically be used in everyday applications.

Key to Armoured Cable Type Designations as Defined in BS 6121 : Part 1 : 1989

[W] - Cables with Single Wire Armour (SWA) – used extensively in onshore plant both above ground and directly buried in the ground, and is probably the most common type of armoured cable used in the world. This cable type is produced mainly with steel wires, but is also supplied with aluminium wire armour, especially when the cable is either a single core cable or has aluminium conductors.

[T] - Cables with Pliable Wire Armour (PWA) – used extensively in the mining and quarrying industry particularly in underground deep coal mines, as it offers high level of mechanical protection but added flexibility compared with SWA.

[X] - Cable with Braid Armour (e.g. GSWB) – used onshore and offshore and comes in a wide variety of types, including galvanised steel wire, tinned copper wire, bronze wire, and is the standard for marine shipboard cables, and the offshore oil and gas industry around the world, because of its high level of flexibility.

[Y] - Cable with Strip Armour (e.g. ASA) – used onshore, offering heavy duty service, high level of mechanical protection but is probably the least common type of armoured cable. This cable type is often produced with aluminium strip armour but is also supplied using steel strip armour.

[Z] - Cable with Tape Armour (e.g. STA) – primarily used onshore, often referred to as DSTA, and the tape armour is manufactured in either steel (STA) or aluminium (ATA). The use of Tape Armour can mean a lighter, leaner and smaller diameter alternative to SWA, but may not be available from all cable manufacturers.

Cables that can be supplied either equipped or not equipped with armour types listed above may be produced to the following typical cable standards :-

BS 5308, BS 5467, BS 6004, BS 6007, BS 6116, BS 6346, BS 6480, BS 6500, BS 6622, BS 6724, BS 6883, IEC 60092, IEC 60502.

Abbreviations and Applications

Mainly Used Onshore	Cable Definition	Abbreviation(s)			Offshore	Onshore
	Single Wire Armour (or Steel Wire Armour)	SWA			NO	YES
	Single Wire Armour, Lead Sheathed (or Steel Wire Armour, Lead Sheathed)	SWA, LC	LC/SWA	LS/SWA	NO	YES
	Steel Tape Armour	(D)STA			NO	YES
	Steel Tape Armour, Lead Sheathed	(D)STA, LC	LC/(D)STA	LS/(D)STA	NO	YES
	Aluminium Wire Armour	AWA			NO	YES
	Aluminium Wire Armour, Lead Sheathed	AWA, LC	LC/AWA	LS/AWA	NO	YES
	Aluminium Strip Armour	ASA			NO	YES
	Aluminium Strip Armour, Lead Sheathed	ASA, LC	LC/ASA	LS/ASA	NO	YES
	Flat Steel Wire	NY KGby			NO	YES
	Flat Steel Wire, Lead Sheathed	NY KGby			NO	YES
Lead Sheathed	NY KY			NO	YES	

Mainly Used Offshore	Steel Wire Braid	SWB			YES	YES
	Galvanised Steel Wire Braid	GSWB			YES	YES
	Copper Wire Braid	CWB			YES	YES
	Tinned Copper Wire Braid	TCWB			YES	YES
	Bronze Wire Braid	BWB			YES	YES
	Phosphor Bronze Wire Braid	PBWB			YES	YES
Rarely / Never Used Offshore	Steel Wire Braid, Lead Sheathed	SWB, LC	LC/SWB	LS/SWB	NO	YES
	Galvanised Steel Wire Braid, Lead Sheathed	GSWB, LC	LC/GSWB	LS/GSWB	NO	YES
	Copper Wire Braid, Lead Sheathed	CWB, LC	LC/CWB	LS/CWB	NO	YES
	Tinned Copper Wire Braid, Lead Sheathed	TCWB, LC	LC/TCWB	LS/TCWB	NO	YES
	Bronze Wire Braid, Lead Sheathed	BWB, LC	LC/BWB	LS/BWB	NO	YES
	Phosphor Bronze Wire Braid, Lead Sheathed	PBWB, LC	LC/PBWB	LS/PBWB	NO	YES

FIRE PERFORMANCE CABLES

The development of electric cables for fire situations has meant that Fire Performance cables have become an almost everyday requirement in the construction industry globally, but the general subject of fire performance cables can be a complex one. The need for cables to continue to perform in the event of a fire is more prevalent today than ever before, and in the case of public buildings the need to reduce the toxicity content in the materials used to produce cables carries equal importance.

The dangers of fire would include the safety of people and the continuous functioning of electrical circuits required to maintain safety. In the case of electric cables their construction may need to

address some or all of the following; fire survival, fire resistance, fire propagation, flame retardancy, smoke emission and toxicity.

Even if the electrical circuit was not the cause of a fire, the electric cable may very well be engulfed in a fire that has started elsewhere. Consequently the compounds that the cable is produced from should not contribute to the fire, help spread it, or emit gases during combustion that could harm people or damage equipment. Another aspect to consider is that the density of smoke generated in the event of a fire should not be sufficient to obscure emergency exit signs. Most cable standards therefore include some kind of fire performance and testing requirements, but there are many in existence.

Fire Test Standards for Cables

Here are a selection of standards used in relation to fire tests for cables :-

- BS 6387** : Performance requirements for cables required to maintain circuit integrity under fire conditions
- EN 50266** : Common test methods for cables under fire conditions - Test for vertical flame spread of vertically-mounted bunched wires or cables
- EN 50267** : Common test methods for cables under fire conditions - Tests on gases evolved during combustion of materials from cables
- EN 50200** : Method of test for resistance to fire of unprotected small cables for use in emergency circuits
- BS 8434-1** : Methods of test for assessment of the fire integrity of electric cables. Test for unprotected small cables for use in emergency circuits. (EN 50200 with addition of water spray)
- BS 8434-2** : Methods of test for assessment of the fire integrity of electric cables. Test for unprotected small cables for use in emergency circuits. (EN 50200 with a 930°C flame and with water spray)
- IEC 60331** : Tests for electric cables under fire conditions
- IEC 60332** : Tests on electric and optical fibre cables under fire conditions
- IEC 60754** : Test on gases evolved during combustion of materials from cables
- IEC 61034** : Measurement of smoke density of cables burning under defined conditions.

HALOGEN FREE OR LOW SMOKE & FUME MATERIALS

As outlined in the previous subject certain cable types are designed with the performance capability of surviving fire conditions for a specified period, whilst other cable types may be manufactured using polymer compounds that generate lower smoke and fume emissions. In such cases the cables may be identified as being Halogen Free, Low Smoke & Fume (LSF), Low Smoke Zero Halogen (LSZH), or Zero Halogen Low Smoke (ZHLS).

These compare favourably with traditional electric cables that were likely to generate noxious emissions of gases in fire situations, that may have been manufactured and installed many years ago, prior to the introduction of the most recent cable standards and the development of new environmentally friendly compounds.

It is equally important that the materials used in the manufacture of cable management products, including cable cleats, cable clamps cable glands, their seals, and any shrouds that are required to be fitted, can offer the same high level of compliance in the way of lower smoke and fume emissions.

Some cables, but not all, that bear Low Smoke & Fume and /or Zero Halogen characteristics may have an inner cable bedding that is extruded from a compound which has not been fully cured during the manufacturing process. This is often referred to as a soft bedding, and this itself brings an additional factor to consider when selecting appropriate cable sealing glands to suit cables having this characteristic.

CMP SOLO LOW SMOKE & FUME (LSF) MATERIALS

CMP Products has been instrumental in the field of providing cable management solutions produced from materials that are designed to reduce the risk of toxic emissions and smoke inhalation. These solutions or products include cable cleats, cable clamps, cable glands, and their accessories, all of which are required to meet the same exacting standards as is applied to electric cables. In the past cable gland seals were generally manufactured from Neoprene materials (e.g. Polychloroprene or Chloroprene CR), although there are varying grades and types of Neoprene materials on the market, and shrouds were most commonly produced from PVC (Polyvinyl chloride). At the time when these materials were first selected for certain applications they may well have been chosen because they were the best or the most readily available material source to suit the intended use. Now however with the benefit of hindsight, and with a greater emphasis on environmentally friendly substances, taking into account the health & safety requirements for people occupying public buildings or being in public places, the commonly used materials of the past have become less attractive for use in cable management products.

Now, with the availability of a new generation of improved material compounds and formulas it has been possible to draw comparisons identifying that Neoprene and PVC would no longer be the first choice when it comes to smoke and fume emissions. With its SOLO LSF brand of Low Smoke & Fume elastomeric compound formula, CMP Products has helped spearhead the drive in the industry, by specification, to ensure a higher degree of protection in terms of reduced levels of noxious fumes and toxic emissions generated from cable related products in the event of a fire.

CMP Products has had the material used in the CMP LSF Seals and Shrouds independently 3rd Party tested to EN 50267-2-1, the test standard applied to cables to determine the amount of halogen acid gas evolved during combustion of materials. The objective of the test is to identify whether the halogen acid gas evolved from the material is within the maximum 5mg/g permitted by the standard. CMP Products declares that the CMP SOLO LSF material emits less than 5mg/g acid gas, which satisfies the requirements of this EN 50267-2-1, and the results of the Fire Laboratory tests confirm that material is classified as "Halogen Free".

For clarification, the EN 50267-2-1 standard reveals that :-

Materials found to emit <150 mg/g (<15%) halogen acid gas during combustion are classed as Low Halogen

Materials found to emit <5 mg/g (<0.5%) halogen acid gas during combustion are classed as Halogen Free

For further information please refer to EN 50267-2-1 : 1999 - Common Test Methods for Cables Under Fire Conditions - Tests on Gases Evolved During Combustion of Materials From Cables - Part 2-1: Procedures - Determination of the Amount of Halogen Acid Gas

The CMP SOLO products initially witnessed significant demand during the new construction of public buildings such as airports, tunnels, MRT systems, office blocks, shopping centres, sports stadia, libraries etc. but the maturing market demand has also extended to wider areas other than the above.

One particularly significant application has been the use of CMP SOLO LSF range within the underground railway system in the UK's capital city. Throughout London Underground Limited (LUL) there is an overriding priority for the safety of passengers. One of the greatest dangers in any deep bore metro system is the difficulty of evacuating customers and staff in the event of a major fire. It has therefore been LUL's policy for many years to control the fire performance of materials used underground through its own requirements in addition to those required by legislation. Although this is not a new situation, LUL operates a process, within its fire safety department, that evaluates the properties of compounds used in cable and cable related products against specified materials fire performance requirements. CMP Products has extensive experience of meeting the conditions of these tests and supplying various products to such a safety critical area.

One of the advantages of using new polymer compound formulas for the manufacture of cable gland seals and shrouds etc. is that they can also offer additional benefits in the way of performance in several key areas, such as :-

- Increased Resistance to Ozone
- Improved UV Resistance
- Improved Oil Resistance
- Increased Maximum Operating Temperatures
- Improved Minimum Operating Temperatures
- Reduced Shore Hardness

GETTING TO GRIPS WITH SOFT BEDDED CABLES

The increasing popularity of fire resistant and flame retardant cables particularly for safety focussed application such as oil & gas installations, refineries and chemical plants has led to a proliferation of what are commonly described as soft bedded cables. A general description of a soft-bedded cable is one which employs materials, which exhibit, 'significant cold flow' characteristics, i.e. thermoplastic materials, which flow when subject to pressure at ambient temperature. This bedding is the cable inner bedding, which in the case of an armoured cable, is the part of the cable which enters the equipment.

Particular care should generally be taken when installing this type of cable, so as to avoid cable damage due to over tightening of cable gland seals on the cable inner bedding. The selection of suitable cable glands to complement this type of cable construction is vital, as the traditional compression seal cable gland is most likely to cause excessive pressure on the part of the cable which is most vulnerable, leading to cable damage and potential long term di-electric problems.

An increased level of attention in this area may be required for installations in hazardous areas for obvious reasons which are subsequently explained on page 60 of this catalogue.

A common method of addressing this problem is to use a displacement seal, whereby the seal is gradually displaced as the cable gland is tightened, virtually eliminating any damage to cable bedding. The purpose of this design enables the user to control the level of displacement of the seal, ensuring a functional and more importantly, safe, seal is achieved without exerting any undue pressure onto the cable. An example of a cable gland utilising a displacement seal on the cable inner bedding is illustrated below. The other important fact to note is that this also utilises a separate tightening action for the inner seal and the armour termination compartment, which is the differentiating feature compared with other cable gland designs.

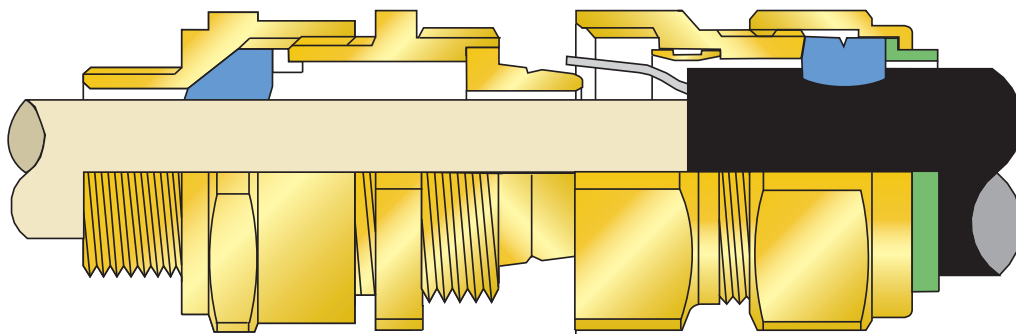

Naturally, many factors influence the final method of installation including, environment, ambient temperatures, and the specific construction of the cable being used. CMP Products are always

willing to provide an expert assessment of a given application, drawing on many years experience of installation procedures, providing assurances that a safe solution is achieved every time.

INGRESS PROTECTION RATINGS









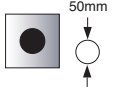

In the construction industry generally, a significant volume of industrial electrical installations require a high level of ingress protection to be afforded from the equipment selected for the installation and the integrity of the installed apparatus.

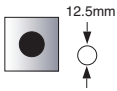
Like other electrical equipment enclosures that are required to have a verified Ingress Protection rating, cable glands are also required to be tested to recognised standard test methods for Ingress Protection, as per the example table overleaf. The range of CMP cable glands have been 3rd party independently tested in order to validate their Ingress Protection ratings, or I.P. ratings, in accordance with the requirements of EN60529 (IEC 60529). Some of the CMP cable gland

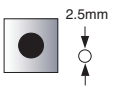
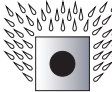
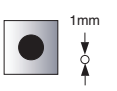
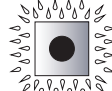
types have been tested to IP66, whilst other types have been tested to IP66, IP67 & IP68, to a depth of 10 metres*. Ingress Protection should not be confused with Deluge Protection (i.e. the DTS 01 : 91 Deluge Test) which lays down a set of specific standard tests that are different from those in the IEC 60529 standard. It should be noted that none of the I.P. rating values taken from EN 60529 or IEC 60529 are equivalent to the Deluge Test Specification DTS 01 : 91.

Further information on the subject of Deluge Protection can be reviewed on page 24 overleaf.

Ingress Protection Matrix

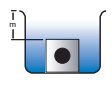
First Digit	Protection against Solid Foreign Objects and Access to Hazardous Parts			Second Digit	Protection against Liquids	
	Illustration	Method	Explanation		Illustration	Method
0	-	Non-protected	Non-protected	0	-	Non-protected
1		Protected against solid foreign objects of 50mm diameter and greater	Protected against access to hazardous parts with the back of a hand	1		Protected against drops of water falling vertically
2		Protected against solid foreign objects of 12.5mm diameter and greater	Protected against access to hazardous parts with a finger	2		Protected against drops of water falling at up to 15° from the vertical
3		Protected against solid foreign objects of 2.5mm diameter and greater	Protected against access to hazardous parts with a tool	3		Protected against spraying water at up to 60° from the vertical
4		Protected against solid foreign objects of 1.0mm diameter and greater	Protected against access to hazardous parts with a wire	4		Protected against splashing water from all directions
5		Dust-protected	Protected against access to hazardous parts with a wire	5		Protected against jet of water from all directions
6		Dust-tight	Protected against access to hazardous parts with a wire	6		Protected against jet of water of similar force to heavy seas
				7		Protected against the effects of immersion
				8		Protected against prolonged effects of immersion under pressure to a specified depth

* Please refer to appropriate catalogue pages for specific Ingress Protection ratings according to their design and construction.

In addition to the Ingress Protection tests carried out as standard on the CMP range of Cable Glands, selected products have additionally been tested to meet the requirements of NEMA 4X in accordance with North American standards. The following table is provided for comparison purposes between typical NEMA and IEC 60529 ratings.

ENVIRONMENTAL RATINGS			
NEMA RATING	IEC 60529 RATING	SOLIDS	WATER
1	IP23	Objects > 12.5 mm	Spraying
2	IP30	Objects > 2.5 mm	Spraying
3	IP64	Dust-Tight	Splashing
3R	IP32	Objects > 2.5 mm	Drips at 15°
3S	IP64	Dust-Tight	Splashing
4	P65-66	Dust-Tight	Jet to Power Jet
4X	IP66	Dust-Tight	Power Jets
6	IP67	Dust-Tight	Temporary Immersion
6P	IP68	Dust-Tight	Prolonged Immersion
12	IP55	Dust-Protection	Jets
13	IP65	Dust-Tight	Jets

Note: NEMA Ratings can be converted to IEC IP ratings but IEC IP Ratings CANNOT be converted to NEMA Ratings.

DELUGE PROTECTION SPECIFICATION DTS 01:91

Offshore platforms are subject to routine testing of their emergency deluge systems with up to 30,000 litres of water per minute being unloaded in the modules making up the process areas. To keep pace with this development, equipment manufacturers have had to have their products tested for such conditions.

The DTS01 Test Specification was developed by Shell UK in conjunction with ERA Technology, based in Leatherhead, Surrey. Since its inception in 1991 it has become widely accepted by all major offshore operating companies as the standard to meet in respect of deluge protection.

Electrical equipment on offshore installations may be located in areas which are equipped with the emergency deluge facilities. Exposure of such equipment must not lead to water ingress in quantities which could cause the equipment to become a potential source of ignition when exposed to a flammable atmosphere.

The introduction of DTS 01 created a standard method of tests to be carried out on electrical equipment, components, devices and motors to simulate their exposure to realistic water deluge conditions and establish their potential hazard. This was considered to far outreach any of the Ingress Protection tests that were already performed under the IEC 60529 standard, as longer term exposure to the typical marine and offshore environment often brought with it more onerous conditions than those anticipated by IEC 60529.

The Deluge Test utilises a salt water solution controlled at pre-determined temperatures and this is applied using medium velocity nozzles at a pressure in the range of 3.5 to 4.5 bar. To make the test most realistic an additional pre-conditioning is applied to the samples to be tested. This pre-conditioning can optionally consist of either exposure to vibration or thermal ageing depending upon the nature of the equipment under test. The purpose of this pre-conditioning is to simulate accelerated ageing of the seals used in the equipment prior to the tests being conducted, which is considered to be equivalent to 20 years of service at normal operating temperatures.

With cable glands it is more logical to have their sealing rings subjected to the rapid thermal ageing rather than vibration exposure tests. The cable glands and sealing rings are conditioned in a humidity chamber for 14 days, at 95°C and a relative humidity of 90%. They are then further subject to a temperature of 100°C for 14 days, prior to the deluge test commencing. Then they are installed into equipment which is heated to simulate its operating temperature at a typical ambient, and are subjected to a cold water deluge spray, creating an internal vacuum, which would draw water through the cable glands into the equipment if the deluge seal did not perform.

At CMP, the ageing of cable gland seals, taking into account such things as the heat cycling effects of electrical apparatus, is seen as having a major bearing on proving true long term protection against deluge conditions. Significantly, CMP has had the confidence in

having a number of its innovative Cable Glands, including the T3CDS range tested to this onerous requirement. Under the close third party scrutiny, and the rapid ageing specification described above, CMP has been able to demonstrate the durability of its products in these conditions, whereas not all cable gland manufacturers have been able to meet the exacting demands of this criterion.

One of the features of a true deluge proof cable gland for armoured, or braided, cables which makes it stand out above other standard cable glands is the inclusion of a deluge seal. This deluge seal is applied in the joint where the cable gland body terminates the cable braid armour and it is included for protection against a specific and costly problem that has been experienced in offshore environments around the world. Prior to the introduction of high powered emergency deluge systems the problem that was experienced in the most hostile offshore situations was frequent yet often premature cable braid armour corrosion. This corrosion was occurring due to the ingress of water through the armour termination compartment of the cable gland, even when a cable gland had passed an Ingress Protection test of IP66 or higher. Following investigation, the evidence pointed to the fact that during energising and de-energising of the electrical equipment the heat cycling effects were causing positive and negative changes in the internal pressure of the equipment. This change in pressure was in turn causing water to work its way around the threaded joints in the cable gland via a capillary action that meant the cable braid would in time be contaminated by salt water. This often led to rapid deterioration and even corrosive breakdown of the cable braid that was commonly made of Galvanised Steel Wire. In the experience of major oil and gas operating companies, this known problem was first discovered as a serious problem when earth continuity checks highlighted the fact that there was no continuity through the cable at all.

Tackling this serious problem and also going one step further in addressing the requirements of the Deluge Test at the same time, when potentially more frequent exposure to salt water conditions would result, CMP Products was the first manufacturer to introduce a Deluge Proof cable gland design. This design of course featured a positive sealing function between the cable gland components that make up the armour termination joint, like the example shown below. It should be recognised that whilst it may be possible to obtain an IP67 or IP68 rating with a cable gland that does not include a deluge seal feature, it is highly unlikely that such a product would pass the conditions of the DTS 01 : 91 Deluge Test and realistically ensure long term cable armour preservation in offshore or marine installations.

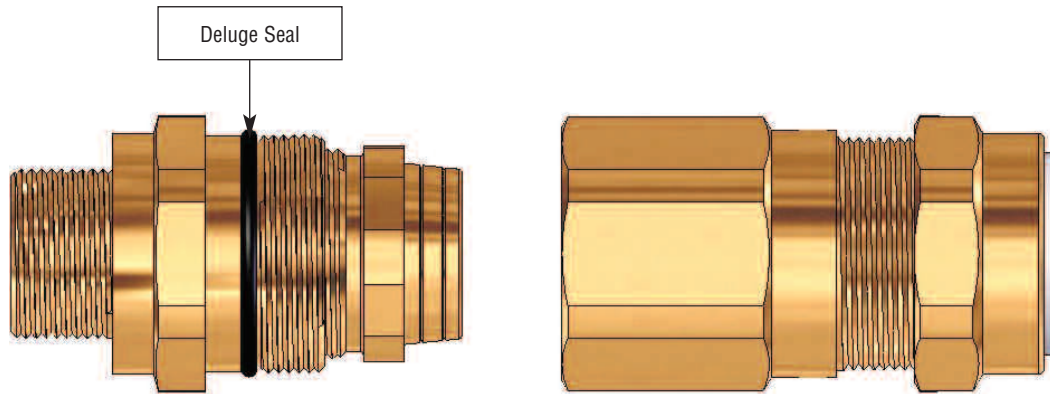

The results of the tests that CMP has had carried out confirm that its range of Deluge Protected Cable Glands can be safely specified for use in deluge conditions, in the sure knowledge that their long term performance will maintain protection against the ingress of water. This has been a major factor in the decision making process of a number of major Clients on key projects in both the offshore and

marine industry as well as other exposed onshore facilities. Cable Gland products that feature a deluge seal are not only intended for the offshore oil and gas industry, but are also equally suitable for use in the Water Treatment industry, or anywhere where the process equipment may be subject to occasional submersion or flooding.

The specific range of CMP Cable Glands which fully comply with the Deluge Test specification DTS01 includes, but is not limited to :-

- Triton CDS (T3CDS & T3CDSPB family) Armoured Cable Gland
- E1* Series Deluge Option (e.g. E1UD, E1FUD family) Armoured Cable Gland
- Protex 2000 (PX2K family) Armoured Compound Barrier Cable Gland.
- Sureseal 2000 (SS2K) Double Seal Unarmoured Cable Gland.
- Protex Sureseal 2000 (PXSS2K) Unarmoured Compound Barrier Cable Gland.
- A2F Unarmoured Cable Gland
- C2K Armoured Cable Gland
- D3K Armoured Cable Gland
- Marine Cable Glands for Wet Locations

Please refer to catalogue pages for specific product compliance.

HEALTH & SAFETY AT WORK

It is important that workers are able to operate and act in a safe manner, free from harm, and without risk from the environment in which they work, or the tools and machinery that they may operate. In the United Kingdom, the Health and Safety at Work Act 1974 lays down the general duties of employers, 'so far as is reasonably practicable' to protect the health, safety and welfare at work of all employees. This includes the provision of 'safe plant and systems of work', 'safe methods for the use, handling, storage and transport of articles and substances', 'necessary information, instruction, training and supervision', 'a safe and well-maintained workplace, including safe access and egress', and 'a safe working environment with adequate welfare facilities'.

Duties are placed on employees to take reasonable care of their own health & safety, and that of anyone who could be adversely affected by their 'acts or omissions at work' and to co-operate with their employer in steps to meet legal requirements.

The UK Health and Safety at Work Act also places duties on designers, manufacturers, importers and suppliers of articles for use at work, to ensure that items are safe for use and to supply necessary information about safe use and any testing results.

FUNCTIONAL SAFETY

IEC 61508 is the international standard for the functional safety of electrical, electronic and programmable electronic safety related systems.

by all links in the supply chain so that information about the system can be communicated using common terminology and system parameters.

It sets out the requirements for ensuring that systems are designed, implemented, operated and maintained to provide the required safety integrity level (SIL). Four SILs are defined according to the risks involved in the system application, with SIL4 being applied for the highest risks. The standard specifies a process that can be followed

Other standards related to the application of the IEC 61508 approach with specific relevance to particular sectors include IEC 61511 relating to process industries, IEC 61513 relating to nuclear industries, and IEC62061 relating to the machinery sector.

ELECTRICAL SAFETY IN THE WORK PLACE

Electrical Safety in the workplace should always be observed and never be underestimated. Local codes of practice or regulations may be in force to ensure that safety is maintained to eliminate the possibility of accidents arising from the danger of electricity. These dangers would include Electric Shock, Burns, Fire, Explosion and Arcing. In the United Kingdom the the Electricity Safety, Quality and Continuity Regulations 2002, introduced under Statutory Instrument No. 2665, and the Electricity at Work Regulations 1989 (EAW Regulations), which came into force on 1 April 1990, comprehensively deals with this subject. The purpose of these far reaching regulations is to ensure that the necessary precautions are taken against the risk of death or personal injury at work. This involves the imposition of duties on employers and employees in respect of electrical systems, equipment and conductors and the installation of the same.

Other national and international standards will also exist and these should be observed when required. IEC standards standards related to electrical safety include :-

IEC 61140 : Protection against electric shock – Common aspects for installation and equipment.

This standard covers the Basic rules, Requirements for protective provisions, Description of protective measures, Combination of protective measures, and special operating and servicing conditions

IEC 60364-4-41 : Low-voltage electrical installations - Part 4-41: Protection for safety - Protection against electric shock

This standard specifies essential requirements regarding protection against electric shock, including basic protection (protection against direct contact) and fault protection (protection against indirect contact) of persons and livestock.

IEC 60364-5-54 : Electrical installations of buildings - Part 5-54 : Selection and erection of equipment – Earthing arrangements, protective conductors and equipotential bonding.

This standard covers the basic requirements for earthing and bonding for safety purposes, and Protective conductors.

WIRING REGULATIONS AND EARTHING REQUIREMENTS

It is important to realise that regulations may differ from region to region or country to country and the need to comply with the local regulations or requirements should equally be recognised. There are several different standards in existence that may need to be followed, and in the United Kingdom BS 7671:2001, the IEE Wiring Regulations 16th Edition, and BS 7430:1998, the code of practice for earthing, are the applicable prevailing industry standards.

Depending on the situation it may also be necessary to follow the IEC standards, e.g. IEC 60364 - Electrical Installation in Buildings. Outside of the IEC arena, both the standards and the terminology which they use may differ considerably from the norm. In North America, for example “earthing” would normally be referred to as “grounding”.

The earthing of both the electrical systems, and also the metallic structures that they may come into contact with is a safety critical activity for obvious reasons. In the United Kingdom the BS 7430:1998 the code of practice for earthing, provides guidance on earthing of electrical supply systems, electrical installations and connected equipment, for the proper operation of systems and the protection of life. This covers basic principles, earthing methods and most general applications.

When using armoured cables (or conduit), both in onshore and offshore or marine situations, any metallic parts of the cable (or conduit) must be earthed, and this also applies to the lead covering used in lead sheathed cables. Wherever armoured cables are used it is normal practice to terminate the metallic armour, and / or lead cover (lead sheath) in the body of a metallic cable gland.

In accordance with BS 7671:2001, the IEE Wiring Regulations 16th Edition, both the cable and the accessories used for its connection must be tested to ensure compliance with the required safety levels. Cable glands and their fixing accessories and earth tags must be selected correctly to ensure that any risk of electric shock to personnel from coming into contact with live parts due to inferior earth connection is avoided. These earthing components must therefore be able to meet the minimum short circuit fault current withstand tests of the associated cable, and also be installed by competent personnel in line with good engineering practices

The cable armour is primarily for mechanical protection, and as already stated, this metallic armour must be effectively earthed. In general, the armour wire current carrying capacity must be equal to 50% of that of the largest current carrying conductor in the cable. The cable must be tested to determine its short circuit earth fault current rating, with the earth fault current being carried by the cable armour wires. Users should refer to the cable manufacturers design data for the short circuit fault current carrying capacity of the armour wires of each cable.

SWA cables

Cable glands connected to SWA cables must be able to provide earth continuity from the termination point of the armour in the cable gland body through to the equipment, if the enclosure is metallic, or via a metallic gland plate that is bonded to an external earth point, and / or directly to an external earth point via an earth tag. In the interests of safety most earthing systems associated with armoured cables will utilise a number of directly grounded external earth link cables connected to the earth tag which is in contact with the cable gland. Usually the cable would be earthed at one of its two ends as a minimum, and this approach ensures that in the event of a short circuit or earth fault in the cable, the quickest and most direct route to ground will be achieved as a result of the design philosophy adopted. When multiple cable entries are required in non-metallic enclosures (e.g. GRP terminal box) that do not have an external earth point, the user may prefer to engage an external earth cable between each metallic cable gland via an earth tag. At least one of the earth tags would also be used to connect an earth cable directly to ground. This method of providing earth continuity is sometimes referred to as a “daisy-chain” arrangement.

The earth tag described above must also be tested to ensure that it can withstand the equivalent short circuit earth fault current test rating of the cable and cable gland, otherwise the system will not have adequate (safety) earth protection.

SAFE EARTHING SYSTEMS

The need for safe earthing systems has been around for many years since the early development of the electrical power industry, but the much wider spread use of electrical energy for every imaginable application merely increases the need for an increase in the safety associated with earthing. In the United Kingdom the BS 7430:1998 code of practice for earthing should be observed.

Before we can discuss the problem of how to provide adequate and safe earthing systems, we should first consider the causes of earth faults. These can be caused by Lightning, Earth Leakage Current & Voltage, Differential Voltage Faults, Cable Capacitance Discharge, Circulating Currents, Fault Conditions from Loose or Inadequate Connections, or Human (Installation) errors, including the absence of the correct electrical protection devices, the installation of incorrect protection devices, incorrect installation, or failure to observe regulations. Good quality and reliable earthing systems are therefore essential to protect against the situations arising as previously mentioned.

LC / SWA or LC / PVC / SWA cables

In addition to the standard requirements for SWA cables, there is a set of special guidelines for lead covered cables intended for direct burial in the ground of hydrocarbons processing and refinery sites. These guidelines were introduced in the UK by the Oil Companies Material Association (OCMA) and responsibility for these was subsequently transferred to EEMUA, the Engineering Equipment and Material Users Association. The EEMUA Publication 133 “Specification for Underground Armoured Cable Protected Against Solvent Penetration and Corrosive Attack” defines the requirements of the petroleum industry for underground lead-sheathed cables for use where protection against solvent penetration or corrosive attack is required.

When the cable is LC / PVC / SWA the addition of the lead sheath introduces another metallic part of the cable that could effectively become live in the event of an earth fault or induced voltage and this must also be earthed. Any metallic parts used to terminate the lead sheath as part of the earth path must also be tested and documented to demonstrate that adequate levels of protection are maintained. In the case of LC / SWA cables the earth fault short circuit levels will be increased due to the parallel earth path existing between the armour wires and the lead sheath. It is important therefore that the whole cable gland and earth tag arrangement is tested on lead sheathed cable to ensure that the arrangement can withstand the overall affects resulting from short circuit in the cable armour / lead sheath.

If the cable glands and accessories chosen have not been tested, and are incorrect the connection of the earth circuit via the cable armour will become the weakest link in the system, and could result in potential fatality, lost time incident (LTI) or other accident.

Both cable manufacturers and cable gland manufacturers must cater in their design for the eventuality of an earth fault being carried via the cable armour, which is primarily intended for mechanical protection, but which may also be able to double up as the safe means to carry the earth fault conditions to ground. This may be the case with some Low Voltage cables as well as Medium & High Voltage cables, but in the latter two cases a higher fault current may be expected to occur in these cables.

Each cable that is expected to be able to carry an earth fault via its integral armour would have a rated current carrying capacity.

When a metallic cable gland is connected to an equipment enclosure which may also be metallic, or alternatively non-metallic, an Earth Tag may be required to ground the earth circuit via an Earth Link Cable or connect to another piece of equipment. These are intended to provide an earth bond connection as specified in BS 6121 : Part 5 : 1993, and subsequently EN 50262.

Here are the Short Circuit Fault Current Rating values for CMP slip on Earth Tags, when installed between the cable gland and equipment :-

CMP Brass Earth Tags

CMP Earth Tag Size	Short Circuit Ratings Symmetrical Fault Current (kA) for 1 second
20	3.06
25	4.00
32	5.40
40	7.20
50	10.40
63	10.40
75	10.40

CMP CIEL Cable Glands

In the event that MV and HV cables have a High Fault Current Carrying Capacity, via their Single Wire Armour configurations, the fault rating of the cable may be higher than those of the standard CMP Earth Tags. In this case it would not be advisable to use standard earth tags as it is important to match the rated fault current of the earth tag to the corresponding fault current rating of the cable armour. If the rating of the earth tag is greater than the fault current rating of the mating cable armour then using the earth tag would be acceptable, but the situation may be unsafe if the rating of the cable armour fault current carrying capacity is greater than that of the standard earth tag.

In such cases the perfect solution to overcome potential over heating and possible flash over, would be to use the CMP CIEL solution which involves the inclusion of an integral Cast Integral Earth Lug arrangement, in the cable gland assembly. The CMP CIEL range uses the same principal design concept as a standard CW, E1W, or E2W cable gland product in terms of sealing and / or hazardous area protection, but with additional facility for extra heavy duty earth connection.

This product design is available in Brass, Nickel Plated Brass, and Aluminium, and can be supplied in the Cable Gland Types CW CIEL, CWe CIEL, E1W CIEL, E1FW CIEL, E2W CIEL & E2FW CIEL.

The following fault current ratings apply to the CMP CIEL design type cable glands.

CMP CIEL Gland Size	Short Circuit Ratings Symmetrical Fault Current (kA) for 1 second
20S to 40	26.0
50S to 90	43.0

In addition to the recognised causes of earth faults described above, other environmental factors would also have an impact upon the overall electrical performance, and require reliable safe earthing systems in order to protect against them. These environmental considerations would include the possibility of Electromagnetic Interference (EMI / RFI), cross talk and induced voltages stemming from the positioning of cables

The ZEN range of products from CMP however goes much further than merely single point earthing, and allows great flexibility in the earth system, delivering optimum safety into the bargain. The CMP ZEN cable gland is available with or without the integral extra heavy duty earth lug featured in the CMP CIEL cable gland range, and this allows a whole range of options to be considered in terms of engineering solutions being adopted. Either in conjunction with other cable glands from the CMP CIEL family or not, the CMP ZEN product enables engineers to design safe earthing systems that can effectively deal with :-

It has been a known fact for many years in the UK power generation industry that unless special measures are taken to both segregate the cables in accordance with wiring regulations, and also isolate the metallic cable armour from running in continuous contact throughout the whole of the earthing system, interference or electrical noise was likely to spread around the extent of the plant.

- Cross Talk Noise Reduction
- The Electrical Separation of Main Earths
- Earth Fault Segregation
- Fault Current Reduction with Series Cable Resistance
- Electrical Noise Reduction in Instrument Cables
- Circulating Current Protection in Single Core Cables or Three Core Cables with unbalanced Load Conditions

To combat the sometimes intense levels of interference that had been experienced in practice, users were able to use the CMP ZEN range of Insulated Cable Glands, which would allow the cables to be earthed at one end only, for example the supply end, and insulated at the field end. ZEN is available with an insulating arrangement to ensure that no contact is made between the earth circuit carried through the cable armour and the electrical enclosure which the cable enters. This isolation of the cable armour at one end of the cable is sometimes referred to as single point earthing.

It may also be of interest to note that versions of the ZEN cable gland range are available from CMP Products which have been tested approved and used in containment areas of the Nuclear Power Generation industry.

CE MARKING

CE Marking was introduced to enable the free movement of goods, products and equipment within the European Union. When applying the CE mark to any item, the manufacturer is declaring that it complies with the requirements of all applicable European Directives. The CE mark should only be applied when the type of product falls

within the scope of the Directive that is detailed in a corresponding EC Declaration of Conformity.

The following EC Directives could be considered as being applicable to the majority of electrical equipment :-

Directive 73/23/EEC	-	The Low Voltage Directive (LVD)
Directive 89/336/EEC	-	The Electromagnetic Compatibility (EMC) Directive
Directive 2002/95/EC	-	The Restriction of Hazardous Substances (RoHS) Directive
Directive 2002/96/EC	-	The Waste Electrical & Electronic Equipment (WEEE) Directive
Directive 94/9/EC	-	The Equipment intended for use in Potentially Explosive Atmospheres (ATEX) Directive

Whilst cable glands are intended for the connection of electrical cables, and after installation become an integral part of the electrical system, they are not electrically connected to the cable conductors. They are primarily mechanical devices used in the sealing of cables entering electrical equipment. In the case of armoured cables, their application involves the termination of the metallic armour and in this

case may only be subject to a current carrying function in the event of an earth fault. The applicability of the above Directives in respect of CMP cable glands is fully explained in the following paragraphs, and in the case of the ATEX Directive 94/9/EC, further information can be found in the Hazardous Area section of this catalogue.

LOW VOLTAGE DIRECTIVE

The original Low Voltage Directive (LVD) 73/23/EEC was introduced to ensure that electrical equipment within certain voltage limits both provide a high level of safety and protection for European citizens. The Directive covers electrical equipment designed for use with a voltage rating of between 50 and 1000 V for alternating current and between 75 and 1500 V for direct current.

The Directive provides essential health and safety requirements for the range of products within its scope, ensuring that the electrical

equipment is safe in its intended use. For most electrical equipment, the emissions of Electromagnetic Fields are also under the domain of the Low Voltage Directive.

Directive 73/23/EEC was re-issued under the new document 2006/95/EC but the text content remained unchanged.

Cable glands are passive elements of the electrical installation and are not considered to fall under the scope of the Low Voltage Directive.

EMC DIRECTIVE

The Electromagnetic Compatibility (EMC) Directive - 89/336/EEC

Although originally enacted in 1989 under the Directive 89/336/EEC, the EMC Directive has witnessed significant development since it first came into force on 1st January, 1992.

The EMC Directive has been amended several times under the subsequent Directives 92/31/EC, 93/68/EEC, 98/13/EC, and 99/5/EC. A new EMC 2004/108/EC Directive became effective on 20th July, 2007.

The EMC Directive requires that products must not generate unwanted electromagnetic pollution, or interference, and that products must be immune to a reasonable amount of interference.

Cable glands, which are not considered to fall under the scope of the EMC as they are neither capable of emitting electromagnetic interference nor being susceptible to it, may be used to contribute to

the electromagnetic compatibility of installations. Several industry studies have been conducted as to the effect of cable terminations in systems that are required to provide a specified degree of EMC protection.

CMP Products has carried out 3 Metre Class B Radiated Emission Measurement tests in accordance with EN 55022 to verify the performance of cable sealing glands that are terminated on screened and armoured cables using a 360° termination of the metallic cable sheath. The typical results of these CNE measurement tests are shown below, with the noise reduction performance levels seen to be significantly improved in figure ii when the cable has been correctly terminated in the CMP cable gland. Figure i. shows that when the cable has not been terminated in such cable gland, the noise levels recorded are far higher than the acceptable Class B noise floor shown.

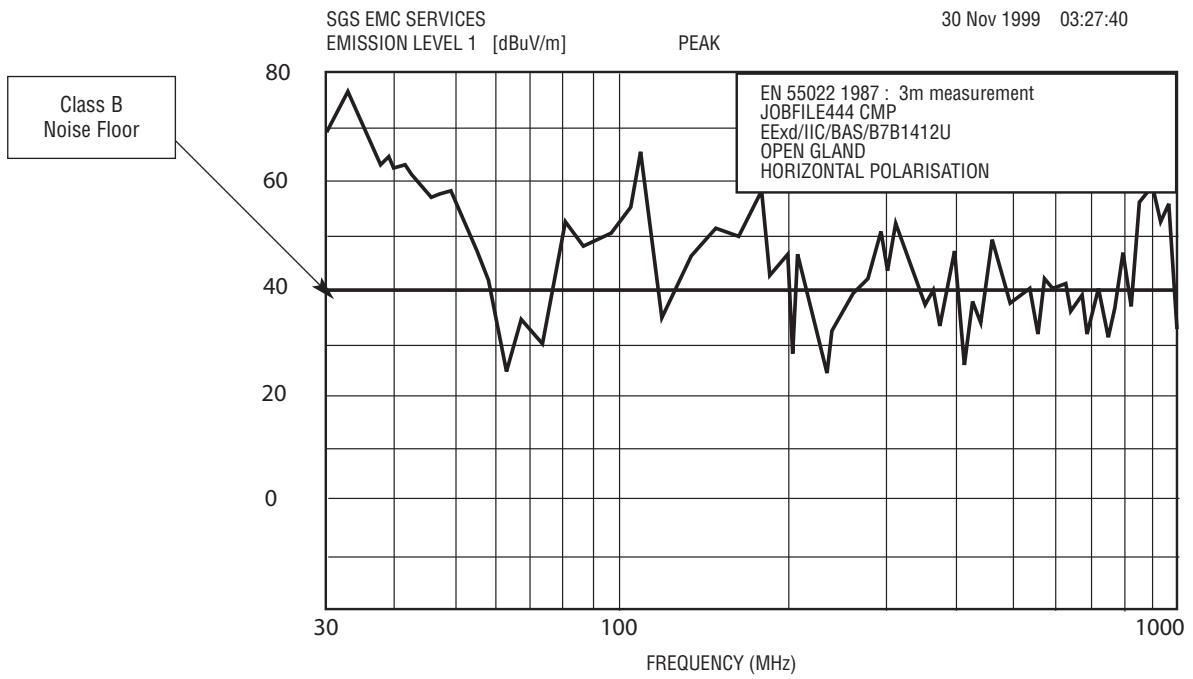

Comparison Noise Emission Measurement Test - CMP Armoured Cable Gland. Cable Without Cable Gland Terminated & Sealed .

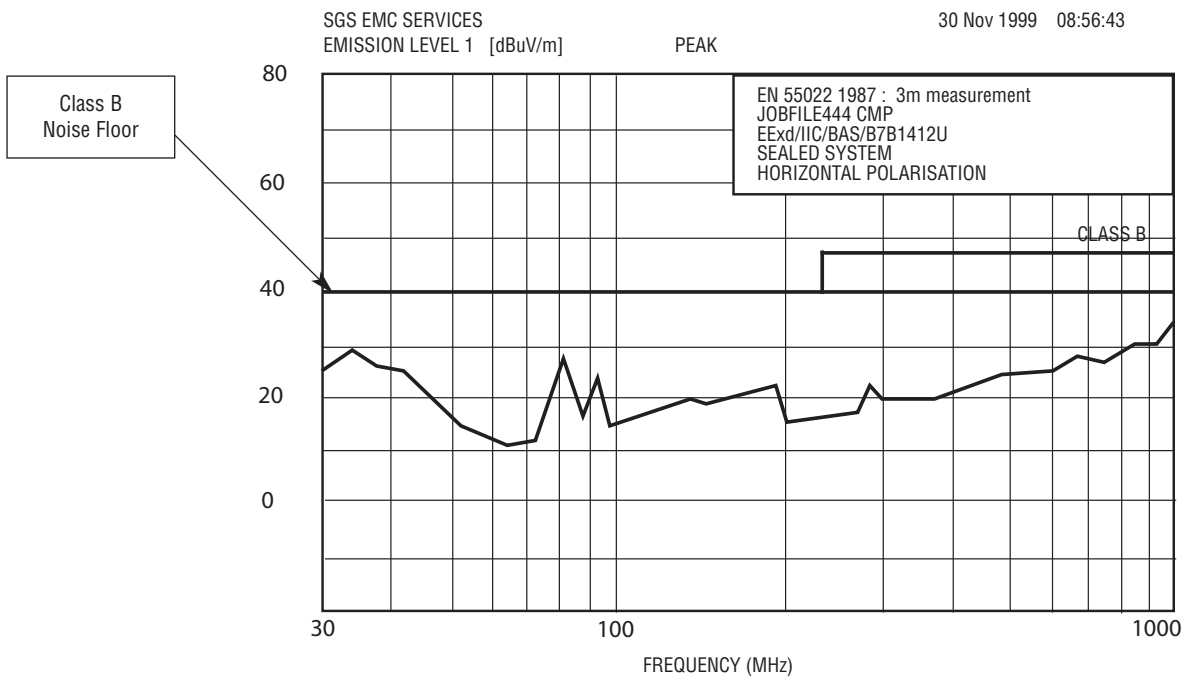

Comparison Noise Emission Measurement Test - CMP Armoured Cable Gland. Cable With Cable Gland Terminated & Sealed

For further information, reference should also be made to applicable installation standards, e.g. IEC 61000-5-2: - Electromagnetic compatibility (EMC). Installation and mitigation guidelines - Earthing and cabling.

RoHS & WEEE DIRECTIVES

Restriction of Hazardous Substances (RoHS) Directive 2002/95/EC

The RoHS directive of 2002 became effective on July 1, 2006 and as amended by Commission Decision 2005/618/EC this prohibits the presence in "electrical and electronic equipment," of the six substances listed in the table below.

Substance	Maximum Composition (by weight)
Lead *	0.1%
Mercury	0.1%
Cadmium	0.1%
Hexavalent Chromium	0.1%
Polybrominated Biphenyls	0.1%
Polybrominated Diphenyl Ethers	0.1%

* As an alloy element in steel containing up to 0.35% by weight, in aluminium alloy containing up to 0.4% by weight and in copper alloy containing up to 4% by weight, lead is permitted under an exemption detailed in Commission Decision 2005/618/EC. Although cable glands are incorporated into the electrical systems, they are not considered to come within the scope of this directive, as they are mechanical cable handling devices designed only to seal and terminate the metallic cable armour.

Nevertheless CMP Products is able to confirm that its range of cable gland products would comply with the requirements of this directive if it did fall under its scope.

Waste Electrical and Electronic Equipment (WEEE) Directive 2002/96/EC

The WEEE directive was also enacted in 2002 and became effective on August 13, 2005. The directive applies to equipment which is dependent on electric currents or electromagnetic fields in order to work properly and also to equipment for the generation, transfer and measurement of such currents and fields designed for use with a voltage rating not exceeding 1000 V for alternating current and 1500 V for direct current.

As such cable glands by design and function do not fall under the scope of this directive, because they are a passive element in the electrical circuit and do not rely upon a source of electrical current or electromagnetic fields in order to function.

CMP Products, being a world leading manufacturer of cable glands and consistent with its legal and moral responsibilities, has reviewed its extensive range of cable glands to verify that its full product portfolio is outside of the scope of this directive.

QUALITY MANAGEMENT

CMP Products is a quality assured company, and is responsible for its own design. Its Quality Management System is approved to ISO 9001 : 2000, and the 3rd party audit and approval is conducted by Bureau Veritas.

ISO 9001

BUREAU VERITAS
Certification



HEALTH, SAFETY & ENVIRONMENT

The Health Safety and Environmental Management System employed by CMP Products has been developed to meet the requirements of :-

OHSAS 18001 1999: Occupational health and safety management systems – Specification.

OHSAS 18002 2000: Occupational health and safety management systems – Guidelines for the implementation of OHSAS 18001.

ISO 14001 Environmental Management Systems.

CABLE GLAND SELECTION GUIDELINES

There are many factors to consider when selecting cable glands for industrial installations. Neglecting to pay due attention to some of these factors may cause unnecessary anxiety at a future point in time when the equipment and cables have been delivered on site, but for example the cable glands have either been forgotten to be ordered or it is discovered that they are the incorrect type or size at the very point when they are needed the most. Good advice would be to allocate some value added planning and preparation time to the subject of cable gland selection so as to avoid the great inconvenience which is likely to occur at a critical point in time. In the event that a user or contractor is in possession of a cable schedule that requires a cable gland selection and sizing process to be carried out, CMP Products would be more than happy to assist in carrying out this process at no cost to the enquirer. Please contact CMP Products for further information on this subject.

Here is a summary of some aspects to carefully consider when selecting cable glands.

- Identify the type of cable to be used.
- Check the construction, size & material properties of the cable.

When the cable is armoured, verify the following :-

- Check the type and material of the cable armour (*)
- Check the short circuit fault current rating of the cable armour (**)
- Check the actual diameter of the inner bedding (where present) against this catalogue.
- Check the actual diameter of the lead covering (where present) against this catalogue.
- Check the actual size of the overall cable diameter against this catalogue.
- Check the size and type of armour or braid (where present) against this catalogue.
- Check any special environmental requirements in relation to corrosion protection.
- Check the material of the mating electrical enclosures to eliminate dis-similar metals.

- Consider whether any protective plating is required to be applied to the cable gland.
- Check the type and size of the cable entry hole in the mating electrical equipment.
- Check the ingress protection rating of the electrical equipment or site standard
- Check whether a single seal or double seal cable gland is required.
- Check whether an entry thread seal is required for IP66 (or IP67/IP68) conditions.
- Check whether fixing accessories such as locknuts and serrated washers are required.
- Check whether earth tags are required. (**)
- Check whether shrouds tags are required.
- Select a corresponding cable gland type from this catalogue.
- For installations in Hazardous Areas, special considerations should be taken into account to ensure compliance with national or international codes of practice.
- Check whether a thread conversion adaptor / reducer is required to make the installation.
- Select corresponding adaptors or reducers from this catalogue.
- Check whether any stopper plugs are required to close unused cable entries.
- Select corresponding stopper plugs from this catalogue.

Note (*) : If the cable armour is of a non standard material, e.g. Aluminium Wire Armour, it may be necessary to consider an alternative cable gland material, e.g. Aluminium.

Note (**): For certain medium voltage and high voltage cables where the fault current carrying capacity of the cable armour is greater than that of the standard earth tag it may be necessary to consider a cable gland utilising the CMP heavy duty Cast Integral Earth Lug (CIEL) option which can be identified in the body of this catalogue.

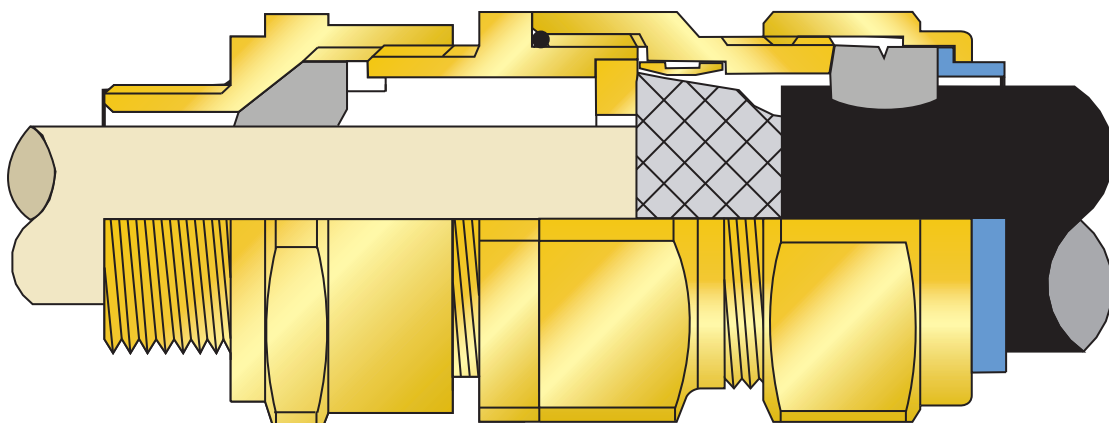

HOW TO ORDER

On each of the main product pages in this catalogue you will find a cable gland selection table which includes the part number, typically of a standard metric product, for ordering purposes. The part number

is composed of the CMP Size, Type Number, and Standard Suffix. The table below is provided to allow the selection of alternative materials, thread types, thread sizes and other options.

e.g. 1: 20 - E1W - Brass, with M20 entry thread

e.g. 2 : 20 – E1FW – Nickel Plated Brass, with M20 entry thread

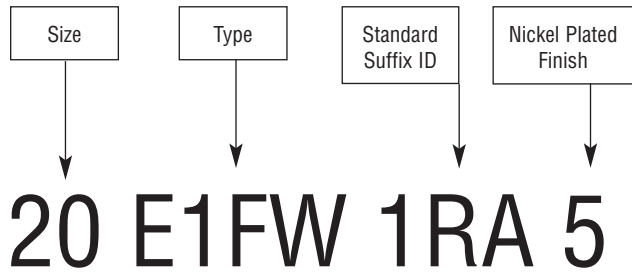
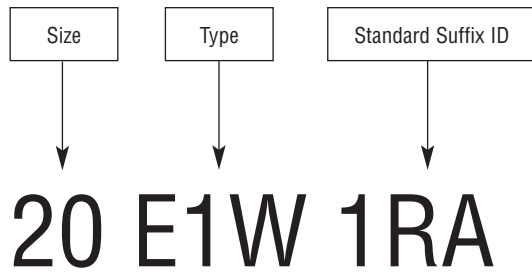

Cable Gland Size & Type	Supply Type	CMP STD Suffix	Options		Material	Entry Thread Type		Entry Thread Size					
								Imperial	PG	NPT / BSP / NPSM	Metric		
e.g. 20E1FW	1 - Gland	RA	D	Deluge Seal	0	Brass	1A	Metric	1A	1/2"	7	3/8"	-
-	2 - Pack	-	B	Brazilian Certification	1	Aluminium	1	Imperial	1	5/8"	9	1/2"	16
-	-	-			2	Nylon	2	PG	2	3/4"	11	3/4"	20
-	-	-			3	Mild Steel	3	NPT	3	1"	13.5	1"	25
-	-	-			4	Stainless Steel	4	BSP	4	1-1/4"	16	1-1/4"	32
-	-	-			5	Brass - Fully Nickel Plated	5	NPSM	5	1-1/2"	21	1-1/2"	40
-	-	-			6	N/A	6	BSPT	6	2"	29	2"	50
-	-	-			7	Brass with Nickel Plated Entry Component	-	-	7	2-1/2"	36	2-1/2"	63
-	-	-			8	Zinc Plated	-	-	8	3"	42	3"	75
-	-	-			-		-	-	9	3-1/2"	48	3-1/2"	90
-	-	-			-		-	-	10	4"		4"	100

"Unless otherwise stated, for IEC products, the standard Hazardous Area certification marking includes ATEX and IEC Ex as a minimum – please refer to CMP Products if your requirement differs from the standard"

INTRODUCTION TO HAZARDOUS AREAS

The following information is intended as a guide to provide a minimum insight into Hazardous Area Equipment concepts and practice. National or International guidelines and/or Codes of Practice for Hazardous Area installations should always be referenced to ensure compliance with specific local requirements. In Europe the latest industry standard or Code of Practice for the selection and installation of electrical apparatus in flammable atmospheres is EN 60079-14 which reflects the global standard IEC 60079-14. Before putting equipment into service, users must familiarize themselves with the relevant codes of practice and construction standards applicable to their territorial operations, as well as the specific product certification details. Any Technical Product Data and Installation instructions provided by the equipment manufacturer should also be taken into consideration.

Equipment Manufacturers, who may have a general understanding of Hazardous Area regulations and practices, may give limited advice on requirements related to their own product range but beyond that further expert assistance should be sought. Nevertheless, it is reasonable to presume that personnel working in these areas and who may be responsible for installations, or guiding others in such installations, are fully qualified, with the necessary level of competency in this specialist field. It should be noted that in normal circumstances it is the Plant Owner or Operator (or the User) who must take full responsibility for the safe operation of the plant, and in this respect they should be well acquainted with prevailing regulations pertinent to their situation.

EXPLOSION HAZARDS

The danger of explosion exists when flammable materials are mixed with air, when they can form an explosive mixture. This can occur during storage, movement, process, production and manufacture of such flammable materials. The primary requirement is for the operator to prevent conditions where a flammable mixture is released to the atmosphere. However, as there is some risk of such a situation taking place, special measures need to be taken in respect of electrical and non-electrical apparatus, to prevent the possible

ignition of flammable or explosive atmospheres. The employment of these measures should safeguard both the plant (or installation) and more importantly human life, as ignition can only occur when both a flammable atmosphere and the means for an ignition exist simultaneously. Such ignition may occur following an arc, spark or hot surface during the use of electrically powered equipment, although it should also be recognized that non-electrical equipment may also be the source of ignition.

The three ingredients which together will give rise to an explosion taking place :-

- a. Flammable material,
- b. Air and,
- c. Ignition source,



form what is commonly known as the Fire Triangle.

PRINCIPLES OF PROTECTION

In order to provide an operation that can function in the safest possible manner the protection of workers, the environment, and the plant itself relies upon three key ingredients in the development and planning stage of a new plant project. These are :-

Furthermore in respect of the electrical equipment that is installed, the following should also be observed :-

- 1, The reduction in risk by the plant designers taking all hazard risks into account.
- 2, The installation of the electrical apparatus in a non-hazardous area, or if this is not possible in the least hazardous area.
- 3, The electrical apparatus and its wiring and connections shall be designed, installed, operated and maintained in such a way to prevent it from becoming a source of ignition.

- A, The construction and installation should comply with the appropriate regulations and requirements for installation in non-hazardous or industrial installations.
- B, The electrical equipment must be installed in accordance with the manufacturer's instructions, and also any limitations of the corresponding certification documentation.
- C, On completion of the construction and installation an initial inspection shall be carried out.

RISK ASSESSMENT PROCESS FOR HAZARDOUS AREAS

In addressing the factors of risk in the hazardous area a process of Risk Assessment and Risk Control should be undertaken to ensure a safe working environment. This process will involve identifying who and what is likely to be at risk of harm, and will include an evaluation of these risks. Part of the process will entail identification of the hazards involved, the possible sources of release of flammable materials, the grades of release, the potential ignition sources, and what measure may be taken by design or other means to minimise or eliminate risks. Findings and conclusions from the Risk Assessment should be documented for subsequent examination, and the assessment process should be reviewed periodically and revised if necessary. Existing precautions and contingencies that are already in place should be reviewed to verify whether they are adequate, or if further risk prevention measures need to be implemented.

In addressing the factors of risk in the hazardous area a process of Risk Assessment and Risk Control should be undertaken to ensure a safe working environment. This process will involve identifying who and what is likely to be at risk of harm, and will include an evaluation of these risks. Part of the process will entail identification of the hazards involved, the possible sources of release of flammable materials, the grades of release, the potential ignition sources, and what measure may be taken by design or other means to minimise or eliminate risks. Findings and conclusions from the Risk Assessment should be documented for subsequent examination, and the assessment process should be reviewed periodically and revised if necessary. Existing precautions and contingencies that are already in place should be reviewed to verify whether they are adequate, or if further risk prevention measures need to be implemented.

SOURCES OF RELEASE

Sources of release may originate from almost anywhere in the process or storage area of a hazardous area site. Flammable materials may be released from Pumps, Pipes, Flanges, Valves,

Sampling Points, or other similar apparatus. The release may be caused for example by either seal failure at joints to flanges, ruptures to pipe work, or inadvertent operations error.

GRADES OF RELEASE

Factors taken into account during the Area Classification process include Grades of Release which are defined as follows :-

Continuous – a release which is either continuous or is expected to occur for long periods.

Primary – a release which can be expected to occur periodically or occasionally during normal operation.

Secondary – a release which is not expected to occur in normal operation and if it does occur it is likely to do so infrequently and for short periods.

FLAMMABLE MATERIAL PROPERTIES

A flammable mixture can be classified for explosion protection under several key characteristics including its Relative Density, Flash Point, Flammable Limits, Ignition Energy and Ignition Temperature. In order to ensure correct assessment in terms of risk and correct selection of apparatus to be used in the hazardous areas, it is important to understand all of the particulars of the flammable materials being handled in any process plant. For example, it may be vital to know the

temperature of ignition by hot surfaces, the flash point, or the lower explosive limit of the flammable mixture that a particular process will become exposed to before accurate and proper risk assessments can be made. The data relating to the particulars of a given substance may be extracted from recognised standards that define the characteristics of the most commonly handled or known substances. The definitions of the main characteristics are shown below.

Relative Density : The density of a gas or a vapour relative to the density of air. The result would be displayed in reference to air having a value equal to 1.

Flash Point : The minimum temperature at which a liquid give off sufficient vapour to form an explosive atmosphere when tested in a set of standard test apparatus.

Flammable Limits : The upper and lower percentages of gas / air mixture at normal atmospheric temperature and pressure which will burn if ignited.

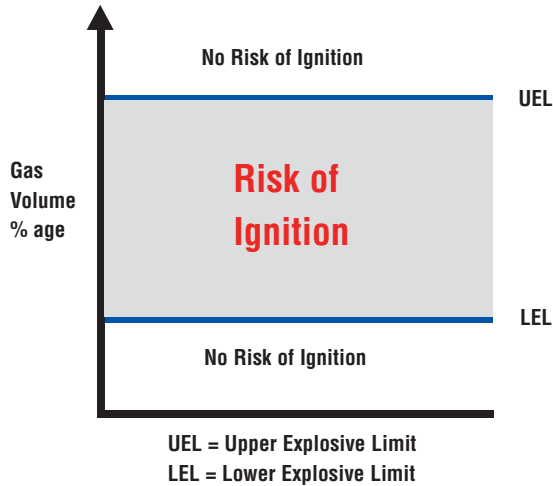

Ignition Energy

The spark energy which will ignite the most easily ignited mixture of a test gas with air at atmospheric pressure in a set of standard test apparatus. The spark energy of the ignition is also related to the intensity of explosion, i.e. a highly flammable gas mixture can be ignited with a low energy spark to create a high intensity explosion.

Ignition Temperature (Auto Ignition Temperature)

Ignition temperature, or AIT as it is also known, is defined as the lowest temperature determined by a standardised method, at which the most explosive mixture of the given substance and air will automatically ignite when in contact with, or in the presence of, a heated surface. In this situation the flammable mixture spontaneous combustion will occur without the presence of an independent ignition source.

The Ignition Temperature of flammable materials (gases, vapours and liquids) is defined in IEC 60079, along with the corresponding gas group. Examples of ignition temperatures for commonly occurring

flammable mixtures are town gas (surface methane)/air, which ignites at over 600°C, and petrol/air which ignites at approximately 250°C.

GAS GROUPS

The categorisation of Gas Groups for Electrical Apparatus which includes all potentially explosive gas, vapour, or chemical would normally be found in the appropriate National or International Code of Practice related to the users location. A selection of typical gas groups is shown below. Users may refer to PD IEC 60079-20, "Electrical apparatus for explosive gas atmospheres : Data for flammable gases and vapours, relating to the use of electrical apparatus", for a comprehensive collection of reference characteristics.

Gas Group	Typical Gas Name
IA	Methane (Firedamp) - Mining
IIA	Industrial Methane, Propane, Petroleum & Hydrocarbons
IIB	Ethylene & Town Gas, Coke Oven Gas
IIC	Hydrogen, Acetylene, Carbon Di-Sulphide

SOURCES OF IGNITION

Ignition of a flammable mixture may occur following an arc, spark or hot surface during the use of electrical apparatus. Arcs can result from the discharge of stored energy or from switching contacts. Although electrical equipment can be one of the sources of ignition, it should also be recognized that non-electrical equipment may also be the source of ignition. Hot surfaces sufficient to cause ignition can arise from electrical enclosures, or components, or even some types of mechanical equipment. In addition ignition could also be initiated by frictional sparking and electrostatic action.

Other sources of ignition energy are open flame, stray electric currents, lightning, compression, engine exhausts, heat from chemical reactions, spontaneous combustion, & heat from the sun.

Taking into consideration that equipment that is intended for use in explosive atmospheres must be specially protected so as to avoid becoming the source of ignition, the following categorisation of apparatus has been adopted.

Apparatus Group	Application
1	Underground Mining
2	Surface Industries

HAZARDOUS AREA EQUIPMENT

For equipment which is to be used in areas where flammable atmospheres may occur, a number of standard methods of protection against ignition have been established. These have been adopted into

construction standards, or codes, which allow manufacturers to make apparatus of a uniform type and have this equipment or apparatus tested & certified for compliance with the standards.

The principle methods of protection are briefly summarised as follows :-

Designed to prevent the flammable mixture reaching a means of ignition.	Ex 'n' or Ex 'nR' (Restricted Breathing)
	Ex 'm' Encapsulation
	Ex 'p' Pressurisation
	Ex 'o' Oil Immersion
Designed to prevent any ignition from arising.	Ex 'e' Increased Safety
	Ex 'n' or Ex 'nA' Non Sparking
	Ex 'm' Encapsulation
Designed to prevent any ignition from spreading.	Ex 'd' Flameproof Enclosure
	Ex 'q' Powder or Sand Filling
Designed to limit the ignition energy of the circuit.	Ex 'i' Intrinsic Safety

A comprehensive range of definitions of these forms of protection is available on page 39 & 40 of this catalogue.

APPARATUS SURFACE TEMPERATURE CLASSIFICATION

Classification of the maximum Surface Temperature of apparatus has been established internationally to create a uniform reference table. The following Temperature Classifications are those defined in the IEC Standards for Group II Electrical Apparatus :-

Temperature Classification	Maximum Surface Temperature of Apparatus (°C)	Ignition temperature of Gas or Vapour (°C)
T1	450	> 450
T2	300	> 300
T3	200	> 200
T4	135	> 135
T5	100	> 100
T6	85	> 85

(Unless otherwise specified on apparatus selected, the maximum Ambient Temperature is taken as being 40°C, in line with IEC Standards).

The purpose of the Temperature Classification is to place apparatus into an appropriate category according to its' specific thermal properties when exposed to the worst case conditions. Often this takes into account such things as maximum Ambient Temperature and maximum Operating Voltage with a +10% over voltage or an overload condition applied. In some cases the external surface temperature measurement is used to determine the T rating. This is not always the case, however, since certain forms of equipment

protection have their temperature measurement taken internally as is the case with most Ex e apparatus.

With the Ignition Temperature of the flammable mixture known by the user, he must ensure that the maximum Surface Temperature (T) Rating of the apparatus selected is lower than the limiting temperature of the flammable atmosphere identified as potentially being present.

AMBIENT TEMPERATURE

The Ambient Temperature is the Surrounding Temperature of the environment in which the equipment is installed, whether indoors or outdoors. A given piece of Electrical Equipment will be approved for a stated maximum ambient temperature in which it is safe to operate. For example under the IEC 60079 series the normal ambient temperature range for Ex d equipment would be -20°C to +40°C, unless otherwise stated on the product certification. In some cases

the maximum (or minimum) permitted ambient temperature will be adjusted taking into account any temperature rise under normal operation and the surface temperature rating of the equipment. The maximum (or minimum) ambient temperature will be stated on the hazardous area certificate, described as T amb, if it differs from the upper or lower limits of the IEC standards.

CLASSIFICATION OF HAZARDOUS AREAS ACCORDING TO IEC 60079-10

Hazardous area classification is a structured means of assessing risks and instigating appropriate preventative measures to prevent ignition of flammable mixtures. Codes of practice have been established for the classification of potential hazards and similar codes deal with the selection, installation and maintenance of suitable equipment to protect against these hazards. The codes of practice may be locally, nationally or internationally recognised documents. These documents will list the generic methods of protection which may be used to achieve an acceptable level of safety.

The process of classifying an installation or plant into Zones whereby the probability of flammable atmospheres (or hazardous areas) arising is assessed is known as Area Classification. IEC 60079-10 is the prevailing International Standard which addresses this subject.

Hazardous Area Classification Plan

A set of documents providing information on the hazardous areas of the plant is created.

As a minimum this shall comprise of :-

- i. Area Classification Drawings,
- ii. Details of the Flammable Substances being stored, handled, or processed,
- iii. Details of the Sources of Release
- iv. Information on the Areas of Risks, and in the case of enclosed spaces,
- v. Information relating to the ventilation and air conditioning design, which affect the classification and extent of hazardous locations.

Hazardous Area Classification Drawings

A set of drawings showing to scale the complete layout of the facility, marking the extensions of the hazardous locations defined based on the specific data associated with the flammable substances, sources of release and areas of risk for all elevations.

Standard Symbols for Identification of IEC Hazardous / Classified Areas

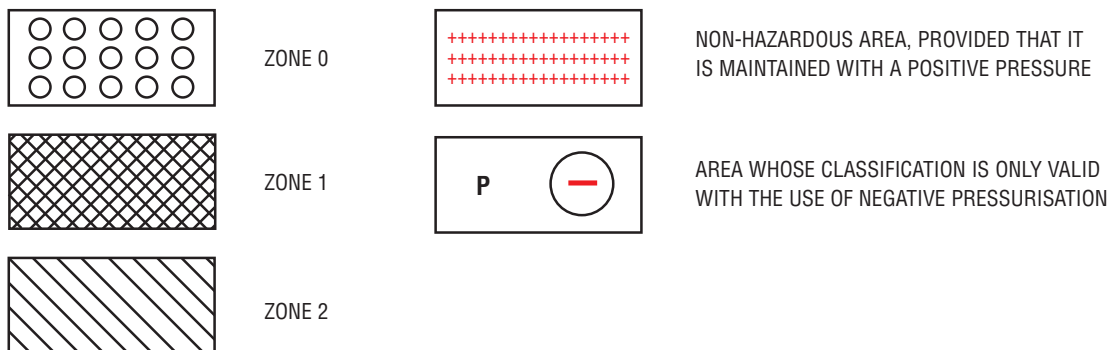

ZONE DEFINITIONS

Under IEC rules, the definitions of the Zoning of Hazardous Areas and the forms of protection which are permitted to be used within them in accordance with EN 60079-10 are typically recognised in the case of gas and vapour hazards, as follows :-

Zone 0

An area where an explosive gas atmosphere is present continuously or is present for long periods of time (e.g. 1000 hours or more per year)

Zone 1

An area where an explosive gas atmosphere may exist under normal operating conditions (e.g. 10 - 1000 hours per year)

Zone 2

An area where an explosive gas atmosphere is not likely to exist under normal operating conditions, but if it does it will exist only for a short period of time (e.g. less than 10 hours per year)

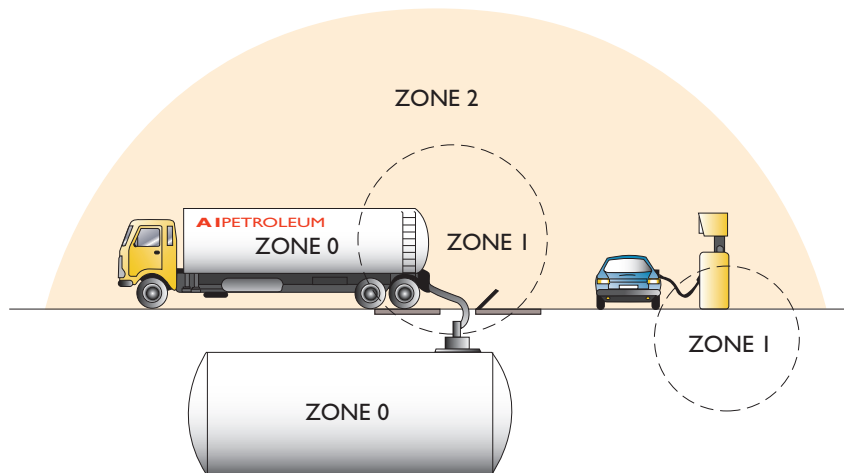

HAZARDOUS AREA FORMS OF PROTECTION

Generally, electrical safety is ensured by the implementation of one of two considerations, i.e. that electrical apparatus be located where reasonably practicable outside hazardous areas, and that electrical apparatus be designed, installed and maintained in accordance with measures recommended for the area in which the apparatus is located. There are several forms of protection, laid down in specified apparatus standards, that can be adopted by equipment designers when creating a product, equipment or system intended for use in flammable atmospheres. An explanation of each of these forms of protection are detailed as follows :-

FORM OF PROTECTION Ex 'd' (Flameproof Enclosure Type 'd') IEC 60079-1 :-

Flameproof Type 'd' Equipment which may include arcing and sparking (or incandive) devices and can have explosive mixtures present internally. The enclosure construction is designed to contain an internal explosion and prevent transmission of sufficient energy to cause an explosion external to the equipment. Any joints, covers or openings are constructed with flameproof paths which must be periodically inspected and continuously maintained in order to retain the integrity of the form of explosion protection.

FORM OF PROTECTION Ex 'e' (Increased Safety Enclosure Type 'e') IEC 60079-7 :-

Whilst explosive mixtures may enter the equipment, the enclosure is not designed to withstand an internal explosion. Instead the likelihood of a fault condition, which could result in ignition of explosive mixtures, is significantly reduced by the following measures. The (non-incandive) components used in the apparatus shall not produce arcs or sparks or dangerous temperatures in normal working conditions. The apparatus or equipment usually has a maximum voltage rating of 11kV. Electrical connections and insulation are selected for high reliability and effectiveness. The level of protection against the ingress of dirt and moisture ensures that the prospect of component contamination is substantially reduced. Two fundamental requirements of Ex 'e' protection are that the equipment shall be protected to IP54 minimum for Gas / Vapour (IP6X for Dust Hazards), and have an Impact Strength of 7Nm minimum. As this form of protection can be used in both Zone 1 and Zone 2 Areas, it is often preferred to Ex 'd' due to the need for reduced levels of maintenance and inspection. Another major consideration is that Ex 'e' apparatus is generally constructed from lighter weight materials, which often leads to lower cost.

FORM OF PROTECTION Ex ‘de’

IEC 60079-1 & – IEC 60079-7 :-

Primary Flameproof Type ‘d’ Enclosure with Secondary Increased Safety Type ‘e’ Protection, allowing reduced frequency of periodic maintenance and inspection cycle because of the ‘e’ philosophy strategically employed. In the case of Flameproof Type ‘d’ Enclosures having an Increased Safety Type ‘e’ Terminal Chamber, ‘line barriers’ would normally be utilised between the Type ‘d’ and Type ‘e’ compartments creating an indirect cable entry interface. Consequently this would permit the use of Cable Glands with Increased Safety Type ‘e’ form of protection.

NOTE : Other forms of primary and secondary protection methods exist. This example has been included to demonstrate a commonly used application of the concept.

CODE OF PROTECTION Ex ‘ i ’

IEC 60079-11 :-

Intrinsically Safe Apparatus (Sub grouped into Ex ia and Ex ib) of these types incorporate circuits which due to their low spark energy potential are not capable of igniting an explosive mixture. Ex ib equipment is safe under one fault condition and can be used in Zone 1 Areas. Ex ia equipment is safe under two fault conditions and can be used in Zone 0 Areas. The Intrinsically Safe components or circuitry may be housed in an enclosure having another form of protection e.g. Ex e or Ex d, although the enclosure need not always be an approved item in its own right. In all cases it is important that the integrity of the housing or enclosure is maintained in accordance with the form of protection pertaining to it.

CODE OF PROTECTION Ex ‘m’

IEC 60079-5 :-

Encapsulation of arcing and sparking components or apparatus in a fashion which ensures that there is no exposure to explosive mixtures which may be present, and the surface temperature is controlled under normal and fault conditions, thus preventing ignition from occurring.

CODE OF PROTECTION Ex ‘n’

EN 60079-15 :-

Permitted only in areas where the likelihood of a flammable atmosphere is remote (Zone 2), Non incandive Type ‘n’ Apparatus is divided into four sub-forms as follows :-

- Non-Sparking – Ex nA – Components selected for non arcing or sparking.
- Enclosed Break – Ex nC – Incandive components, e.g. lampholders, enclosed and sealed to exclude gas or vapour from reaching ignition capable components.
- Energy Limitation – Ex nL – Low energy circuitry eliminates potential for ignition.
- Restricted Breathing – Ex nR – Relies upon the sealing and gasketing of the apparatus to ensure that the flammable mixture is kept away from any hot surfaces and ignition capable components so that it does not enter the enclosure in sufficient quantity to reach the specific L.E.L. documented.

Apparatus with the type ‘n’ protection method is considered to be non incandive in that it does not usually generate arcs or sparks or dangerous temperatures in normal service. Internal component temperatures must be controlled and wiring connections and terminals selected with ‘Non-sparking’ in mind. The concept shares similarities with the Ex e philosophy but is suitable only for use in Zone 2 (or 22 where the apparatus may also be approved for dust hazards). This apparatus type is not designed to withstand explosion, and would usually employ a light weight enclosure of metallic or non metallic construction, but one that ensures a high Ingress Protection level is maintained.

In cases where the internal surface temperatures of components cannot be controlled in line with prescribed T ratings, the Restricted Breathing method (Ex nR) is adopted whereby joints and covers have tightly fitted seals and gaskets to provide the additional protection. This effectively excludes any external explosive mixtures which may be present from entering the enclosure and reaching the hot components. The ‘Restricted Breathing Enclosure’ technique is typically used in the design and construction of certain types of Lighting Equipment for Zone 2 Areas where the operating temperature of the lamp would otherwise be dangerously high. With this form of protection the user is responsible for ensuring that the cable entry device (Cable Gland) provides an adequate gas tight seal and maintains the integrity of the equipment protection code as detailed under the applicable standard to which it was tested and certified.

CODE OF PROTECTION Ex ‘o’

EN 60079-18 :-

Permitted only in areas where the likelihood of a flammable atmosphere is remote (Zone 2), Type ‘o’ Apparatus where the sparking components are immersed in Oil and controlled venting is also a feature, for example in early forms of switch gear.

CODE OF PROTECTION Ex ‘p’

EN 60079-2 :-

Pressurised or purged Apparatus Type ‘p’ rely on a combination of a positive static pressure applied inside the enclosure and a continuous flow of air or inert gas to expel any explosive mixture which may have entered. The system relies essentially on purging schedules and monitoring systems to ensure the reliability and effectiveness of the overall protection.

CODE OF PROTECTION Ex ‘q’

EN 60079-5 :-

Powder filled Enclosures Type ‘q’ which house arcing and sparking (or incandive) devices and include a vent. Often used to contain the energy released from the failure of electrical or electronic components such as the breaking of a fuse. This form of protection is often associated with components inside Ex e apparatus for example lighting control gear.

COMBUSTIBLE DUST HAZARDS

IEC 61241 - Electrical apparatus for use in the presence of combustible dust.

Many dusts that are generated, processed, handled and stored are combustible. When ignited they can burn rapidly and with considerable explosive force if mixed with air in the appropriate proportions. When electrical apparatus is used in locations where combustible materials are present, it is important that suitable precautions are taken. In electrical apparatus, potential ignition sources include electrical arcs and sparks, hot surfaces and frictional sparks. To reduce the likelihood of ignition of the external explosive atmosphere, all such electrical apparatus should be adequately protected.

Areas where dust, flyings and fibres in air occur in dangerous quantities are classified as hazardous and are divided into three zones according to the level of risk.

Zone 20 An area in which combustible dust, as a cloud, is present continuously or frequently, during normal operation, in

sufficient quantity to be capable of producing an explosive concentration of combustible dust in a mixture with air.

Zone 21 An area, in which combustible dust, as a cloud, is occasionally present during normal operation, in a sufficient quantity to be capable of producing an explosive concentration of combustible dust in a mixture with air.

Zone 22 An area, in which combustible dust, as a cloud, may occur infrequently and persist for only a short period, or in which accumulations of layers of combustible dust may give rise to an explosive concentration of combustible dust in a mixture with air.

The standards and corresponding forms of protection that have been established for dust hazard protection are detailed as follows :-

IEC 61241-0	Electrical apparatus for use in the presence of combustible dust – general requirements.
IEC 61241-1	Electrical apparatus for use in the presence of combustible dust. Protection by enclosures "tD"
IEC 61241-4	Electrical apparatus for use in the presence of combustible dust. Type of Protection "pD"
IEC 61241-11	Electrical apparatus for use in the presence of combustible dust. Protection by intrinsic safety "iD"
IEC 61241-18	Electrical apparatus for use in the presence of combustible dust. Protection by encapsulation "mD"

The standard for classification of hazardous areas where dust are or may be present was previously IEC 61241-10, but is now recoded as follows :-

IEC 61241-0	Electrical apparatus for use in the presence of combustible dust. Classification of areas where combustible dusts are, or may be present.
-------------	---

The standard test methods for determining the characteristics of the dust hazard are shown as follows :-

IEC 61241-2-1	Electrical apparatus for use in the presence of combustible dust - Part 2: Test methods - Section 1: Methods for determining the minimum ignition temperatures of dust.
IEC 61241-2-2	Electrical apparatus for use in the presence of combustible dust - Part 2: Test methods - Section 2: Method for determining the electrical resistivity of dust in layers.
IEC 61241-2-3	Electrical apparatus for use in the presence of combustible dust - Part 2: Test methods - Section 3: Method for determining minimum ignition energy of dust/air mixtures.

Combustible dust can be ignited by electrical apparatus in several ways :-

- By surfaces of the apparatus that are above the minimum ignition temperature of the dust concerned. The temperature at which a type of dust ignites is a function of the properties of the dust, whether the dust is in a cloud or layer, the thickness of the layer and the geometry of the heat source.
- By arcing or sparking of electrical parts such as switches, contacts, commutators, brushes, or the like.
- By discharge of an accumulated electrostatic charge.
- By radiated energy (e.g. electromagnetic radiation).
- By mechanical sparking or frictional sparking or heating associated with the apparatus.

Selection of Equipment for Dust Hazards :-

When selecting equipment intended for use in areas where potentially explosive dust hazards may be present, and accessible to dust, the selection process would entail the review of certified equipment rated for dust hazards to a standard set of procedures. This would involve selection of the form of equipment protection, and ATEX dust group when applicable, and also identifying the permissible Ignition Temperature of the apparatus.

Dust in its deposited form has a different ignition temperature than in its stirred form.

IEC 61241-2-1 specifies the method of determining the ignition temperatures identified as procedure A for deposits, or layers, and procedure B for clouds.

The permissible Ignition Temperature of the apparatus would be determined by firstly identifying the ignition temperature of the dust as a deposit, and then as a cloud :-

Smouldering temperature based upon 'Deposit' – Method A according to IEC 61241-2-1

Ignition temperature based upon 'Cloud' – Method B according to IEC 61241-2-1

Secondly by subtracting 75 K from the value determined using method A and by multiplying by 2/3 the value determined using method B, the two ignition temperature values for the combustible dust will be known. The lower of the two values determined in this way corresponds to the lowest permissible surface temperature of the equipment.

For example the following results may be drawn for brown coal :-

T max = Smouldering temperature -75 K e. g. brown coal 225 °C -75 °C = 150 °C or,

T max = 2/3 of the ignition temperature e. g. brown coal 2/3 * 380 °C = 254 °C,

In which case equipment should be selected that is limited to a Tmax 150 °C rating.

It should be noted that compliance with this standard will only provide the required level of safety if the electrical apparatus is operated within its rating and is installed and maintained according to the relevant codes of practice or requirements, for example in respect of protection against over currents, internal short-circuits, and other electrical faults. In particular, it is essential that the severity and duration of an internal or external fault be limited to values that can be sustained by the electrical apparatus without damage.

ATEX DIRECTIVES

European Communities ATEX Directive(s)

What is ATEX and why was it introduced ?

ATEX is the name given to a set of European Directives relating to Hazardous Area Installations (Flammable Atmospheres) that takes its name from the French "Atmosphères Explosibles", and spells out a set of Essential Health & Safety Requirements (EHSR's) and conformity assessment procedures which when followed should enable the industry to operate safely & avoid accident or incident.

ATEX is a so-called "New Approach" Directive which must be applied to equipment within its scope before being placed on the European market.

These requirements provide for a high level of protection for citizens within the EU.

There are two ATEX directives, 94/9/EC, commonly referred to as ATEX 95, and 99/92/EC, commonly referred to as ATEX 137.

Why was ATEX introduced ?

The ATEX Directive 94/9/EC (commonly referred to as ATEX 95) of March 23rd 1994, is a directive adopted by the European Union (EU), under its "new approach" strategy, primarily to facilitate free trade in the EU by aligning the technical and legal requirements in the EC member states for products intended to be used in potentially explosive atmospheres.

This requires manufacturers to adhere strictly to the latest European Normatives (EN Standards) in respect of design, construction & certification, with the intention of removing national barriers and making a level playing field for trade.

This new approach supersedes the "Old Approach" Directive, the Potentially Explosive Atmospheres Directive, 76/117/EEC, along with 79/196/EEC and all of its amendments.

Examples of New Approach Directives (<http://www.newapproach.org/>)

New Approach directives (directives providing application of for the CE mark) •			
Directive	Number of Directive / Amendment	Date of Application	End of Transition Period
Low voltage equipment	73/23/EEC	19/08/1974	01/01/1997
	93/68/EEC	01/01/1995	01/01/1997
Simple pressure vessels	87/404/EEC	01/07/1990	01/07/1992
	90/488/EEC	01/07/1991	
	93/68/EEC	01/01/1995	01/01/1997
Toys	88/378/EEC	01/01/1990	
	93/68/EEC	01/01/1995	01/01/1997
Construction products	89/106/EEC	27/06/1991	
	93/68/EEC	01/01/1995	01/01/1997
Electromagnetic compatibility	89/336/EEC	01/01/1992	31/12/1995
	92/31/EEC	28/10/1992	
	93/68/EEC	01/01/1995	01/01/1997
Machinery	98/13/EC	06/11/1992	
	98/37/EC	01/01/1993	31/12/1994
		01/01/1995	31/12/1996
Personal protective equipment		01/01/1995	01/01/1997
	89/686/EEC	01/07/1992	30/06/1995
	93/68/EEC	01/01/1995	01/01/1997
	93/95/EEC	29/01/1994	
Non-automatic weighing instruments	96/58/EC	01/01/1997	
	90/384/EEC	01/01/1993	31/12/2002
Gas appliances	93/68/EEC	01/01/1995	01/01/1997
	90/396/EEC	01/01/1992	31/12/1995
Hot water boilers	93/68/EEC	01/01/1995	01/01/1997
	92/42/EEC	01/01/1994	31/12/1997
Civil explosives	93/15/EEC	01/01/1995	31/12/2002
Potentially explosive atmospheres	94/9/EC	01/03/1996	30/06/2003
Lifts	95/16/EC	01/07/1997	30/06/1999
Refrigeration appliances	96/57/EC	03/09/1999	
Pressure equipment	97/23/EC	9/11/1999	29/05/2002

The European Commission Blue Guide is a useful reference document, which is found at the following url :- http://europa.eu.int/comm/enterprise/newapproach/legislation/guide/document/1999_1282_en.pdf

When did the ATEX Directive take effect ?

The ATEX 95 Directive took effect on a voluntary basis on March 1st, 1996, and following a period of transition, became effective on a compulsory basis from July 1st, 2003.

All products or equipment intended for use in potentially explosive atmospheres that were not yet placed on the market in the EU had to comply with the ATEX 95 Directive, and the latest technological know how, or state of the art.

“Placing on the market” is considered to take place when finished product or equipment enters into the supply chain within the EC. This is accepted as being placed in the stock of the end user, the distributor or indeed the manufacturer, provided that his premises where the products or equipment are being placed is within EC boundaries.

Products that were not ATEX compliant and which are already in the distribution chain prior to July 1st, 2003 were considered to be not affected.

Products Covered by the ATEX Directive

The ATEX Directive 94/9/EC (ATEX 95) covers “Equipment” and “Protective Systems” which may be used in potentially explosive atmospheres created by the presence of flammable gases, vapours, mists or dust.

“Equipment” is any item, which can be either electrical or non-electrical, and which contains or constitutes a potential ignition source and which requires special measures to be incorporated in its design and/or its installation in order to prevent the ignition source from initiating an explosion in the surrounding atmospheres.

“Protective Systems” are items which prevent an explosion that has been initiated from spreading or causing damage. They included flame arrestors, quenching systems, pressure relief panels and fast-acting shut-off valves.

A wide range of products fall under the definition of equipment, including electric motors, compressors, diesel engines, lighting fittings, control and communication devices and monitoring and detection equipment.

Also included in the term “equipment” are safety or control devices installed outside of the hazardous area but having an explosion protection function. These must also comply with the ATEX Directive under the following conditions:

If the equipment is a safety device, controller or regulatory device; and if the equipment is required for the safe function of equipment or protective systems with respect to the risk of explosion.

Products Not Covered by the ATEX Directive

The directive excludes the following types of products:

- Medical devices,
- Products for use in the presence of explosives,
- Products for domestic use,
- Personal protective equipment,
- Sea-going vessels and mobile off-shore units,
- Means of transport, except vehicles for use in potentially explosive atmospheres,
- Military equipment.



Meeting the ATEX 94/9/EC Directive

The ATEX Directive specifies a number of Conformity Assessment Procedures and the circumstances when they must be used. The procedures are:

- EC type examination,
- Quality assurance,
- Verification modules,
- Internal Control of Production.

Equipment Category	Definition	Protection Method	Existing equivalent IEC Designation
M1	Equipment intended for mining use and is required to remain functional in the presence of an explosive mixture	2 levels of protection, or safe under 2 independent faults	Group I
M2	Equipment intended for mining use but is intended to be de-energised in the event of an explosive atmosphere.	1 level of protection based on normal operation	Group I
1G	Non-mining equipment for use in Zone 0	2 levels of protection, or safe under 2 independent faults	Group II, Zone 0 – gas
1D	Non-mining equipment for use in Zone 0		Group II, Zone 20 – dust
2G	Non-mining equipment for use in Zone 1	1 level of protection based on frequent disturbances; or equipment faults	Group II, Zone 1 – gas
2D	Non-mining equipment for use in Zone 1		Group II, Zone 21 – dust
3G	Non-mining equipment for use in Zone 2	1 level of protection based on normal operation	Group II, Zone 2 – gas
3D	Non-mining equipment for use in Zone 2		Group II, Zone 22 - dust

CE Marking and the ATEX Directive

Certified Explosion protected products and equipment intended for use in Hazardous Areas within the EC, and which must carry the CE Mark, can only show this mark if they comply strictly with the ATEX 95 directive, and this means that the latest technical knowledge as contained in the applicable European Standards has been taken into account. When product or equipment is certified in accordance with the ATEX directive, the product marking and documentation related to this would in addition bear the Ex symbol signifying that it has been tested against applicable European Standards and that it meets the Essential Health & Safety Requirements of the Directive.



CE = CENELEC COMPLIANCE

Indicates compliance with all relevant European Standards and Directives

ATEX 94/9/EC Responsibilities

	Electrical Equipment				
	Category M1	Category M2	Category 1	Category 2	Category 3
Verification Responsibilities					
Technical File Held By	Notified Body	Notified Body	Notified Body	Notified Body	Manufacturer
EHSR of ATEX 95	Notified Body	Notified Body	Notified Body	Notified Body	Manufacturer
EC Type Examination	Notified Body	Notified Body	Notified Body	Notified Body	
Product Verification	Notified Body		Notified Body		
Conformity to Type		Manufacturer or Notified Body		Manufacturer or Notified Body	
Unit Verification (Option)	Manufacturer	Manufacturer	Manufacturer	Manufacturer	Manufacturer
Quality Assurance	Notified Body	Notified Body	Notified Body	Notified Body	
Internal Control of Production	Manufacturer	Manufacturer	Manufacturer	Manufacturer	Manufacturer

The manufacturer of the equipment, when placing products or equipment on the market should provide a Declaration of Conformity confirming that his products are identical to the samples originally type tested by the Ex Notified Body, and that they meet the Essential Health & Safety Requirements of the Directive 94/9/EC. This should include compliance with the latest technical knowledge, or state of the art arising out of substantive change in the standards affecting that product or equipment, which may have occurred after the original certificate was granted. For further information on the subject Chapter 10 of the ATEX 94/9/EC Directive Guidelines can be consulted.

See <http://ec.europa.eu/enterprise/atex/guide/chapten.htm>

ATEX 137 Directive (1999/92/EC)

Operators and Contractors must comply with regulations laid down to ensure the Safety of Workers and follow Installation Codes of Practice that are designed to reduce risk. Under UK law, the Health & Safety at Work Act makes employers responsible for ensuring the health and safety of their employees and also of the public, if they are at risk from dangerous substances.

The Protection of Workers at Risk from Potentially Explosive Atmospheres Directive 1999/92/EC (ATEX 137) establishes minimum requirements to protect workers against hazards from explosive atmospheres.

It deals only with explosive atmospheres and compliance was mandatory from 1st July 2003 for new installations and from 1st July 2006 for existing installations.

Extracts from the ATEX worker protection directive (1999/92/EC) – ATEX 137

Employers are required to prepare an Explosion Protection Document that clearly demonstrates in particular:

- That explosion risks have been assessed
- That adequate measures will be taken to attain the aims of the directive
- Those places which have been classified into zones in accordance with Annex I of the directive
- Those places where minimum requirements set out in Annex II of the directive will apply
- That the workplace, and work equipment, including warning devices, are designed, operated and maintained with due regard for safety,
- That in accordance with Council directive 89/655/EEC arrangements have been made for the safe use of equipment.

The Explosion Protection Document shall be drawn up prior to the commencement of work and be revised when the workplace, work equipment or organisation of the work undergoes significant changes, extensions or conversions.

UK DSEAR Regulations 2002 & EC Chemical Agents (C.A.D.)

In the United Kingdom, the Dangerous Substances in Explosible Atmospheres Regulations (DSEAR) which came into force on December 9th 2002, requires operators, under a Statutory Instrument (S.I. 2002 Number 2776) of the UK government, to make use of the ATEX 137 and the EC Chemical Agents (CAD) 98/24/EC directives to ensure safety in the work place.

The ultimate object of the legislation is to ensure that as a minimum, the Essential Health and Safety requirements of the new approach directives are met.

Further information can be obtained from :-

- Safety Policy Directorate of the UK Health & Safety Executive - <http://www.hse.gov.uk/spd/>
- The official publication of the European Communities ATEX Directives – found at Europa – <http://europa.eu.int/comm/enterprise/atex/guide/index.htm>
- List of European Standardisation Organisations - <http://europa.eu.int/comm/enterprise/newapproach/standardization/harmstds/>
- Standards & Technical Regulations Directorate of the UK Government Department of Trade & Industry - <http://www.dti.gov.uk/strd/atex.htm>

NON ELECTRICAL EQUIPMENT

The need for non electrical apparatus to be assessed, tested, rated, labelled and certified for use in potentially explosive atmospheres was introduced for the first time as part of the implementation of the

ATEX Directives 94/9/EC & 1999/92/EC. Here is a summary of the standards that have been established against which the non electrical apparatus should be tested.

EN 13463-1:2001	Non electrical equipment for use in potentially explosive atmospheres – Basic method and requirements
EN 13463-2:2004	Non electrical equipment for use in potentially explosive atmospheres – Protection by flow restricting enclosure (symbol: fr) - The explosive atmosphere is prevented from reaching the ignition source by the tight seals of the enclosure. The seals restrict the breathing of the enclosure as internal air heats and cools through operation of the equipment.
EN 13463-3:2005	Non electrical equipment for use in potentially explosive atmospheres – Protection by flemeproof enclosure (symbol: d) - An ignition inside the equipment does not propagate the external atmosphere. This type of protection relies on closely machined joints and a robust enclosure.
prEN 13463-4	Non electrical equipment for use in potentially explosive atmospheres – Protection by inherent safety (symbol: g) - low potential energy
EN 13463-5:2003	Non electrical equipment for use in potentially explosive atmospheres – Protection by by constructional safety (symbol: c) - Ignition hazards are eliminated by the specification of the equipment.
EN 13463-6:2005	Non electrical equipment for use in potentially explosive atmospheres – Protection by control of ignition sources (symbol: b) - sources of ignition are only present in the event of a malfunction. The equipment is fitted with control equipment to detect malfunctions and prevent ignition sources arising.
prEN 13463-7	Non electrical equipment for use in potentially explosive atmospheres – Protection by pressurisation (symbol: p) - draft not yet available. In general, the enclosure is purged with a protective gas (air) and pressurised to ensure that an external atmosphere cannot re-enter the enclosure.
EN 13463-8:2003	Non electrical equipment for use in potentially explosive atmospheres – Protection by liquid immersion (symbol: k) - The enclosure has a suitable liquid to prevent the explosive atmosphere reaching the ignition source or to cool a hot surface

COMPLIANCE WITH IEC STANDARDS AND EUROPEAN NORMATIVES

EQUIPMENT FORM OF PROTECTION		CHANGING STANDARDS REFERENCES	
Protection method	Code	CENELEC STANDARD	NEW IEC BASED STANDARD
General Requirements	N/A	EN 50014 : 1997 +A1 A2	EN 60079-0 : 2006 (IEC 60079-0 : 2004 modified)
Flameproof	Ex d	EN 50018 : 2000 +A1	EN 60079-1 : 2004 (IEC 60079-1 : 2003)
Intrinsic safety	Ex i	EN 50020 : 2002	EN 60079-11 : 2006 (IEC 60079-11 : 2006)
Increased safety	Ex e	EN 50019 : 2000	EN 60079-7 : 2003 (IEC 60079-7 : 2001)
Oil Immersion	Ex o	EN 50028 : 1987	EN (IEC 60079-6 : 1995)
Encapsulation	Ex m	EN 50015 : 1998	EN 60079-18 : 2004 (IEC 60079-18 : 2004)
Pressurisation	Ex p	EN 50016 : 2002	EN 60079-2 : 2004 (IEC 60079-2 : 2001)
Sand / Quartz Filled	Ex q	EN 50017 : 1998	EN (IEC 60079-5 : 1997)
Non-Sparking	Ex nA	EN 50021 : 1999	EN 60079-15 : 2005 (IEC 60079-15 : 2005)
Enclosed Break	Ex nW		
Energy Limitation	Ex nL		
Restricted Breathing	Ex nR		
EQUIPMENT FORM OF PROTECTION NOT RECOGNISED UNDER IEC 60079 SERIES			
Simple Pressurisation	Ex nP	EN 50021 : 1999	No IEC Replacement Standard
Special Protection not covered by other recognised forms of protection	Ex s	E.H.S.R.'s of ATEX 94/9/EC Directive	No IEC Replacement Standard

Protection methods designated with 'Ex', as shown in the above tables, signifying compliance with the relevant apparatus certification standards for the given code of protection, may be approved to both European Normatives & IEC Standards.

Adoption of the "new" European standards was to be effected at National level (in each EC member country) from 2004 and the date

by which most of the old standards were to be withdrawn was 1.3.2007. Implementation of the new IEC based standards means that ATEX approved equipment is now listed as Ex d or Ex e rather than EEx d or EEx e, since the introduction of the new EN 60079 series. Consequently it is for the foreseeable future very easy to distinguish whether products comply with the latest standards or not.

APPARATUS MARKING

In order to satisfy the requirements of certification, it is necessary to include certain data marked on the main apparatus. This would normally be applied using a permanently affixed label or nameplate, and should include minimum information such as :-



- The name and address of the manufacturer,
- The Type, and Serial Number of the apparatus,
- The year the apparatus was manufactured,
- The specific marking of explosion protection, apparatus group, and category of protection as defined in the apparatus certificate, e.g.
- Details of Certification Number,
- IEC 60079-0, IEC 60079-1, IEC 61241-1 (Optional),
- Ex nR II (For Example),
- Temperature Classification,
- 0518 Quality Assurance Notified Body Identification (ATEX only),
- Gas & Dust Groups (ATEX only),
- Maximum Surface Temperature (T rating),
- Ingress Protection (IP) Rating,
- Voltage Rating – where applicable,
- Frequency Rating – where applicable,
- Current Rating (Amps) - where applicable,
- Watts Rating (Maximum Dissipated Power) – where applicable.

The following is an example of typical marking that may be applied to Group II apparatus certified under ATEX certification :-

ABC Manufacturers Limited, Old Street, New Town, Middlesex, NT7 9LB, UK

Type ABC9	CE 0518	Ex d IIC T4 Ex tD A21 IP66	II 2 GD	T 100
		SIRA 07 ATEX 9876 X		
DO NOT OPEN WHEN ENERGISED		ALLOW TO COOL FOR 20 MINUTES BEFORE OPENING		
T _{amb} -20° C to +55° C		IP 66		
VOLTAGE	FREQUENCY	WATTS	AMPS	
220 – 240 V	47 – 63 HZ	2 x 40 W	0.32 A	
SERIAL NUMBER		YEAR OF MANUFACTURE		
12345678		2007		

The following is an example of typical marking that may be applied to Group II apparatus certified under IEC Ex certification :-

ABC Manufacturers Limited, Old Street, New Town, Middlesex, NT7 9LB, UK

Type ABC9	CE 0518	Ex d IIC T4 Ex tD A21 IP66 T100		
		IEC Ex SIR.07.9877 X		
DO NOT OPEN WHEN ENERGISED		ALLOW TO COOL FOR 20 MINUTES BEFORE OPENING		
T _{amb} -20° C to +55° C		IP 66		
VOLTAGE	FREQUENCY	WATTS	AMPS	
220 – 240 V	47 – 63 HZ	2 x 40 W	0.32 A	
SERIAL NUMBER		YEAR OF MANUFACTURE		
12345679		2007		

It can be seen that the main difference between the two marking methods is the way in which the dust protection identification is coded, e.g. Ex d IIC 2D under the ATEX certification system and Ex tD A21 IP66 under the IEC Ex certification system. In many cases

manufacturers of apparatus may have certified its equipment under both ATEX and IEC Ex certification systems, in which case it may be possible to combine the marking into a single certification nameplate that addresses the requirements of both.

PURPOSE OF CERTIFICATION

Before products, equipment, or protective systems can be selected for installation in a hazardous area they should first be certified as being suitable for that application. A Certificate of Conformity for equipment intended for use in Explosive Atmospheres is evidence that the product, equipment or protective system conforms and has been tested to a relevant standard. The Certificate of Conformity will clearly show the standards to which the test were carried out, and which edition of the standard was used, and it should also provide a schedule describing the apparatus and any variations or modifications that have been approved. The Certificate of Conformity

should endorse the type of equipment proposed to be used as being safe for its intended use, with any Special Conditions for Safe Use, if applicable, clearly spelled out within the document.

It should be noted that the certificate alone does not make an installation safe, and there is an obligation on the part of the installation contractor and / owner to ensure that the apparatus is installed correctly, in a competent manner, and in accordance with the manufacturers instructions, taking into account any special conditions for safe use that may exist.

IEC EX CERTIFICATION SCHEME

IEC Ex 02 International Certification Scheme

In addition to the preparation of International Standards, the IEC facilitates the operation of Conformity Assessment Schemes. One such scheme is the IEC Ex 02 Scheme.

The IECEx 02 scheme is a single global certification scheme based on the International Electrotechnical Commission's international standards.

The IEC Ex Scheme comprises the following two Global Certification Programs:

1. The IEC Ex Certified Equipment Program
2. The IEC Ex Certified Service Facilities Program

This IEC Ex Program is an International Certification Scheme covering product that meets the requirements of International Standards prepared by TC 31 e.g. IEC 60079 series.

Scheme Objective

The objective of the IEC Ex Scheme is to facilitate international trade in equipment and services for use in explosive atmospheres, whilst maintaining the required level of safety resulting in:

- Reduced testing and certification costs to manufacturer,
- Reduced time to market,
- International confidence in the product assessment process,
- One international database listing,
- Maintaining International Confidence in equipment and services covered by IEC Ex Certification.

Similarities between IEC Ex & ATEX Approval

Under the IEC 60079 series, IEC Ex and ATEX certificates cover the approval of products and equipment to the same IEC based standards, assuming that the products and equipment have been approved to the latest standards. In some countries of the world it is considered that IEC Ex certification, which complies with the ISO 5 system, is a superior form of approval, and that ATEX is not regarded in the same light, as it involves "self certification". It is true to say that under the ATEX 94/9/EC Directive it is possible for manufacturers to have Category 3 (Zone 2) apparatus certified when the type testing was not carried out, and the corresponding test reports were not written by an independent third party Ex Notified Body. In such cases however, a third party Ex Notified Body is still required to provide the ATEX Certificate of Conformity, but the responsibility for the safety of

The IEC Ex Certified Equipment Program provides both:

a) A single International Certificate of Conformity that requires manufacturers to successfully complete:-

- Testing and assessment of samples for compliance with Standards,
- Assessment and auditing of manufacturers premises,
- On-going surveillance audits of manufacturers premises.

or

b) A "fast-track" process for countries where regulations still require the issuing of national Ex Certificates or approval. This is achieved by way of global acceptance of IEC Ex equipment Assessment and Test Reports.

Certificates issued by the IEC Ex Certified Equipment Program are issued as "Electronic Certificates" are live on the IEC Ex Website (www.iecex.com). This enables full public access for viewing and printing.

2. The IEC Ex Certified Service Facilities Program

This IEC Ex Program is an International Certification Scheme that covers the assessment and the on-site audit of organizations that provide a repair and overhaul service to the Ex industry. Like the IEC Ex Certified Equipment Program, only "Electronic Certificates" are issued via the "On-Line" system thereby giving industry full access to both the viewing and printing of certificates.

the product rests entirely with the manufacturer. Many manufacturers choose to have type tests conducted by the Ex Notified Body, so it is not possible to generalise and say that all Category 3, Zone 2 products certified under the requirements of the ATEX 94/9/EC directive are "self certified". Furthermore, this method of certification cannot be applied to Category 1 (Zone 0) or Category 2 (Zone 1) apparatus. The method of certification allowed for Zone 2 (Category 3) apparatus is not a new idea, this has been the case before the ATEX directive became a compulsory force in the EC, but because the practice was already in existence for quite some time, and without any real difficulties being experienced, this was subsequently included within the parameters of ATEX.

EQUIPMENT SELECTION PROCESS

Generally, electrical safety is ensured by the implementation of one of two considerations, i.e. that electrical apparatus be located where reasonably practicable outside hazardous areas, and that electrical apparatus be designed, installed and maintained in accordance with measures recommended for the area in which the apparatus is located.

The selection of equipment for use in hazardous areas will depend upon a number of variable factors including but not limited to the Zone of Use, the Hazard Category, the Gas Group or Combustible Dust data, the rating of equipment for the operating conditions, the Temperature Classification requirement of the equipment (determined by the T Rating of the flammable mixture), any construction material considerations including reliability against chemical attack, the Ingress Protection Rating required, the protection against possible damage from vibration, reduction in the risk of thermite sparking, the possibility of static charge formation, and perhaps several other factors related to the electrical characteristics of the installation.

In order to ensure that the preferred type of equipment is used on a plant or project, the responsible engineers may prefer to specify the apparatus by make and model or generic type. Bearing in mind that the most progressive and forward thinking manufacturers are continuously developing their products the task of specification must also be a continuous process.

Here are a few of the basic factors which may affect specification of electrical equipment for hazardous areas :-

- Clear definition of the acceptable form(s) of certification,
- Acceptable Certification Standards,
- Acceptable Gas Groups,
- Zone of Use requirement,
- Form of Protection preferred,
- Temperature Classification,
- Any environmental conditions,
- Any particular material requirements,
- Minimum Ingress Protection,
- Additional Deluge Test Certification, if required,
- Additional Marine approvals, if required,
- Minimum and Maximum Ambient Temperature rating.

Prior to selection being finalised and equipment being earmarked for purchase the relevant engineering personnel should review the availability of the preferred or specified equipment, verifying that it has the necessary hazardous area certification to meet the conditions prevailing. This review of certification should cover any special conditions for safe use that may be included in the certification documents to avoid subsequent non-conformities arising when the equipment is ready to be installed, commissioned, operated, inspected or maintained.

CABLE GLANDS FOR HAZARDOUS AREAS

Under IEC Standards (IEC 60079-0 & IEC 60079-1) three main types of cable glands exist for hazardous area applications, for either armoured or non armoured cables.

Form of Equipment Protection / Cable Type	Non-Armoured Cables	Armoured Cables
Increased Safety – Ex e (IEC 60079-7)		
Flameproof – Ex d (IEC 60079-1)		
Flameproof Compound Barrier – Ex d (IEC 60079-1)		

When it comes to Zone 2 equipment form of protection Type 'n', the picture is not so clear as it may first appear. As there are special requirements which apply to the sealing of cables entering form of protection type 'nR' (Restricted Breathing Enclosure) apparatus, it should not automatically be assumed that cable glands with Ex d or Ex e certification can be used.

IEC protection concepts Ex d, Ex e, Ex n

Cable Gland for Cables entering Ex e Apparatus

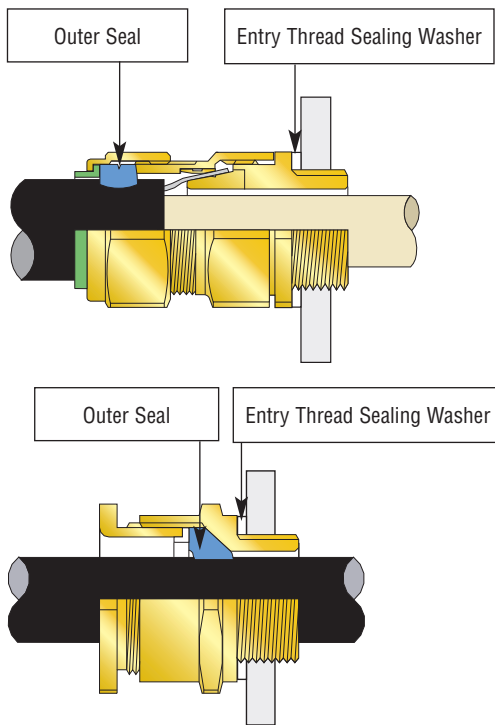

The Minimum Requirements for Ex e Cable Glands

- Impact Strength – 7 Nm,
- I.P. Rating – IP54 Gas / Vapour – IP6X Dust,
- Sealing Washer at Cable Entry Interface is Recommended,
- Single (Outer) Seal as a Minimum,
- Trend is to Use Double (Inner/Outer) Seal.

Note : Whilst the minimum Ingress Protection rating is said required to achieve Ex e certification under IEC 60079-7 is IP54, it should be considered that the cable gland is required to maintain the integrity of the equipment enclosure which is invariably higher.

It can also be noted that IEC 60079-14, section 11.3 states that threaded cable entry devices connected into threaded cable entry plates or enclosures of 6 mm or greater thickness need no additional sealing between the cable entry device and the entry plate or enclosure, providing the axis of the cable entry device is perpendicular to the external surface of the cable entry plate or enclosure.

However CMP Products recommends the use of a CMP Entry Thread Sealing Washer, which when installed at the cable entry interface, between the equipment enclosure and the cable entry device offers I.P. protection in excess of IP66. These components have been independently 3rd party tested in Ingress Protection tests to IEC 60529.

Cable Gland for Armoured Cables entering Ex d Apparatus

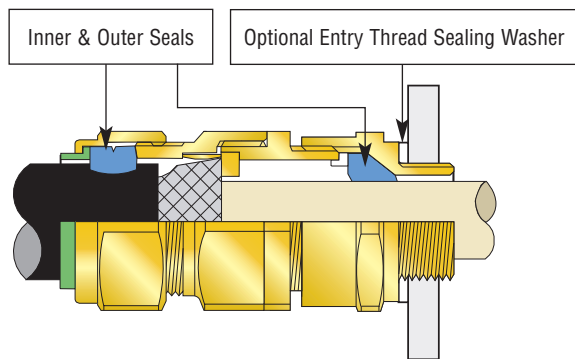

The Minimum Requirements for Ex d Cable Glands

- Screwed Entry Threads Must Maintain Flameproof Path,
- Minimum 5 Full Thread Engagement With Mating Equipment,
- Inner Seal Must be Flameproof & Gas Tight,
- Trend Has Been to Use Dual Certified Ex d / Ex e,
- Limitations Of Safe Use Usually Exist,
- Users Must Also Carefully Follow IEC 60079-14.

Cable Gland for Armoured Cables entering Ex n Apparatus

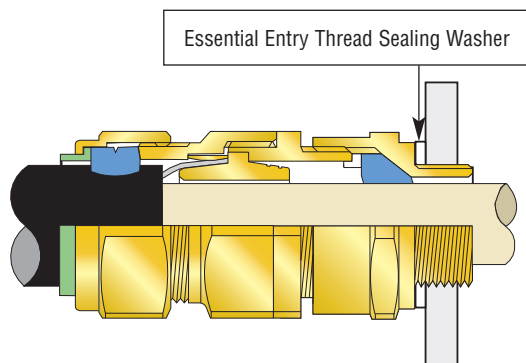

The Minimum Requirements for Ex n Cable Glands

- Cable Gland / Equipment Interface Seal is Essential,
- Restricted Breathing Enclosure Features Must be Maintained – Apparatus Maker Responsibility,
- Special Test Under IEC 60079-15 Applies For Ex nR Apparatus & Cable Entry,
- Some Flameproof Cable Glands Do Not Comply,
- Inner Seal Must be Air Tight in Two Directions.

Ex n apparatus was originally produced to early British Standards, e.g. BS 4533. Ex n cable glands were originally produced to British Standard BS 4121 (with Imperial threads) and later BS 6121 (with Metric threads), but this form of protection declined in popularity until 1990's when a new European Standard and subsequent IEC equivalent was developed and

adopted globally. Unlike Flameproof Type d cable entry devices, IEC 60079-14 says very little about the measures required to be taken by the installer to ensure compatibility when sealing cables entering Restricted Breathing enclosures.

MARKING OF CABLE GLANDS FOR HAZARDOUS AREAS

Cable Glands are classified as being equipment and would usually be marked with the same or similar information as would be applicable for main apparatus. However it should be noted that because of the nature of and relatively small size of the product certain exceptions exist. For example as cable glands are passive in respect of the operation of the electrical system they are not given a Surface Temperature rating (T Rating) during the certification process. In addition because of the amount of marking required and the size

limitations of the letters used in applying the marking it is permitted to display information such as the CE mark and year of manufacture on the packaging instead of on the product itself. CMP Cable Glands would typically be marked in the following manner to demonstrate compliance with the EU ATEX Directive 94/9/EC, and IEC Ex 02 Certification Scheme, which embraces both CENELEC and IEC standards EN 60079 & IEC 60079 :-

Example A : CMP E1FW Cable Gland

Line 1

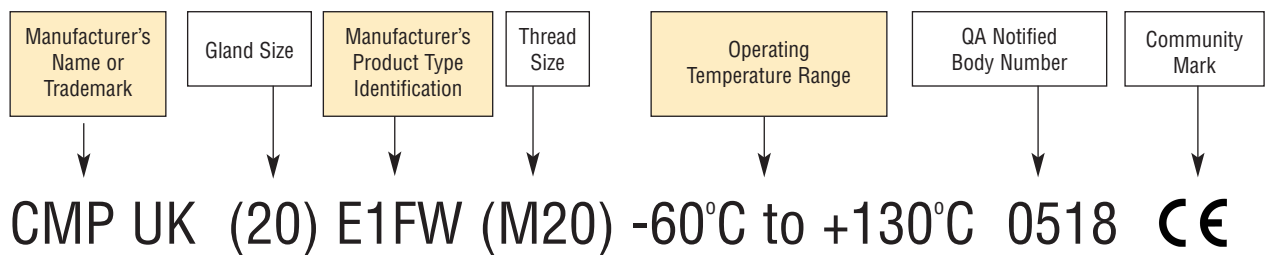

Please note that values shown in brackets above are variables that would change according to cable gland or thread size

Line 2

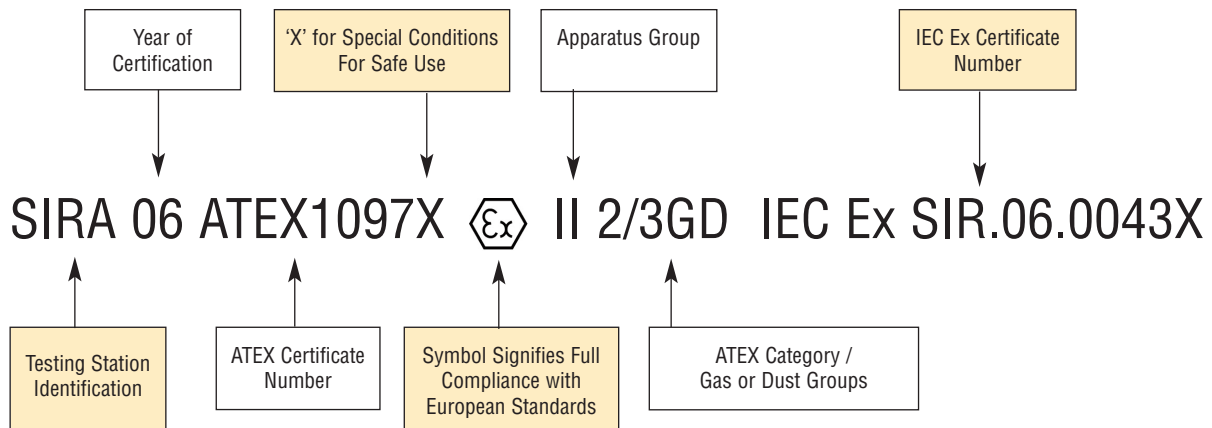

Line 3

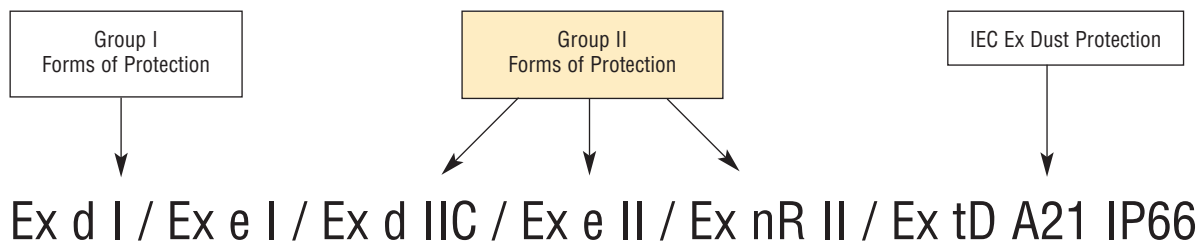

Some products in the CMP cable gland range may be required to include additional marking for example that required under UL or CSA certification, as shown opposite.

Example B : CMP T3CDS Cable Gland

Line 1

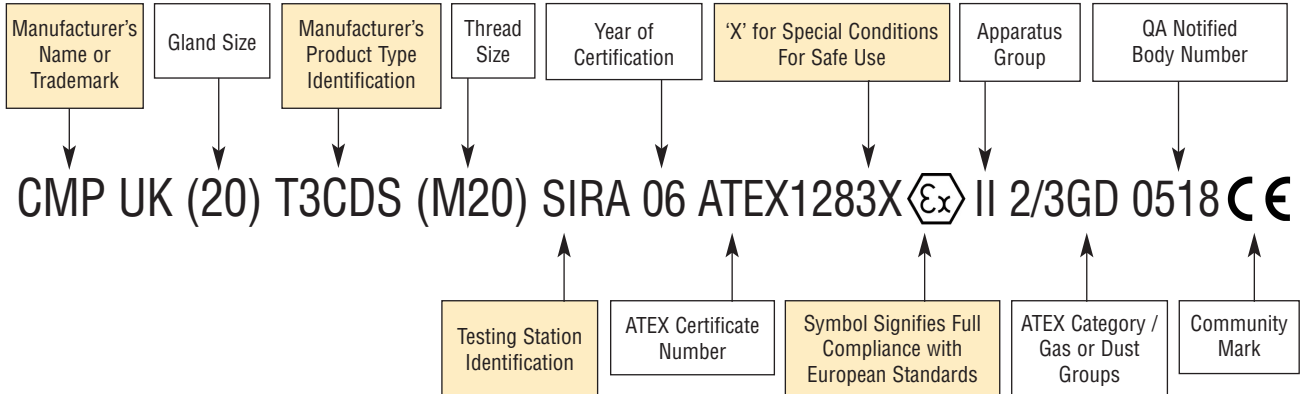

Please note that values shown in brackets above are variables that would change according to cable gland or thread size.

Line 2

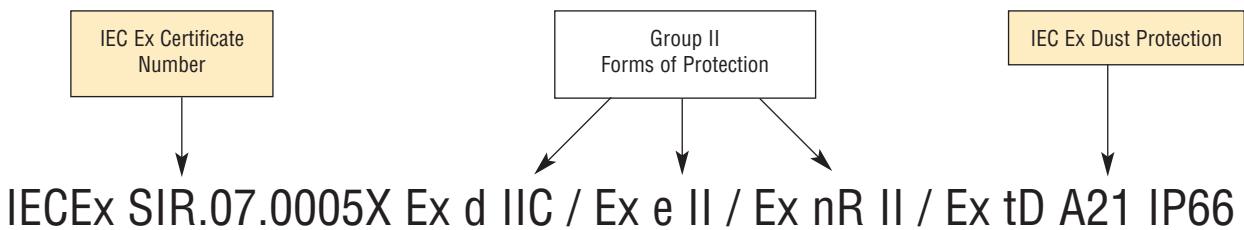

Line 3

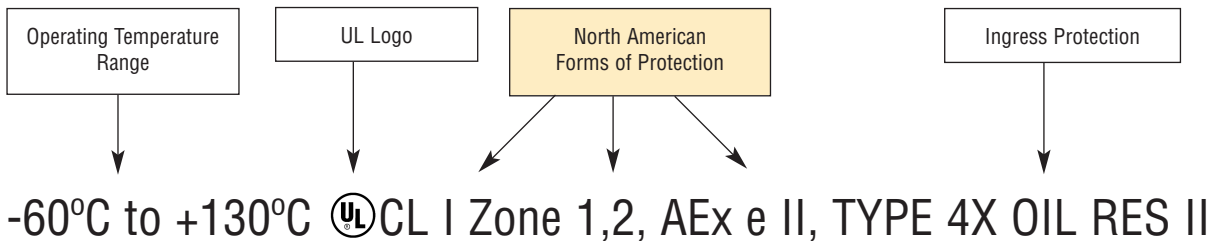

Line 4

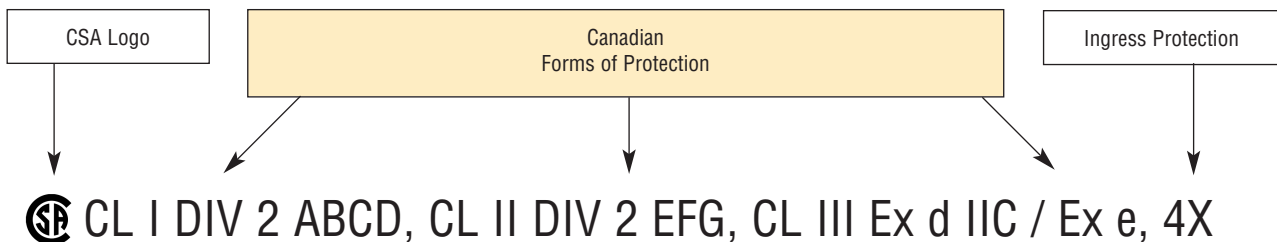

SELECTION OF CABLES INTENDED FOR USE IN HAZARDOUS AREAS

Cables come in a wide variety of shapes and sizes and new designs, e.g. those with optical fibres, are regularly being introduced.

The issue of correctly sealing these cables as they enter hazardous area electrical equipment is a worldwide problem, and not confined purely to local conditions in any one particular place.

Although there are no IEC construction standards for the cables intended for use in flammable atmospheres, according to IEC 60079-14:2002, 10.4.2(b), if a cable gland with an elastomeric flameproof sealing ring is to be used, when connecting cables to Ex d equipment enclosures, the cable should be :-

- i. Substantially compact and circular (i.e. especially the part of the cable entering the enclosure),
- ii. Have an extruded bedding (without any gaps),
- iii. Have fillers, if any are used, which are Non-Hygroscopic ?.

Effectively, the cable should be physically assessed, taking into account the protection method and configuration of the equipment, to verify its suitability, before any cable gland with an elastomeric sealing ring can be selected.

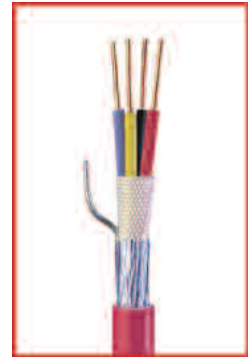

Typical IEC Cable Types

Until such times when an IEC standard for cables for use in Hazardous Areas has been developed and implemented, this applies to all types of cables used in flammable atmospheres, including :-

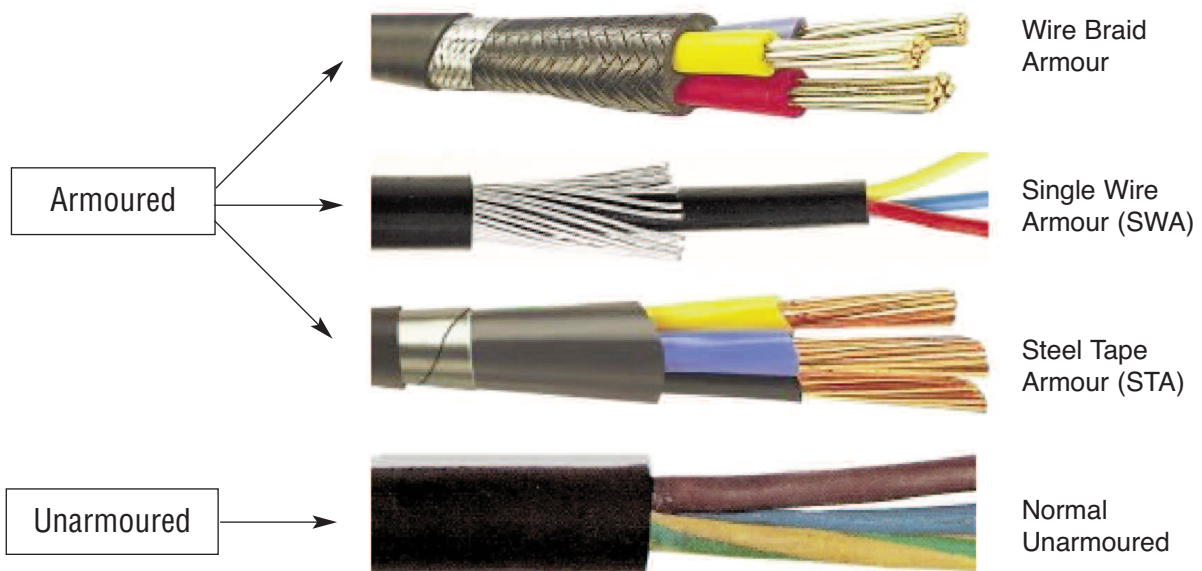

COMPATIBILITY OF EQUIPMENT, CABLE AND CABLE GLAND

Equipment & Cable Gland Compatibility

It is important to ensure that the Cable Gland is capable of maintaining the integrity of the equipment that it is engaged with.

According to IEC 60079-14:2002, 14.3.2 (under “Additional requirements for apparatus suitable only for use in Zone 2”) it states that :-

“The connection of cables shall be carried out by means of cable entry devices appropriate to the type of cable used.”

“To meet the degree of protection requirement of the terminal enclosure, it may be necessary to use cable entry devices incorporating sealing components to seal between the cable entry device and the cable. Sealing may be similarly required between the cable entry device and the enclosure. (for example by means of a sealing washer or thread sealant).”

“The sealing of restricted-breathing enclosures shall be such as to maintain the restricted-breathing properties of the enclosure.”

Interestingly some Ex d cable glands have a problem in maintaining the restricted-breathing characteristics under the prevailing test conditions.

Restricted Breathing Ex nR Equipment

Protection Method Type nR (Restricted Breathing Enclosure, from the Ex ‘n’ Family).

Usually Ex n Equipment contains components that are non – sparking. Restricted Breathing Enclosures Type nR ensure that the flammable gas is kept away from any hot surfaces and ignition capable components (i.e. arcing / sparking)

1. Light weight enclosure of metallic or non metallic construction.
2. High Ingress Protection levels must be maintained.
3. Not designed to withstand explosion.
4. Enclosure must be tightly sealed and gasketed and not allowed to breathe freely.
5. Amount of gas allowed to penetrate the enclosure is insufficient to reach the LEL, otherwise explosion could occur (see 3).

Large volumes of gas should not exist within the enclosure, & the protection method requires the gas to be kept away from the source of ignition, so as to avoid explosion & external transmission.

Extract from IEC 60079-15:2005 (3rd Edition)

Electrical Apparatus for Potentially Explosive Atmospheres – Type Protection ‘n’

Section 22 Restricted Breathing Enclosures (Page 34) - Sub-Section 22.6

Restricted Breathing enclosures without the provision for carrying out checks after installation or maintenance shall be type tested including the cable entry device. Note : The installation instructions provided with the apparatus should contain information on the selection of entry devices and cables.

Section 26 – Type Tests - Sub-Section 26.8

26.8.2 – Apparatus without provision for routine checking of restricted breathing properties.

Under constant temperature conditions, the time interval required for an internal pressure of 3 kPa (300mm Water Gauge) below atmospheric to change to 1.5 kPa (150mm Water Gauge) below atmospheric shall not be less than 3 minutes.

As the principal of Ex nR protection is required to keep sufficient quantity of the flammable mixture away from any internal ignition capable equipment and hot surfaces, this involves the use of a two way air tight and gas tight seal around the cable, and this is not possible with some (Ex d) cable gland types that include diaphragm type seals.

The important thing to remember is that not all Ex d, or Ex e, or Dual Certified (Ex d & Ex e) cable glands are able to meet the compatibility requirements for all protection forms in Zone 1 and Zone 2 hazardous areas, with particular emphasis on the Restricted Breathing enclosure concept.

CMP Products has gone to the extent of obtaining Ex nR certification for its range of double seal cable glands to EN 60079-15 / IEC 60079-15.

SELECTION PROCESS FOR HAZARDOUS AREA CABLE GLANDS ACCORDING TO IEC

Selection of Cable Glands for Flameproof Type d enclosures to IEC 60079-14

Concerning the subject of cable glands to maintain integrity of type of protection Flameproof Enclosures "d" using direct cable entry into the flameproof enclosures, special selection criterions have to be considered as defined in Section 10 of IEC Standard IEC 60079-14 "Electrical apparatus for explosive gas atmospheres Part 14: Electrical installations in hazardous areas (Other than mines)"

In order to achieve compliance with the prevailing Installation Code of Practice and in particular IEC 60079-14, it is necessary to evaluate

the function of the equipment, the cable gland, and the cable, and in order to satisfy the conditions of the applicable standards compatibility of all three with each other must be verified. Section 10 of IEC 60079-14 "Additional requirements for type of protection "d"- Flameproof enclosures" for the selection of cable glands is required to be followed, and this sets out some specific rules to ensure integrity and safe operation of the installed equipment.

Cable Entries into Ex d Enclosures

Two situations can be considered, direct cable entry and indirect cable entry

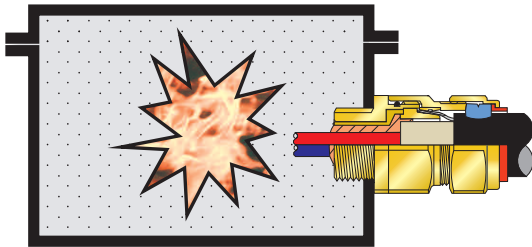

• Direct Cable Entry - Ex d

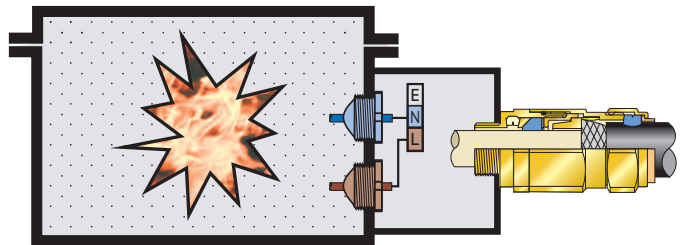

• Indirect Cable Entry - Ex d



Indirect Cable Entries into Ex d Enclosures

In the case of indirect cable entry, this may be achieved by a separate terminal chamber, where the cable entries can be found and only the (looping) cable conductors are terminated in the terminal block, where no source of ignition exists in this terminal chamber. The terminal chamber may offer Ex d or Ex e form of protection, and is separated from the main enclosure, with the internal wiring passing through line barriers or bushings before connecting to the equipment side of the terminal block. The termination and wiring of the incoming field cables would thereby not normally require the adoption of compound sealing cable glands in this case, unless there is a risk of gas migration through the interstices of the cable and the transmission of gas to the opposite end of the cable needs to be prevented. An example of this type of equipment configuration is shown in the photograph to the left.

Selection Process – According to IEC 60079 : 14

The following flow chart can only be followed as part of the IEC selection process after physical evaluation of the cable

10.4.2 Selection

The cable entry system shall comply with the following:

- a) Cable entry device in compliance with IEC 79-1 “Construction and verification test of flameproof enclosures of electrical apparatus” and particular type of cable intended for use with that device,
- b) thermoplastic, thermosetting or elastomeric cable which is substantially compact and circular, has extruded bedding and fillers, if any, are non-hygroscopic, may utilize flameproof cable entry devices, incorporating a sealing ring selected in accordance with figure 1,

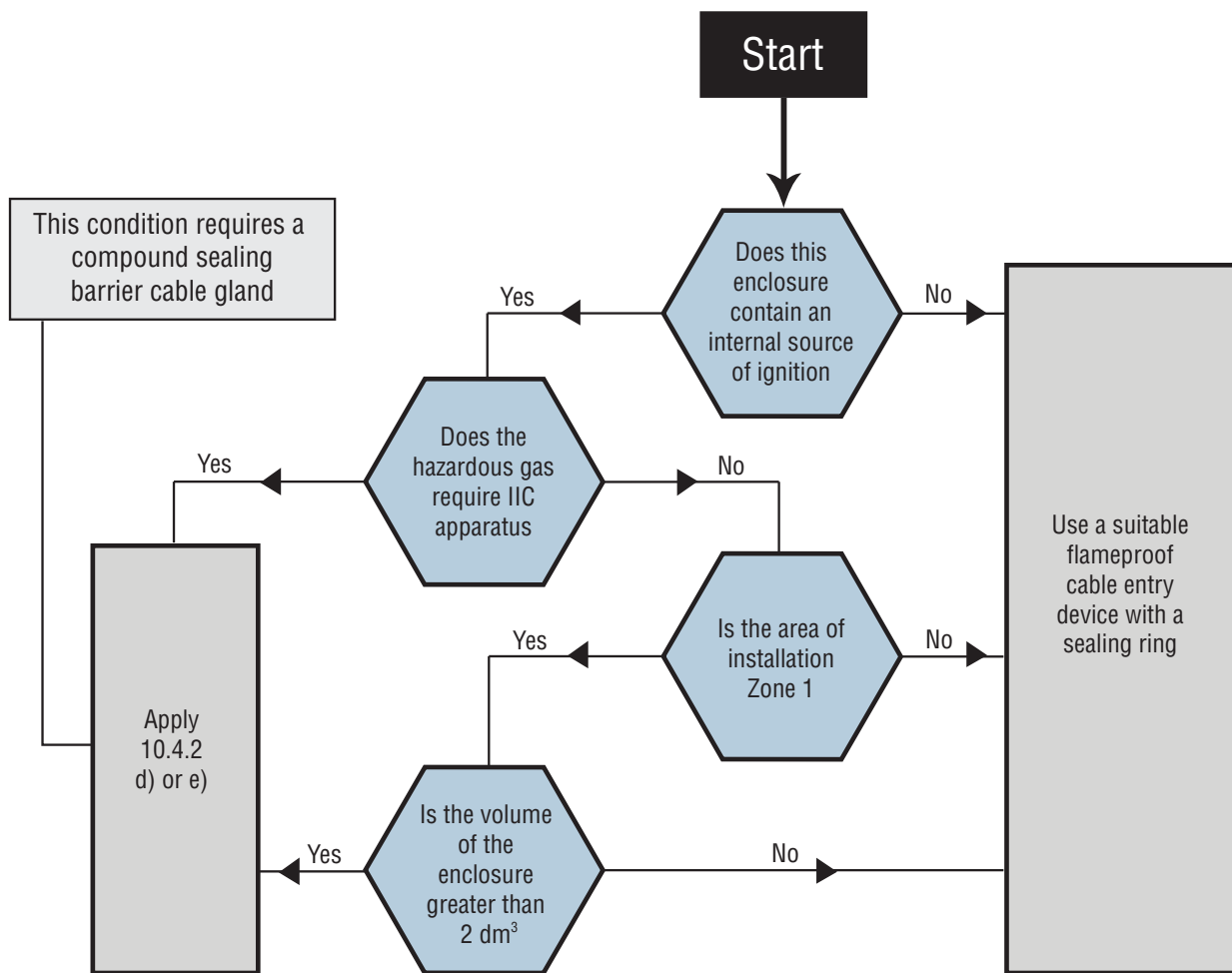

Figure 1: Selection chart for cable entry devices into flameproof enclosures for cables complying with item b) of Section 10.4.2.b.

On condition the cable gland is not certified as part of the equipment but tested and certified as a separate component and the used cable is substantially compact and circular the selection chart above taken from section 10 of EN/ IEC60079-1 can be used .

Cable Construction – Should be Round

In order to comply with IEC installation standards, cable glands using elastomeric sealing rings as a means of maintaining the Flameproof protection method can only be used if the cable selected is :-

“Substantially compact and circular with an extruded bedding, and if any fillers are used they are Non-Hygroscopic”



This is clearly not always the case with cables used in hazardous areas.

e.g., where cables run across two zones, or indeed from a hazardous area into a safe area.

But the cable must play a part in the safety of the installation, even in the case of indirect cable entry, when gas migration must be avoided

Sample IEC Cable Configurations

Which type is suitable for use with Flameproof Ex d equipment when a cable gland with an elastomeric sealing ring would be considered ?

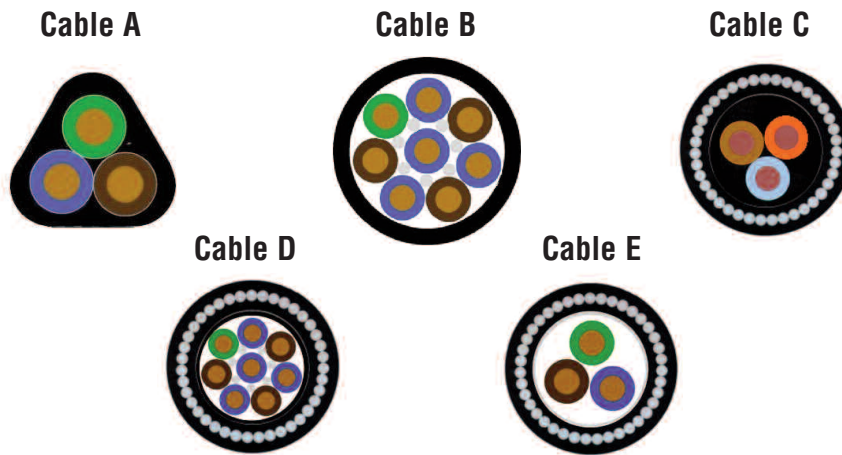

Cable A is not suitable to apply a Flameproof sealing ring as this cable is the incorrect shape, and unless the cable is round the sealing ring will not be able to make an effective seal on the cable.

has an extruded inner cable bedding and there is no gas migration path between the conductors.

Cables B, D & E are not suitable to apply a Flameproof sealing ring, as the white areas represent a gap or void in the cable whereby there is either no inner cable sheath, or extruded bedding, or suitable fillers are absent. In this case no protection to the interstices of the cable can be offered by a sealing ring.

Equally, if the cable is not adequately filled, and allows the passage of air or gas to flow along the cable length then there would be no protection to the inner part of the cable when an elastomeric sealing ring is used. In this case a compound barrier type cable gland is the only safe solution and this is needed to maintain the integrity of the equipment as explained above, and prevent gas migration from equipment to equipment, or hazardous areas to safe areas.

Cable C is the only one of the five sample cables illustrated which could be selected as correctly meeting the IEC 60079-14 criteria, as it

Ex d / Ex e IIC & Class I Division 1 - Compound Barrier Gland for Armoured Cables

e.g. CMP PX2K

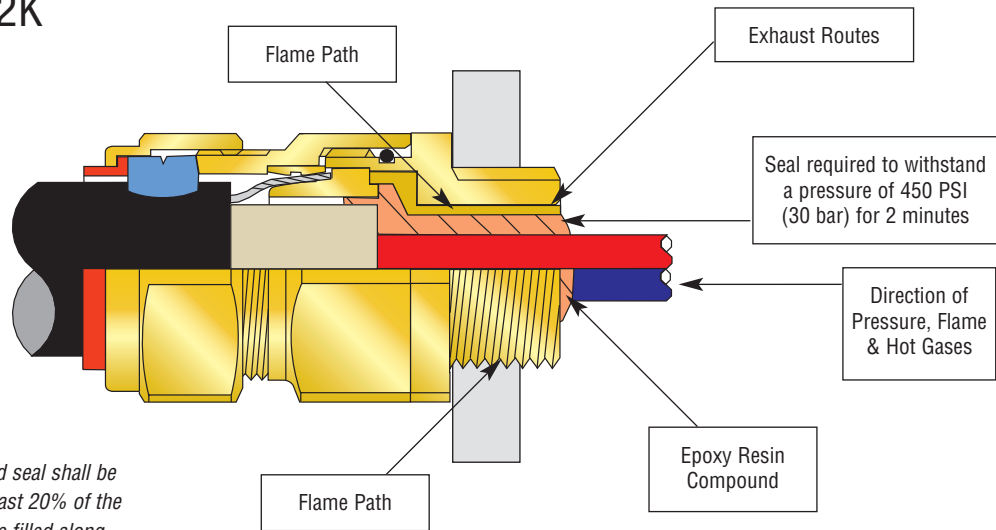

The length of the compound seal shall be 20 mm minimum, and at least 20% of the cross sectional area shall be filled along the 20 mm length of the compound seal

In conclusion it should be acknowledged that when it comes to the correct selection, deployment or installation and maintenance of cable glands in hazardous areas, referring merely to the product certification is not enough, and the guidelines laid down in the available installation code(s) of practice should be strictly observed.

The code of practice for any installation will play a vital part in the overall safety of the plant and failure to comply with it will usually lead to non-conformities and incompatibilities taking place that will inevitably compromise some aspect of safety in the ongoing operations.

COLD FLOW

Cable Glands having a combined 'one hit' flameproof sealing and armour locking function were adopted in Oil & Gas installations over prolonged periods, until several problems with this concept were identified.

Normal compression seals using only one action to tighten the armour lock and simultaneously apply the seal onto the inner cable sheath with a singular, uncontrolled action means that the seal is installed "blind" with a significant probability of excess pressure exerted on the cable.

With the increasing demand for flame retardant and fire resistant cables has come a proliferation of what are commonly described as soft bedded cables.

The need to change the use of traditional Compression Seals in hazardous area cable glands was eagerly pursued.

IEC 60079 - Cold Flow – The Challenge

Extracted from IEC 60079 – 14 (latest edition) Clause 9.1.4 states that

"The connection of cables and conduits to the electrical apparatus shall be made in accordance with the requirements of the relevant type of protection."

Care should be taken when selecting a suitable cable entry device in conjunction with certain types of cable employing materials which can exhibit 'cold flow' characteristics.

By way of example "cable entry devices not employing compression seals which act upon part(s) of the cable having cold flow characteristics" should be employed.

"Low smoke and/or fire-resistant cables usually exhibit cold flow characteristics"

"Cold flow can be more fully described as thermoplastic materials which flow when subjected to pressure at ambient temperature."

Cable Construction – The Factors

Cables installed in practice are unlike anything experienced under test conditions when mandrels are used.

With Low Smoke & Fume Cables, the cable manufacturer’s compound mix, manufacturing and curing process impact on the final shore hardness of the cable inner bedding, but these are not alone in damage from compression seals. (WRAPPING ONLY)

The impact of compression seals on the cable inner bedding can be seen even on cables without soft inner bedding, and this should be avoided at all times.

Control over the tightening of the inner seal is important, and CMP Products firmly believes that it has the answer.

Cable Construction – The Factors

1. There are no standards for cable suitability for hazardous areas.
2. Cable glands, when tested for hazardous area compliance, are subjected to hydrostatic pressure tests to prove the effect of the flameproof seal during explosion conditions, and these tests are done on polished smooth tubular steel mandrels.
3. There are no standards for the definition of soft bedded cables in terms of material composition or construction.
4. Subsequently one cable compared with another made to the “same standards” may be different in the extreme.
5. Cables installed in practice are unlike anything experienced under test conditions when considering 2. above.

RISK ASSESSMENT FACTORS AFFECTING CABLE GLAND SELECTION

In the event that a new high profile “Greenfield” project was to be developed, a major operating company may wish to go to extreme lengths in evaluating vendor prior to confirming contract award. This may incorporate a complete and comprehensive risk assessment process. The reasons for the implementation of such a demanding examination of risk can be explained by the factors detailed below :-

- Environmentally sensitive project
- Major Capital Investment
- First time operation or new Joint Venture
- Changes in technological know how
- Increase in the extremes of operating conditions.
- New Project - First Venture in New Territory
- New Challenge – everything re-evaluated
- Success of the venture under close scrutiny

The scope of the Risk Assessment Process may take into account the following :-

Commercial Evaluation

- Availability Analysis
- Reliability Analysis
- Supply Chain Management
- Ability to manage
- Reputation
- Project Quality Process
- Project management of Change Process
- Commercial assurance / warranty
- Parent Company Guarantee

Technical Evaluation

- Compliance with latest standards
- Specification, functionality, & reliability.
- Compatibility & integrity of certification
- Compatibility with specified cable type.
- Cable & gland management process.
- Package & site installation management.
- Reliability & Maintainability
- Previous track record.
- Long term performance
- Project Risk Management

Cable & Gland Management

Close co-operation between project engineers, cable, and cable gland vendors

Installation Technique & Training

- Eliminate the possibility of incorrect assembly in the cable gland design
- Adopt a simple and less scientific approach for Installation Personnel
- Project personnel to be properly trained & certificated, fully documenting this
- Training to be given to package vendors, & sub-vendors as well as main fabricators
- Follow up Inspection / Verification exercise to be implemented in conjunction with vendor.
- Vendor to act on behalf of client whilst carrying out its duties, during this process

INSTALLATION

The installation of equipment that is intended for use in explosive atmospheres should be carried out by competent personnel in line with good engineering practice. Codes of Practice, Regulations, or Standards may exist which lay down the requirements for ensuring that health and safety requirements are met by such installations. The main IEC Installation standards that are in use today for gas / vapour hazards and dust hazards are detailed below.

IEC 60079-14 : Electrical apparatus for explosive gas atmospheres – Part 14: Electrical installations in hazardous areas (other than mines)

IEC 61892-7 : Mobile and fixed offshore units - Electrical installations - Part 7: Hazardous areas

IEC 61241-14 : Electrical apparatus for use in the presence of combustible dust - Part 14: Selection and installation

Cable Gland Installation Guidelines

Installation should only be carried out by a competent person, skilled in the installation of cable glands. Care should be taken to avoid damage to entry threads when handling and installing cable glands

Cable Glands should not be installed whilst circuits are live. Similarly, following energising of the electrical circuits, cable glands should not be dismantled or opened until the circuit has been safely de-energised.

Cable Gland components are not interchangeable with those of any other cable gland manufacturer. It is important to note that components from one manufacturer's product cannot be used in that of another, and that modification of a cable gland product will invalidate the hazardous area certification.

The cable gland is not a user serviceable product and spare parts are not permitted to be supplied under the certification.

Cable Gland seals are included within the cable gland when despatched from the factory. There should be no circumstances where seals need to be removed from the cable gland. Care should be taken to avoid exposure of cable gland seals to dirt, hostile substances, e.g. solvents, and other foreign bodies.

Installation Accessories

Depending upon the specific form of protection of the main equipment it may be necessary to fit a sealing washer at the cable entry interface to maintain the appropriate Ingress Protection level of the enclosure. For Increased Safety (Ex e) equipment, or Increased Safety terminal chambers found on Ex de equipment, a sealing washer is recommended to maintain the minimum Ingress Protection rating, and should always be fitted. For other forms of protection, e.g. Flameproof Ex d apparatus, the inclusion of a sealing washer is optional.

It can be noted that IEC 60079-14, section 10.4.1 states that Flameproof (Ex d) cable entry devices may be fitted with a sealing washer between the entry device and flameproof enclosure providing that after the washer has been fitted, the applicable thread engagement is still achieved. For parallel threads, the thread engagement is normally five full threads or 8mm, whichever is the greater.

It can also be noted that IEC 60079-14, section 11.3 states that for Increased Safety Ex e enclosures, threaded cable entry devices

connected into threaded cable entry plates or enclosures of 6 mm or greater thickness need no additional sealing between the cable entry device and the entry plate or enclosure, providing the axis of the cable entry device is perpendicular to the external surface of the cable entry plate or enclosure.

CMP Sealing Washers, which are installed at the cable entry interface, between the equipment enclosure and the cable entry device (cable gland) have been 3rd party tested in Ingress Protection tests to IEC 60529. CMP Products would recommend their use in most typical outdoor situations.

Always ensure that the correct fixing accessories provided by CMP Products are used, as appropriate to secure the cable glands into the mating equipment.

In addition to Sealing Washers, CMP Products are also able to provide Locknuts, Earth Tags, and Serrated Washers which should be used as appropriate to the equipment configuration. Usually for any equipment other than Ex d apparatus, it will be necessary to use as a minimum a Locknut, and also a Serrated Washer if the enclosure of the equipment or application requires it. The addition of an Earth Tag will depend upon the earth continuity provision of the enclosures installed.

Further information on cable gland accessories can be found on pages 173 to 175 of this catalogue.

Installation Tools

Always use the correct tools, as incorrect tools will inevitably lead to mistakes, potential damage and/or personal injury. Gloves are recommended when handling and terminating cables and cable glands. Safety and personal protection should be given priority over all other considerations.

Dedicated Cable Gland spanners for each cable gland size are available from CMP Products, and these are recommended for correctly installing the product.

Adjustable spanners and wrenches are not recommended as there is a possibility of slippage that can lead to accidental injury or damage to surface finish.

Any sharp tools, instruments or knives used to cut or strip the cable sheath should be equipped with a safety blade or other safety feature consistent with the tool design and intended use.

Braid snips should be used to remove unwanted or excess cable braid. Ensure that braid snips are in good condition and effectively sharp enough to enable a first time clean cut of the cable braid without snagging.

A hacksaw, or other similar tool, should be used to cut armour wires. Hacksaw blades should be checked regularly and replaced when worn, or whenever evidence that a consistent first time clean cut is no longer possible. Note, when cutting armour wires, care should be taken to avoid cutting into the inner cable bedding or insulation beneath the armour wires.

Please refer to CMP Products in sourcing tools if required, who would be happy to assist.

INSPECTION & MAINTENANCE

The subject of Inspection and maintenance is a very important one, as in common with any non-hazardous area installations, the presence of an inspection and maintenance regime will always be effective by way of a preventative measure against the risk of incidents or accidents from arising that may otherwise go unnoticed.

The two main IEC Inspection & Maintenance standards that are in use today for gas / vapour hazards and dust hazards are detailed below.

IEC 60079 -17 : Electrical apparatus for explosive gas atmospheres - Part 17: Inspection and maintenance of electrical installations in hazardous areas (other than mines)

IEC 61241 -17 : Electrical apparatus for use in the presence of combustible dust - Part 17: Inspection and maintenance of electrical installations in hazardous areas (other than mines)

CABLE GLANDS FOR MINING APPLICATION

CMP Products has for many years designed, manufactured and supplied cable gland products for Group I mining applications, or areas including underground mines where potentially explosive atmospheres may arise. These are frequently used surface mining and quarrying applications, as well as in deep underground mines, due to the need to utilise robust solutions and for greater ease of use. In some instances the cable gland products are similar to the equivalent Group II certified versions, but they may be required to terminate special mining cables, e.g. Type 63 / Type 64 PWA cables not normally associated with other surface industries.

Flameproof cable glands with normal screwed thread connections are standard, and alternatives with integral spigot mounting flanges are also available equipped with a two bolt fixing to allow faster connect and disconnect in order to minimise machine down time.

These products are available with both ATEX and IEC Ex certification to the latest IEC 60079 series standards, and full specification and additional technical information can be found in the mining section of this catalogue.

HAZARDOUS LOCATIONS ACCORDING TO THE NATIONAL ELECTRIC CODE

In North America the standard reference documents for electrical installations are the National Electric Code (NEC) for the USA and the Canadian Electrical Code (CEC) for Canada. Electrical Equipment used in Ordinary, Wet and Hazardous (or Classified) Locations must be 'listed' by an accredited approval agency for use in the intended location. The hazardous locations include areas in which flammable, combustible or ignitable substances may occur in hazardous amounts. The NEC and CEC codes allow two methods of categorising Hazardous Locations, which are Class and Division, and Class and Zone. Electrical Apparatus approved for use in Hazardous Locations must be categorised with an Equipment Class and suitable for a specified Division and Gas Group. Their classification is made in line with the amount of combustible materials as :-

- Class I - Flammable gases, vapours or mists
- Class II - Combustible Dusts
- Class III - Ignitable Fibres and Flyings

A similar arrangement of categorising Gas Groups is used in the North American / Canadian standards as in IEC standards although the identification of Gas Groups is different. eg. :-

- Division Definitions : Division 1 or Division 2
- Equipment Classified : Class I, Division 1, A B C D

SURFACE TEMPERATURE CLASSIFICATION		
UL844	MAXIMUM TEMPERATURE (°C)	IEC 60079
T1	450	T1
T2	300	T2
T2A	280	T2
T2B	260	T2
T2C	230	T2
T2D	215	T2
T3	200	T3
T3A	180	T3
T3B	165	T3
T3C	160	T3
T4	135	T4
T4A	120	T4
T5	100	T5
T6	85	T6

GAS GROUPS		
GAS/COMPOUND	NATIONAL ELECTRIC CODE ATMOSPHERE	IEC 60079 GAS GROUP
ACETYLENE	A	IIC
CARBON DISULPHIDE	B	IIC
HYDROGEN	B	IIC
ETHYLENE OXIDE	B	IIB
HYDROGEN SULPHIDE	C	IIB
ETHYLENE	C	IIB
ACRYLONITRILE	D	IIA
INDUSTRIAL METHANE	D	IIA
PROPANE	D	IIA
ETHYL ACETATE	D	IIA

The major Approvals bodies authorised for investigation or assessment of electrical equipment include Underwriters Laboratory (UL), Factory Mutual Inc (FM) & Canadian Standards Association (CSA). In some cases, Electrical equipment may also need to meet certain Marine Standards and comply with the requirements of the US Coast Guard 14 CFR. It should be noted that the information

provided here reflects the current position but since the NEC and CEC codes are being continuously reviewed and developed, there may be other changes in process which will affect some of the rules and regulations referenced herein which are understood to be correct at the time of going to print.

CLASSIFICATION OF HAZARDOUS LOCATIONS, CLASS & DIVISION, CLASS & ZONES

NEC & CEC Hazardous Location Class & Division Definitions

Class I Locations are those in which flammable gases or vapors are, or may be, present in the air in quantities sufficient to produce explosive or ignitable mixtures.

Class I, Division 1 Location

1. Where hazardous concentrations of flammable gases or vapors exist continuously, intermittently, or periodically under normal conditions,
2. Where hazardous concentrations of such gases or vapors may exist frequently because of repair or maintenance operations or because of leakage, or
3. Where breakdown or faulty operation of equipment or processes which might release hazardous concentrations of flammable gases or vapors, might also cause Simultaneous failure of electrical equipment.

Class I, Division 2 Location

1. Where flammable volatile liquids or flammable gases are handled, processed or used, but in which the hazardous liquids, vapors, or gases will normally be confined within closed containers or closed systems from which they can escape only in case of accidental rupture or breakdown of such containers or systems, or in case of abnormal operation of equipment,
2. Where hazardous concentrations of gases or vapors are normally prevented by Positive mechanical ventilation, but which might become hazardous through failure or abnormal operation of the ventilating equipment, or
3. Which are adjacent to Class I, Division 1 locations, and to which hazardous concentrations of gases or vapors might occasionally be communicated unless such communication is prevented by adequate positive pressure ventilation from a source of clean air, and effective safeguards against ventilation failure are provided.

Class II Locations are those which are hazardous due to the presence of Combustible dust.

Class III Locations are those which are hazardous due to the presence of easily ignitable fibers or flyings, but in which such fibers or flyings are not likely to be in suspension in air in quantities sufficient to produce ignitable mixtures.

Note : It cannot be assumed that equipment suitable for Class I locations is therefore suitable for Class II and III, or that equipment suitable for Class II locations is similarly automatically suitable for Class III locations.

Equipment intended for use in Class I, Division 1 Hazardous Locations

Equipment intended for use in Class I, Division 1 hazardous locations is usually either explosion-proof, intrinsically safe, or purged / pressurized.

Definitions :

Explosion-proof apparatus: "Apparatus enclosed in a case that is capable of withstanding an explosion of a specified gas or vapor that may occur within it and of preventing the ignition of a specified gas or vapor surrounding the enclosure by sparks, flashes, or explosion of the gas or vapor within and that operates at such an external temperature that a surrounding flammable atmosphere will not be ignited thereby." Refer NFPA 70.

Intrinsically safe apparatus: "Apparatus in which all the circuits are intrinsically safe." Refer UL 913.

Intrinsically safe circuit: "A circuit in which any spark or thermal effect is incapable of causing ignition of a mixture of flammable or combustible material in air under prescribed test conditions." Refer UL 913.



Purging: "The process of supplying an enclosure with a protective gas at a sufficient flow and positive pressure to reduce the concentration of any flammable gas or vapor initially present to an acceptable level." Refer NFPA 496.

Pressurization : "The process of supplying an enclosure with a protective gas with or without continuous flow at sufficient pressure to prevent the entrance of a flammable gas or vapor, a combustible dust, or an ignitable fiber." Refer NFPA 496.

Equipment intended for use in a Class I, Division 2 Hazardous Locations

Equipment intended for use in Class I, Division 2 area is usually of the non-incendive, non-sparking, purged/pressurized, hermetically sealed, or sealed device type.

Non-incendive circuit: "A circuit in which any arc or thermal effect produced under intended operating conditions of the equipment is not capable, under the test conditions specified, of igniting the specified flammable gas- or vapor- air mixture." Refer UL 1604.

Non-incendive component: "A component having contacts for making or breaking an incendive circuit and the contacting mechanism shall be constructed so that the component is incapable of igniting the specified flammable gas- or vapor-air mixture. The housing of a non-incendive component is not intended to:

exclude the flammable atmosphere, or contain an explosion." Refer UL 1604.

Non-incendive field circuit: "A circuit that enters or leaves the equipment enclosure and that under intended operating conditions is not capable, under the test conditions specified, of igniting the specified flammable gas- or vapor-air mixture or combustible dust." Refer UL 1604.

Non-sparking apparatus: "Apparatus that has no normally arcing parts or thermal effects capable of ignition. Examples of normally arcing parts are relays, circuit breakers, servo-potentiometers adjustable resistors, switches, non-latching type connectors and motor brushes. Refer UL 1604.

Purging: "The process of supplying an enclosure with a protective gas at a sufficient flow and positive pressure to reduce the concentration of any flammable gas or vapor initially present to an acceptable level." Refer NFPA 496.

Pressurization : "The process of supplying an enclosure with a protective gas with or without continuous flow at sufficient pressure to prevent the entrance of a flammable gas or vapor, a combustible dust, or an ignitable fiber." Refer NFPA 496.

Hermetically sealed component: "A component that is sealed against entrance of an external atmosphere and in which the seal is made by fusion, such as soldering, brazing, welding, or the fusion of glass to metal." Refer UL 1604.

Sealed device: "A device that is constructed so that it cannot be opened, has no external operating mechanisms, and is sealed to restrict entry of an external atmosphere without relying on gaskets. The device may contain arcing parts or internal hot surfaces." Refer UL 1604.

Equipment intended for use in Class II, Division 1 Hazardous Locations

Equipment intended for use in Class II, Division 1 area is usually of the dust-ignition-proof, intrinsically safe, or pressurized type.

Dust-ignition-proof : "Enclosed in a manner that will exclude dusts and, where installed and protected in accordance with the NEC, will not permit arcs, sparks or heat otherwise generated or liberated inside of the enclosure to cause ignition of exterior accumulations or atmospheric suspensions of a specified dust on or in the vicinity of the enclosure." Refer NFPA 70.

Intrinsically safe apparatus: "Apparatus in which all the circuits are intrinsically safe." Refer UL 913.

Intrinsically safe circuit: "A circuit in which any spark or thermal effect is incapable of causing ignition of a mixture of flammable or combustible material in air under prescribed test conditions." Refer UL 913.

Pressurization : "The process of supplying an enclosure with a protective gas with or without continuous flow at sufficient pressure to prevent the entrance of a flammable gas or vapor, a combustible dust, or an ignitable fiber." Refer NFPA 496.

Equipment intended for use in Class II, Division 2 Hazardous Locations

Equipment intended for use in Class II, Division 2 area is usually of the dust-tight, non-incendive, non-sparking, or pressurized types.

Dust-tight: "Constructed so that dust will not enter the enclosing case under specified test conditions. An example of such conditions would be a UL Type 12 enclosure." Refer NFPA 70.

Non-incendive circuit: "A circuit in which any arc or thermal effect produced under intended operating conditions of the equipment is not capable, under the test conditions specified, of igniting the specified flammable gas- or vapor- air mixture." Refer UL 1604.

Non-incendive component: "A component having contacts for making or breaking an incendive circuit and the contacting mechanism shall be constructed so that the component is incapable of igniting the specified flammable gas- or vapor-air mixture. The housing of a non-incendive component is not intended to:

exclude the flammable atmosphere, or contain an explosion." Refer UL 1604.

Non-incendive field circuit: "A circuit that enters or leaves the equipment enclosure and that under intended operating conditions is not capable, under the test conditions specified, of igniting the specified flammable gas- or vapor-air mixture or combustible dust." Refer UL 1604.

Non-sparking apparatus: "Apparatus that has no normally arcing parts or thermal effects capable of ignition. Examples of normally arcing parts are relays, circuit breakers, servo-potentiometers adjustable resistors, switches, non-latching type connectors and motor brushes. Refer UL 1604.

Pressurization : "The process of supplying an enclosure with a protective gas with or without continuous flow at sufficient pressure to prevent the entrance of a flammable gas or vapor, a combustible dust, or an ignitable fiber." Refer NFPA 496.

Equipment intended for use in Class III, Division 1 Hazardous Locations

Equipment intended for use in Class III, Division 1 area is usually of the dust-tight or intrinsically safe type.

Dust-tight: "Constructed so that dust will not enter the enclosing case under specified test conditions. An example of such conditions would be a UL Type 12 enclosure." Refer NFPA 70.

Intrinsically safe apparatus: "Apparatus in which all the circuits are intrinsically safe." Refer UL 913.

Intrinsically safe circuit: "A circuit in which any spark or thermal effect is incapable of causing ignition of a mixture of flammable or combustible material in air under prescribed test conditions." Refer UL 913.

Equipment intended for use in Class III, Division 2 Hazardous Locations

Equipment intended for use in Class III, Division 1 area is usually of the dust-tight or intrinsically safe type.

Dust-tight: "Constructed so that dust will not enter the enclosing case under specified test conditions. An example of such conditions would be a UL Type 12 enclosure." Refer NFPA 70.

Intrinsically safe apparatus: "Apparatus in which all the circuits are intrinsically safe." Refer UL 913

NEC & CEC Hazardous Location Class & Zone Definitions

Class I, Zone 0 Locations

A Class I, Zone 0 location is a location where ignitable concentrations of flammable gases, vapors or liquids:

are present continuously; or
are present for long periods of time.

Class I, Zone 1 Locations

A Class I, Zone 1 location is a location where ignitable concentrations of flammable gases, vapors or liquids:

are likely to exist under normal operating conditions;
may exist frequently because of repair or maintenance operations or leakage; or
may exist because of equipment breakdown that simultaneously causes the equipment to become a source of ignition; or
are adjacent to a Class I, Zone 0 location from which ignitable concentrations could be communicated.

Class I, Zone 2 Locations

A Class I, Zone 2 location is a location:

where ignitable concentrations of flammable gases, vapors or liquids are not likely to occur in normal operation or, if they do occur, will exist only for a short period;
where volatile flammable liquids, or flammable gases or vapors exist, but are normally confined within closed containers where ignitable concentrations of gases, vapors, or liquids are normally prevented by positive mechanical ventilation;
adjacent to a Class I, Zone 1 location from which ignitable concentrations could be communicated.

Equipment intended for use in a Class I, Zone 0 Hazardous Locations

Equipment intended for use in a Class I, Zone 0 area is usually of the intrinsically safe, "ia," type.

Intrinsically safe apparatus: "Apparatus in which all the circuits are intrinsically safe." Refer UL 913.

Equipment intended for use in a Class I, Zone 1 Hazardous Locations

Equipment intended for use in a Class I, Zone 1 area is usually of the flameproof, purged / pressurized, oil immersed, increased safety, encapsulated or powder filled type.

Flameproof: "The enclosure of the equipment will withstand an internal explosion, and prevent passage of flame to the surrounding atmosphere. Care must be taken to maintain the length and clearance (gap) of flameproof joints in service." Refer UL 2279.

Purging: "The process of supplying an enclosure with a protective gas at a sufficient flow and positive pressure to reduce the concentration of any flammable gas or vapor initially present to an acceptable level." Refer NFPA 496.

Pressurization: "The process of supplying an enclosure with a protective gas with or without continuous flow at sufficient pressure to prevent the entrance of a flammable gas or vapor, a combustible dust, or an ignitable fiber." Refer NFPA 496.

Oil immersion: "Arcing contacts are immersed in a protective liquid."

Refer UL 2279.

Increased safety: "The equipment contains no normally arcing parts, and additional measures (such as increased spacing of wiring connections) are taken to prevent the possibility of high temperatures or sparks. A minimum Ingress Protection rating of IP 54 is required." Refer UL 2279.

Encapsulation: "Arcing contacts are completely surrounded by an encapsulating material." Refer UL 2279.

Powder filling: "Arcing contacts are surrounded by a filling material (glass or quartz powder)." Refer UL 2279.

Equipment intended for use in a Class I, Zone 2 Hazardous Locations

Equipment that is intended for use in a Class I, Zone 2 area is usually of the non-incendive, non-sparking, restricted breathing, hermetically sealed or sealed device type.

Non-incendive circuit: "A circuit in which any arc or thermal effect produced under intended operating conditions of the equipment is not capable, under the test conditions specified, of igniting the specified flammable gas- or vapor- air mixture." Refer UL 1604.

Non-incendive component: "A component having contacts for making or breaking an incendive circuit and the contacting mechanism shall be constructed so that the component is incapable of igniting the specified flammable gas- or vapor-air mixture. The housing of a non-incendive component is not intended to:

exclude the flammable atmosphere, or contain an explosion." Refer UL 1604.

Non-incendive field circuit: "A circuit that enters or leaves the equipment enclosure and that under intended operating conditions is not capable, under the test conditions specified, of igniting the specified flammable gas- or vapor-air mixture or combustible dust." Refer UL 1604.

Non-sparking apparatus: "Apparatus that has no normally arcing parts or thermal effects capable of ignition. Examples of normally arcing parts are relays, circuit breakers, servo-potentiometers adjustable resistors, switches, non-latching type connectors and motor brushes. Refer UL 1604.

Restricted breathing: "The enclosure relies on tight seals and gaskets to prevent diffusion of the explosive atmosphere into the equipment enclosure. Provision for checking that the restricted breathing properties of the enclosure are maintained is provided." Refer UL 2279.

Hermetically sealed component: "A component that is sealed against entrance of an external atmosphere and in which the seal is made by fusion, such as soldering, brazing, welding, or the fusion of glass to metal." Refer UL 1604.

Sealed device: "A device that is constructed so that it cannot be opened and is sealed to restrict entry of an external atmosphere. The device may contain arcing parts or internal hot surfaces." Refer UL 2279.

NEC Gas / Dust Definitions

Class I Groups ABCD - see Comparison Charts on the following pages.

Class II Group E – where the atmosphere contains metal dust.

Class II Group F – where the atmosphere contains carbon black, coal, or coke dust.

Class II Group G – where the atmosphere contains flour, starch, or grain dust.

Inflammable Material	IEC					NEC® / CEC		
(Gases and Vapours)	Group	Sub-Group	Zone	Protection Code	ATEX CATEGORY	Class	Division	Group
Acetylene Hydrogen	II	C	0	Ex ia	1	I	1	A
			1	Ex ia, Ex ib, Ex d, Ex e, Ex m, Ex o, or Ex q	2		2	
			2	Ex ia, Ex ib, Ex d, Ex e, Ex m, Ex o, Ex q, or Ex n	3			
			1	Ex ia, Ex ib, Ex d, Ex e, Ex m, Ex o or Ex q	2			
			2	Ex ia, Ex ib, Ex d, Ex e, Ex m, Ex o, or Ex q	3			
Propylene oxide Ethyl oxide Butadiene	II	B	0	Ex ia	1	I	1	B
			1	Ex ia, Ex ib, Ex d, Ex e, Ex m, Ex o, or Ex q	2		2	
			2	Ex ia, Ex ib, Ex d, Ex e, Ex m, Ex o, Ex q, or Ex n	3			

Inflammable Material	IEC					NEC® / CEC		
(Gases and Vapours)	Group	Sub-Group	Zone	Protection Code	ATEX CATEGORY	Class	Division	Group
Cyclopropane	II	B	0	Ex ia	1	I	1	C
Ethyl ether			1	Ex ia, Ex ib, Ex d, Ex e, Ex m, Ex o, or Ex q	2		2	
Ethylene			2	Ex ia, Ex ib, Ex d, Ex e, Ex m, Ex o, Ex q, or Ex n	3			
Acetone Benzene Butane Propane Hexane Paint solvents Natural gas	II	A	0	Ex ia	1	I	1	D
			1	Ex ia, Ex ib, Ex d, Ex e, Ex m, Ex o, or Ex q	2		2	
			2	Ex ia, Ex ib, Ex d, Ex e, Ex m, Ex o, Ex q, or Ex n	3			

UL STANDARDS INCORPORATING IEC ZONING PRINCIPALS

Article 505 of the NEC code, permits the use of the Zone method of Classified Areas.

This means that products can be approved by :-

Class, Division, & Gas Group,

e.g. Class I, Division I,A,B,C,D or

Class, Zone, & Gas Group

e.g. Class I, Zone 1 AEx d IIC

Although the code permits the approval of products for the Zone classification, in a similar way to IEC practice, this does not mean that mixing of different forms of equipment approval across zones or

divisions is acceptable. eg. products approved for Zone 1 do not necessarily meet the requirements of Division 1 which also encompasses Zone 0.

IEC Standards are also being adopted into the NEC, however, in some cases the IEC Standard is amended to suit the requirements of the NEC. e.g. IEC 60079 vs UL 60079 Hazardous Area Cable Glands. Cable glands that comply with IEC 60079 **MUST** meet the requirements of UL514B before they can be used on NEC Zone Classified Installations.

For Canada, Zone classified products are tested to IEC Standards with no national deviations.

The correlation between IEC standards adopted in North America, and the associated forms of protection is shown below :-

EQUIPMENT FORMS OF PROTECTION			CENELEC		IEC	NORTH AMERICAN STANDARDS			
Protection Method	Code of Protection	Protection Principle	ATEX CATEGORY	CENELEC Standard #	IEC Standard	Code of Protection	Permitted in Zone	UL Standards	FM Standards
Flameproof	Ex d	Contains the explosion and quenches the flame	2	EN 50018	IEC 60079-1	AEx d	1 or 2	UL 60079-1	FM3600 (ISA 12.22.01*)
Intrinsic Safety	Ex ia	Limit energy of sparks, limits the temperature	1	EN 50020	IEC 60079-11	AEx ia	0, 1, 2	UL 60079-11	FM3610 (ISA 12.12.01)
	Ex b	Limit energy of sparks, limits the temperature	2	EN 50039		AEx ib	1 or 2	UL 60079-7	FM3600 (ISA 12.16.01)
Increased Safety	Ex e	No arcs, sparks or hot surfaces	2	EN 50019	IEC 60079-7	AEx e	1 or 2	UL 60079-7	FM3600 (ISA 12.16.01*)
Encapsulated	Ex m	Keep the flammable gas away from any hot surfaces and ignition capable equipment	2	EN 50028	IEC 60079-18	AEx m	1 or 2	UL 60079-18	FM3600 (ISA 12.23.01*)
Immersed in oil	Ex o		2	EN 50015	IEC 60079-6	AEx o	1 or 2	UL 60079-6	FM3600 (ISA 12.16.01*)
Pressurised	Ex p		2	EN 50016	IEC 60079-2	Ex p	1 or 2	NFPA 496	FM3620
Quartz/Sand Filled	Ex q	Contains the explosion and quenches the flame	2	EN 50017	IEC 60079-5	Ex p	1 or 2	UL 60079-5	FM3600 (ISA 12.25.01)
Non-Sparking	Ex nA	No arcs, sparks or hot surfaces	3	EN 50021	IEC 60079-15	AEx nA	2	UL 60079-15	FM3600 (ISA 12.12.02)
Enclosed Break	Ex nC	Contains the explosion and quenches the flame				AEx nC			
Energy Limitation	Ex nL	Limits energy of sparks, limits the temperature				AEx nL			
Restricted Breathing	Ex nR					AEx nR			
Note: CENELEC Standards # may be withdrawn since EN60079 replaced EN500 series but are included for cross comparison or references purposes only						Note: Items with * also required to comply with ISA 12.00.01			

There is a similarity if not a direct equivalent between current IEC and North American Codes of Protection and Area Classification. It is envisaged any differences will be eliminated with the developing acceptance of IEC Standards in North America and vice versa. Here is a simple representative cross relationship between North American and IEC classifications :-

EQUIVALENT ZONE / DIVISION	
NEC	IEC
Division I	Zone 0
	Zone 1
Division II	Zone 2

NEC / CEC Division 1 covers both the IEC Zones 0 & Zone 1. Therefore, whilst Division 1 approved apparatus may be permitted in Zone 0 & Zone 1 areas the opposite cannot be assumed. For example Flameproof Ex d equipment certified under IEC rules is not automatically suitable for NEC / CEC Division 1 areas.

Accepting that Flameproof is not Explosion Proof and vice versa is very important, and whilst some confusion frequently occurs between both the terminology and understanding of the principles involved, the two concepts follow distinctly different testing and installation standards. For this reason alone great care should be taken when indulging in selection and installation from differing codes of practice.

IEC / NEC-CEC Deployment Comparison

Mixing of Codes is Usually Not Permitted, and this equally applies to cable glands or cable connectors.

Here is a comparison of the testing methods adopted for Ex d IIC Cable Glands to IEC 60079-1 & Class I Division 1 ABCD (NEC) Explosion Proof Cable Connectors to UL 2225 intended for use in hazardous locations, specifically for use with Ex d IIC (IEC) & Class I Division 1 (NEC or CEC) Explosion Proof apparatus.

CABLE ENTRY DEVICES - PRODUCT CERTIFICATION TESTS		
Protection method	Ex d	Explosion Proof
STANDARD	IEC 60079-1	UL2225, CSA 22.2
HYDROSTATIC PRESSURE TEST AT	450 PSI FOR 2 MINUTES	UP TO 2000 PSI FOR 2 MINUTES
ENCLOSURE TYPE / SIZE USED FOR EXPLOSION TESTING	NOT APPLICABLE	EXPLOSION PROOF 29 LITRES ENCLOSURE VOLUME

A compound barrier type (seal type) cable gland must always be used, under the NEC / CEC wiring code rules, for any Class I Division 1 or Division 2 explosion proof equipment installed in hazardous locations.

NORTH AMERICAN INSTALLATION & WIRING CODE RULES

Historically, the NEC / CEC wiring, installation and protection methods are based around a conduit system where seals are required at the point of entry to equipment required to be explosionproof. Although still widely used, conduit systems are being replaced with flexible armored and non-armored cables, with suitable cable glands providing the required sealing protection. When conduits are to be terminated into enclosures with Non-Threaded entries, a 'hub' is required to provide grounding and ingress protection. This practice is necessary for conduit entries but can greatly reduce the available terminating space on enclosures and can add significant cost to the installation. By using

cable and cable glands, simple accessories such as, entry thread seals, serrated washers and locknuts, can be used to produce the same grounding and ingress protection levels provided by 'hubs', thus reducing installation time, space utilisation and cost. The CMP cable gland product series has been tested in this method to UL514B, Nema 4, and IEC 60529 to IP66, IP67 & IP68. The illustration below shows an example of a CMP cable gland installed in a clearance hole using standard accessories which delivers a highly cost effective solution in the sealing of cable entries when the enclosure is not required to be explosion-proof.

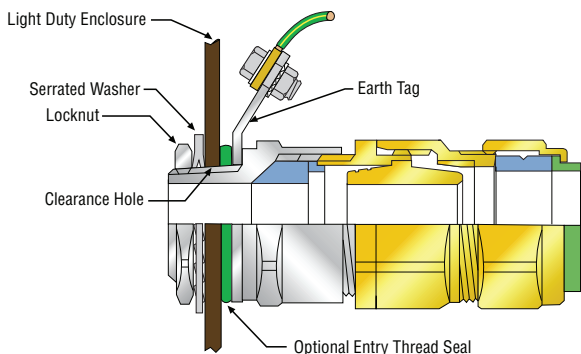

Taper threaded gland through clearance hole

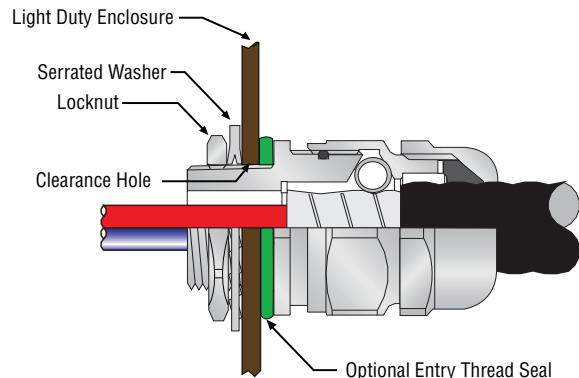

Taper threaded gland through clearance hole

Cable Wiring Methods

The use of flexible cables in North America has provided industry with a wide choice of wiring methods. However, there are differences between the NEC and CEC for cables suitable for use in Hazardous areas and extreme care should be taken during the selection process. *i.e. A cable type may be acceptable for use in Class I Division 1 in Canada, but not in the USA.*

It is essential that the wiring method chosen is permitted for use within the area classification for the relevant code being utilized.

Cable Wiring Methods - Class I, Division 1 & Zone 1

Complete lists of suitable cable types for use in hazardous areas can be found by consulting the current NEC and CEC handbooks. Additional information for common cable types approved for offshore installations can be found by consulting section 43 of IEEE Standard 45 and API RPI 14F & 14FZ.

As a general rule, cables for use in Class I Division 1 and Zone 1 areas must be mechanically protected by armor. *e.g. MC-HL and Wire Braid Armor (offshore) cables. In Canada, Interlocked armor can be also be used. e.g. Teck 90*

Cable Seals, Class I Division 1 & Zone 1

Where cables enter Class I Division 1 or Zone 1 AEx d enclosures, the cable must be sealed at the point of entry with an approved device to UL 2225 or CSA 22.2, Class I Division 1 or Zone 1 AEx d, where applicable. The sealing fitting or 'Barrier' gland must prevent the passage of gas or vapours through the gland by providing a compound barrier seal around each individual insulated conductor. *e.g. CMP TMCX or PX2KX cable connectors*

NEC 2005

Article 501.15 (E) (1) Terminations. Cables entering enclosures that are required to be explosionproof shall be sealed at the point of entrance. The seal shall comply with 501.15(B)(1)

NEC 2005

Article 501.16 (C) (2) Cable Seals. (a) Explosionproof and Flameproof Enclosures. Cables entering enclosures required to be flameproof or

explosionproof shall be sealed at the point of entrance. The seal shall comply with 505.16(D).

Note; A sealing device certified for Class I Division 1 may be used in Class I Zone 1 AEx d equipment. However, a sealing device certified ONLY for Class I Zone 1 AEx d CANNOT be used in Class I Division 1 equipment. See 501-5(d) of the NEC for further information

Cable Wiring Methods - Class I, Division 2 & Zone 2

Complete lists of suitable cable types for use in hazardous areas can be found by consulting the current NEC and CEC handbooks. Additional information for common cable types approved for offshore installations can be found by consulting section 43 of IEEE Standard 45 and API RPI 14F & 14FZ.

As a general rule, cables permitted and listed for use in Class I Division 1 and Zone 1, and listed non-armored cables can be used in Class I Division 2 and Zone 2 hazardous locations.

e.g. Type TC (Tray Cable), Interlocked Armor cables

Cable Seals, Class I Division 2 & Zone 2

Where cables enter Class I Division 2 enclosures, the cable must be sealed if the enclosure contains any arcing or sparking devices or if the enclosure is explosion proof. In such cases a sealing fitting or Barrier gland to UL 2225 or CSA 22.2, Class I Division 1 or Division 2 must be used. Where the enclosure does not contain any arcing or sparking devices and the enclosure is NOT explosion proof, a cable is not required to be sealed at the point of entry. In such cases a listed cable gland or cable connector without compound sealing function may be used. *e.g. CMP TMC, T3CDS or C2KX cable connectors.*

Similarly for Class I Zone 1 & Zone 2 AEx e enclosures (Increased Safety), a non sealing fitting approved for use in this application can be used. *e.g. CMP TMC, T3CDS or C2KX cable connectors.*

Note : Non 'Sealing' type glands are restricted to Division 2 & Zone 2 equipment that does not contain an ignition source or to Zone 1 AEx e equipment. If the enclosure is required to be explosion proof, a Sealing fitting must be used.

OVERVIEW OF CABLES PERMITTED IN HAZARDOUS LOCATIONS

Selection of Cable and Cable Connectors for Hazardous Locations.

The NEC & CEC codes require that any cable for use in a Hazardous Location must firstly be permitted in the hazardous area, and secondly be tested and approved for the application

Hazardous Location / Cable Type	Class I Division 1	Class I Division 2
NON-ARMORED TRAY CABLE	NOT PERMITTED	PERMITTED
POWER LIMITED TRAY CABLE WITH SERVED WIRE ARMOR	NOT PERMITTED	PERMITTED
IEEE 45 MARINE SHIPBOARD CABLE	PERMITTED (OFFSHORE INSTALLATIONS)	PERMITTED (OFFSHORE INSTALLATIONS)
MC-HL, ITC-HL	PERMITTED	PERMITTED
INTERLOCKED MC ARMOR & TECK	NOT PERMITTED (USA) PERMITTED (CANADA)	PERMITTED

Hazardous Location / Cable Type	Class I Zone 1	Class I Zone 2
NON-ARMORED TRAY CABLE	NOT PERMITTED	PERMITTED
POWER LIMITED TRAY CABLE WITH SERVED WIRE ARMOR	NOT PERMITTED	PERMITTED
IEEE 45 MARINE SHIPBOARD CABLE	PERMITTED (OFFSHORE INSTALLATIONS)	PERMITTED (OFFSHORE INSTALLATIONS)
MC-HL, ITC-HL	PERMITTED	PERMITTED
INTERLOCKED MC ARMOR & TECK	NOT PERMITTED (USA) PERMITTED (CANADA)	PERMITTED

Under NEC & CEC wiring code rules the use of IEC certified product is not automatically permitted under the Zone Classification Methods. Globally there are now three methods of selection and / or application of cable entry devices, and these can be explained as follows :-

i. IEC – Zone System

- Explosion Protected Ex d, Ex e, etc....

ii. NEC / CEC – Class & Division System

- Explosion Proof

iii. NEC / CEC – Class & Zone System

- Explosion Protected AEx d, AEx e, Ex d, Ex e, etc...

For Example :-

CABLE CONNECTOR TYPE / APPROVED CABLE TYPE	IEC (ZONE 1)	NEC CLASS / DIVISIONS	CEC CLASS / DIVISIONS	NEC CLASS / ZONES	CEC CLASS / ZONES
A2F (Non-Sealing Type for Non-Armored cables)	Ex d IIC & Ex e II	NOT PERMITTED (*)	NOT PERMITTED	Class I Zone 1 AEx e	Class I Zone 1 Ex d
Triton CDS (Non-Sealing Type for Braid & SWA Armored Cables)	Ex d IIC & Ex e II	NOT PERMITTED (*)	Class I Division 2, ABCD (#)	Class I Zone 1 AEx e	Class I Zone 1 Ex d
PX2K (Seal Type for Braid & SWA Armored Cables)	Ex d IIC & Ex e II	Class I Division 1	Class I Division 1, ABCD	Class I Zone 1 AEx d	Class I Zone 1 Ex d
PXSS2K (Seal Type for Non-Armored Cables)	Ex d IIC & Ex e II	Class I Division 2	Class I Division 2, ABCD	Class I Zone 2 AEx d	Class I Zone 2 Ex d
PXSS2K (Seal Type for Extra-Hard Usage Cord)	Ex d IIC & Ex e II	Class I Division 2, ABCD	Class I Division 2, ABCD	Class I Zone 1 AEx d	Class I Zone 1 Ex d

Notes : (*) Under NEC wiring rules these products may be used in Division 2 in conjunction with terminal enclosures which do not incorporate arcing or sparking devices, i.e. when there is no internal source of ignition in the enclosure.
 (#) Under CEC wiring rules these products should not be interfaced with an explosion proof enclosure containing arcing and sparking devices, unless installed in conjunction with an approved explosion proof sealing fitting.

For any Explosion proof equipment installed in Class I Division 1 & Division 2 Hazardous Locations, or AEx d equipment installed in Class I Zone 1 or Class I Zone 2 hazardous areas, a compound barrier type (seal type) cable gland must always be used under the NEC – CEC wiring code rules.

Typical Class I Division 1 & Division 2 Sealing Methods

MC-HL Cable or other cable suitable for Class I Division 1 Hazardous Locations

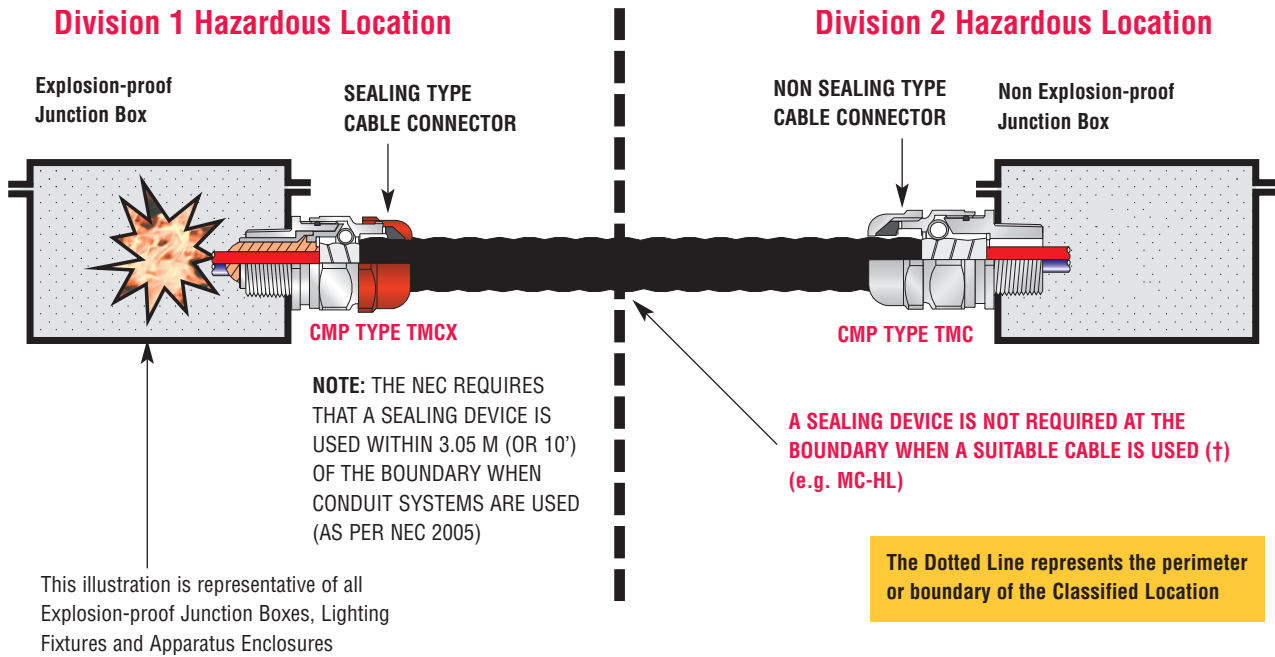

Typical Class I Zone 1 & Zone 2 Sealing Methods

MC-HL Cable or other cable suitable for Class I Zone 1 Hazardous Locations

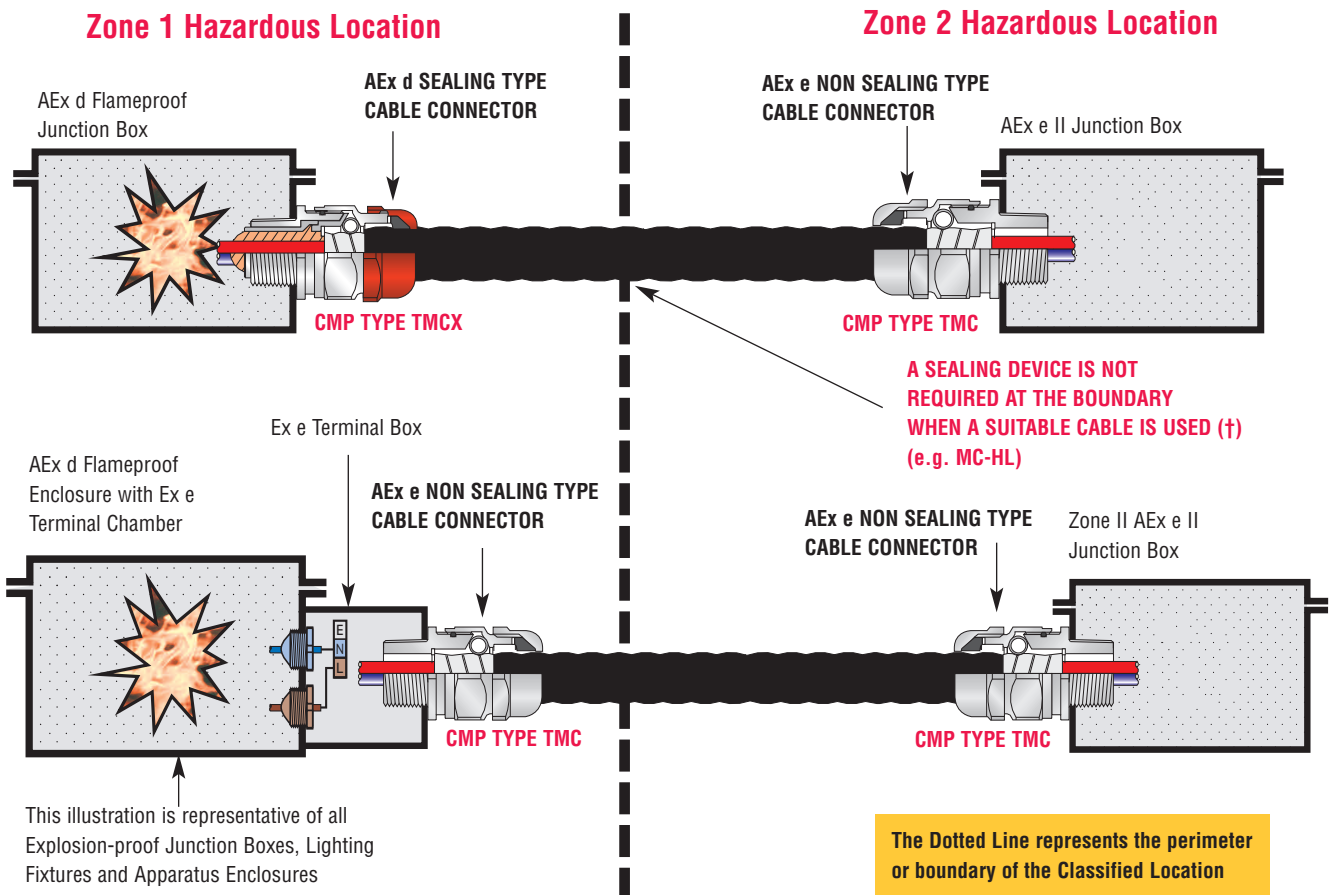

Note : (†) This condition is permitted provided the cable is not attached in the hazardous location to process equipment or devices that may cause a pressure in excess of 6 inches of water (1493 Pascals) to be exerted at a cable end. This applies when cables transit from Division 2 to Division 1, Non Hazardous and Zone 2 to Zone 1 and Zone 2 to Non Hazardous areas.

Typical Class I Zone 1 & Zone 2 Sealing Methods

MC-HL Cable or other cable suitable for Class I Zone 1 Hazardous Locations

Zone 2 Hazardous Location

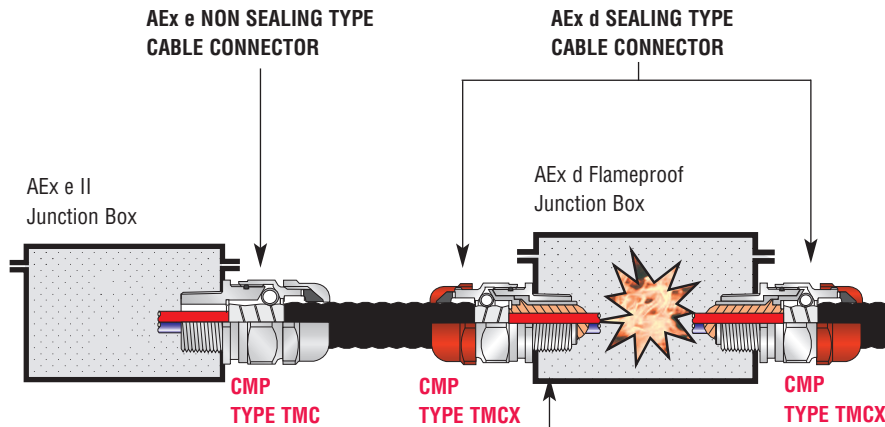

Non-Hazardous Location

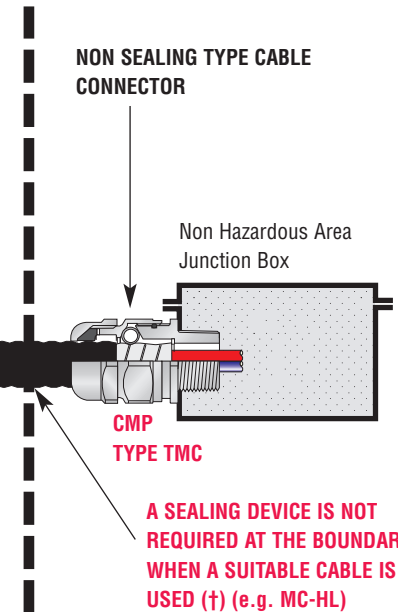

NOTE: THE NEC REQUIRES THAT A SEALING DEVICE IS USED WITHIN 3.05 M (OR 10') OF THE BOUNDARY WHEN CONDUIT SYSTEMS ARE USED (AS PER NEC 2005)

This illustration is representative of all Explosion-proof Junction Boxes, Lighting Fixtures and Apparatus Enclosures

The Dotted Line represents the perimeter or boundary of the Classified Location

Typical Class I Zone 1 & Zone 2 Sealing Methods

MC-HL Cable or other cable suitable for Class I Zone 1 Hazardous Locations

Zone 2 Hazardous Location

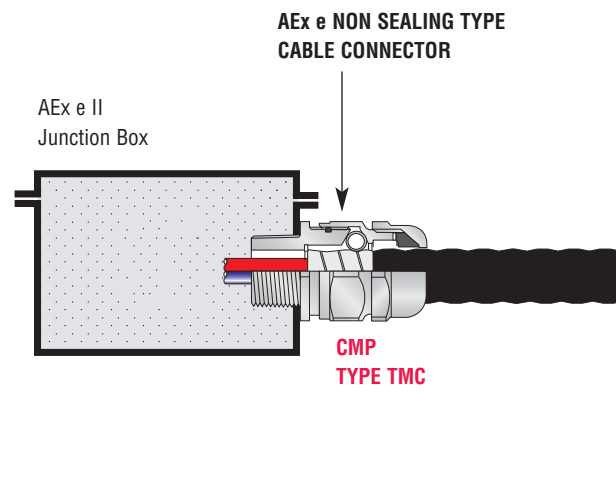

Non-Hazardous Location

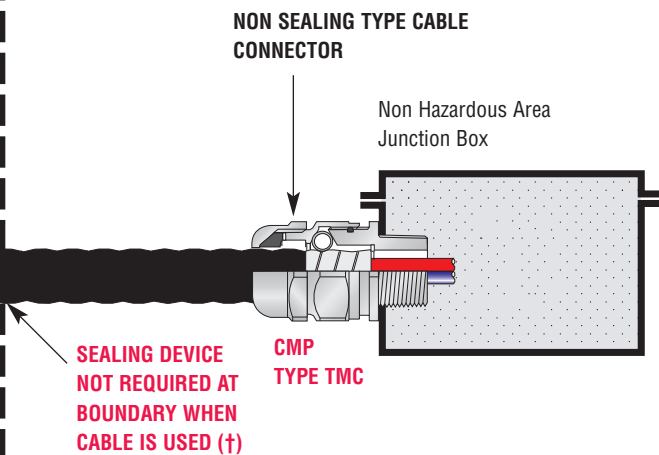

The Dotted Line represents the perimeter or boundary of the Classified Location

Note : (†) This condition is permitted provided the cable is not attached in the hazardous location to process equipment or devices that may cause a pressure in excess of 6 inches of water (1493 Pascals) to be exerted at a cable end. This applies when cables transit from Division 2 to Division 1, Non Hazardous and Zone 2 to Zone 1 and Zone 2 to Non Hazardous areas.

Typical Class I Division 1 & Division 2 Sealing Methods

MC-HL Cable or other cable suitable for Class I Division 1 Hazardous Locations

Division 2 Hazardous Location

Non-Hazardous Location

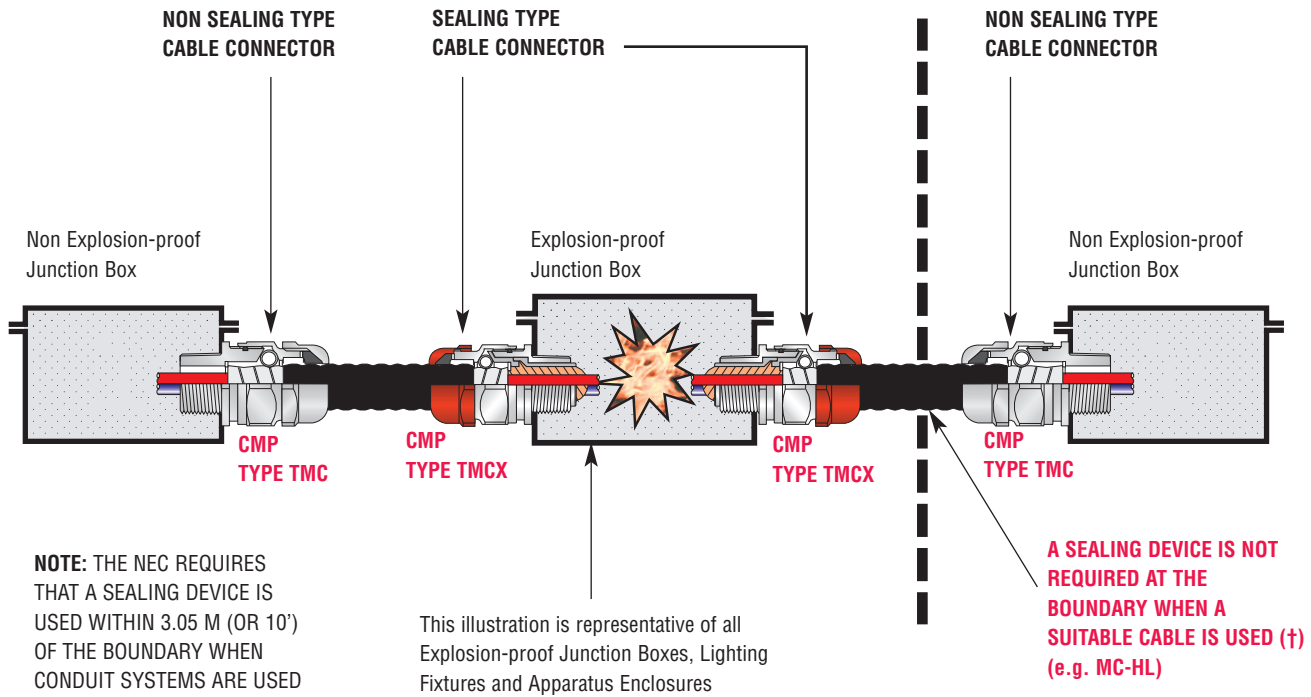

NOTE: THE NEC REQUIRES THAT A SEALING DEVICE IS USED WITHIN 3.05 M (OR 10') OF THE BOUNDARY WHEN CONDUIT SYSTEMS ARE USED (AS PER NEC 2005)

This illustration is representative of all Explosion-proof Junction Boxes, Lighting Fixtures and Apparatus Enclosures

The Dotted Line represents the perimeter or boundary of the Classified Location

Note : (†) This condition is permitted provided the cable is not attached in the hazardous location to process equipment or devices that may cause a pressure in excess of 6 inches of water (1493 Pascals) to be exerted at a cable end. This applies when cables transit from Division 2 to Division 1, Non Hazardous and Zone 2 to Zone 1 and Zone 2 to Non Hazardous areas.



INDUSTRIAL CABLE GLANDS

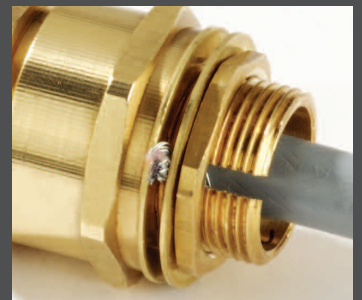
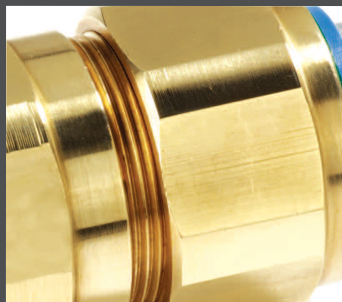
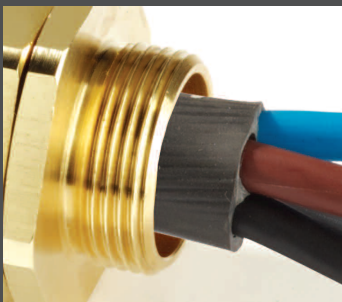

■ APPLICATION

The CMP Products range of industrial cable glands embraces products used in a wide and diverse variety of market sectors, in conjunction with virtually every kind of industrial cable installation. With a wealth of experience in terminating all types of armoured and unarmoured cables CMP has discovered that when it comes to such critical installations, quality and reliability really do count.

■ PRODUCTS

CMP cable gland options for all types of cables are available in a wide range of sizes and are supplied in a variety of thread forms. Cable glands are available in various materials including Brass, Electroless Nickel Plated Brass, Aluminium and Stainless Steel. Significantly the brass grade used in the production of all CMP brass cable glands is CuZn39Pb3 (CW614N) to EN12168, which is a highly desirable feature but quite often overlooked.

■ SPECIFICATIONS & APPROVALS

CMP Products designs and manufactures cable glands and accessories conforming to the prevailing industry standards including EN50262:1999 and the more onerous BS6121:Part 1:1989. CMP Products holds a host of internationally recognised approvals, and its product range is manufactured under a 3rd Party approved Quality Managements System conforming to ISO 9001 : 2000.

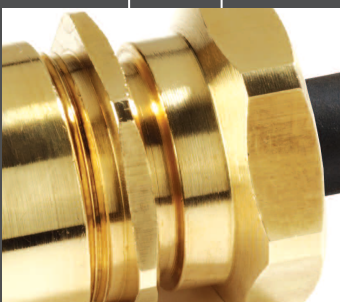

BW CABLE GLAND

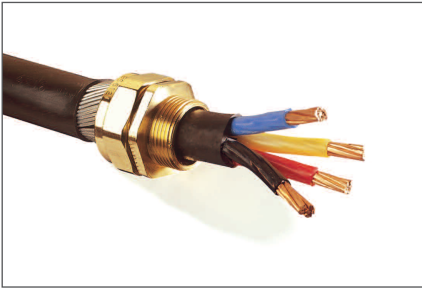

BW Industrial Cable Gland

CMP BW type brass indoor cable gland for use with all types of Single Wire Armour (SWA) cable providing mechanical cable retention and electrical continuity via armour wire termination. The CMP BW range of industrial cable glands is designed and tested to BS6121:2005, and is produced from Brass grade CuZn39Pb3 (CW614N) to EN12168

TECHNICAL DATA

Type	BW
Design Specification	BS 6121: Part 1: 2005
GOST R Certificate Number	POCC GB. ГБ 05.H00110
GOST K Certificate Number	KZ7500052.05.01.00063
RoK Permit for Use Number	08-067693
Lloyds Approval Number	01/00171
ABS Approval Number	01-LD 234401-PDA
Standard Gland Material	Brass
Alternative Gland Material	Electroless Nickel Plated Brass, Stainless Steel, Aluminium
Cable Type	Single Wire Armour (SWA), Aluminium Wire Armour (AWA)
Armour Clamping	Two Part Armour Lock
Optional Accessories	Adaptor/Reducer, Earth Tag, Locknut, Serrated Washer, Shroud
Gland Kits Available	Cable Gland Kit for use with all types of SWA cable, including 2 Brass Glands, 2 Steel Locknuts, 2 Brass Earth Tags and 2 PVC Shrouds for sizes up to and including 32mm. For sizes 40mm and above each kit includes 1 of each component.

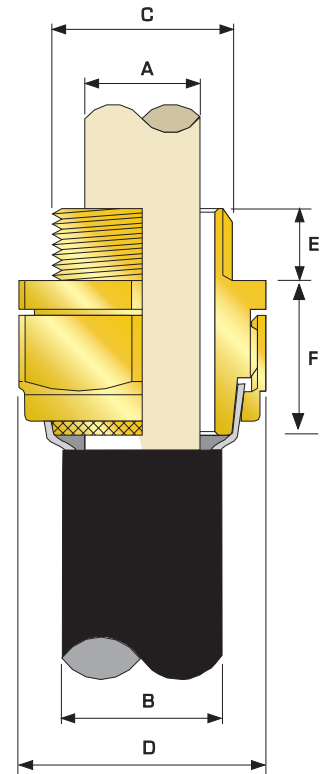

Cable Gland Selection Table

Cable Gland Size	Entry Thread 'C'	Minimum Thread Length 'E'	Cable Bedding Diameter 'A'	Overall Cable Diameter 'B'	Armour Range		Across Flats 'D'	Across Corners 'D'	Nominal Protrusion Length 'F'	Ordering Reference (Brass Metric)	PVC Shroud Reference*	Cable Gland Weight (Kgs)
			Max	Max	Min	Max	Max	Max				
20S	M20	10.0	11.7	16.1	0.9	1.25	22.0	24.0	18.0	20SBW1AA	PVC02	0.09
20	M20	10.0	14.0	21.1	0.9	1.25	28.0	30.0	22.0	20BW1AA	PVC05	0.10
25	M25	10.0	20.0	27.4	1.25	1.60	33.6	36.0	26.0	25BW1AA	PVC07	0.15
32	M32	10.0	26.3	34.4	1.6	2.00	41.0	44.5	28.0	32BW1AA	PVC10	0.20
40	M40	10.0	32.2	42.4	1.6	2.00	50.0	56.3	30.0	40BW1AA	PVC13	0.36
50S	M50	15.0	38.2	50.1	2.0	2.50	57.1	63.4	30.0	50SBW1AA	PVC16	0.48
50	M50	15.0	44.1	55.7	2.0	2.50	61.0	72.1	32.0	50BW1AA	PVC19	0.42
63S	M63	15.0	50.0	62.4	2.5	2.50	75.0	83.0	38.0	63SBW1AA	PVC22	0.80
63	M63	15.0	56.0	68.2	2.5	2.50	80.0	88.7	38.0	63BW1AA	PVC24	0.85
75S	M75	15.0	62.0	76.8	2.5	2.50	90.0	99.8	40.0	75SBW1AA	PVC27	1.30
75	M75	15.0	75.0	82.9	2.5	3.15	95.0	105.3	40.0	75BW1AA	PVC29	1.60

All dimensions in millimetres

Note: *LSF Shrouds also available on request.

BWL CABLE GLAND

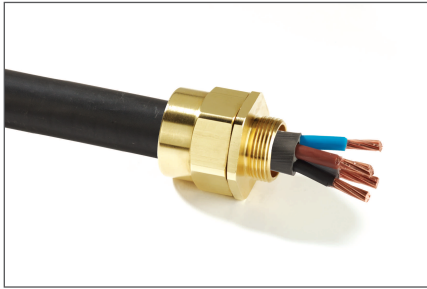

BWL Heavy Duty Industrial Cable Gland

CMP BWL type brass indoor cable gland for use with all types of Single Wire Armour (SWA) cable providing mechanical cable retention and electrical continuity via armour wire termination. The heavy duty BWL design offers the benefit of a longer body to protect the armour wires from impact. The CMP BWL range of industrial cable glands is designed and tested to BS6121:2005, and is produced from Brass grade CuZn39Pb3 (CW614N) to EN12168

TECHNICAL DATA

Type	BWL
Design Specification	BS 6121:Part 1:2005
GOST R Certificate Number	POCC GB. ГБ 05.H00110
GOST K Certificate Number	KZ7500052.05.01.00063
RoK Permit for Use Number	08-067693
Lloyds Approval Number	01/00171
ABS Approval Number	01-LD 234401-PDA
Standard Gland Material	Brass
Alternative Gland Material	Electroless Nickel Plated Brass, Stainless Steel, Aluminium
Cable Type	Single Wire Armour (SWA), Aluminium Wire Armour (AWA)
Armour Clamping	Detachable Armour Cone and Anyway Universal Clamping Ring
Optional Accessories	Adaptor/Reducer, Earth Tag, Locknut, Serrated Washer, Shroud

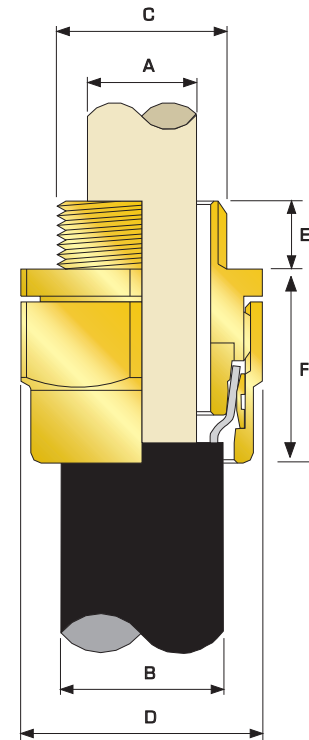

Cable Gland Selection Table

Cable Gland Size	Entry Thread 'C'	Minimum Thread Length 'E'	Cable Bedding Diameter 'A'	Overall Cable Diameter 'B'	Armour Range †		Across Flats 'D'	Across Corners 'D'	Nominal Notrusion Length 'F'	Ordering Reference (Brass Metric)	PVC Shroud Reference*	Cable Gland Weight (Kgs)
			Max	Max	Min	Max	Max	Max				
20S/16	M20	10.0	8.7	13.4	0.90	0.90	24.0	26.6	22.0	20S16BWL1RA	PVC02	0.100
20S	M20	10.0	11.7	15.9	0.90	1.25	24.0	26.6	22.0	20SBWL1RA	PVC02	0.100
20	M20	10.0	14.0	20.9	0.90	1.25	30.5	33.3	28.0	20BWL1RA	PVC04	0.130
25	M25	10.0	20.0	26.2	1.25	1.60	37.5	39.9	32.0	25BWL1RA	PVC09	0.170
32	M32	10.0	26.3	33.9	1.60	2.00	46.0	51.0	34.0	32BWL1RA	PVC11	0.282
40	M40	15.0	32.2	40.4	1.60	2.00	55.0	56.3	36.0	40BWL1RA	PVC13	0.410
50S	M50	15.0	38.2	46.7	2.00	2.50	60.0	66.5	36.0	50SBWL1RA	PVC17	0.469
50	M50	15.0	44.1	53.1	2.00	2.50	70.0	77.6	38.0	50BWL1RA	PVC20	0.434
63S	M63	15.0	50.0	59.4	2.50	2.50	75.0	83.0	44.0	63SBWL1RA	PVC22	0.883
63	M63	15.0	56.0	65.9	2.50	2.50	80.0	88.7	44.0	63BWL1RA	PVC25	0.990
75S	M75	15.0	62.0	72.1	2.50	2.50	89.0	99.8	50.0	75SBWL1RA	PVC28	1.506
75	M75	15.0	68.0	78.5	2.50	3.15	99.0	111.1	50.0	75BWL1RA	PVC30	1.954
90	M90	15.0	80.0	90.4	3.15	3.15	114.0	128.6	55.0	90BWL1RA	PVC32	2.902

All dimensions in millimetres

Note: *LSF Shrouds also available on request. † Alternative armour clamping range available for non-standard armour sizes.

C2KGP CABLE GLAND

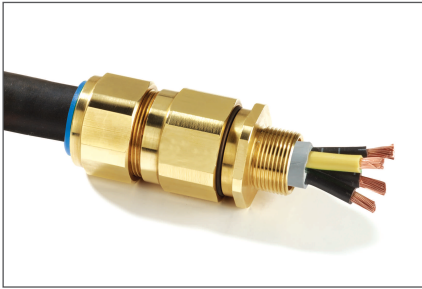

C2KGP Industrial Cable Gland

CMP C2KGP type brass indoor and outdoor cable gland for use with all types of Single Wire Armour (SWA), Wire Braid Armour, Strip Armour, Pliable Wire Armour & Steel Tape Armour (STA) cable, providing environmental seal on the cable outer sheath and additional deluge seal meeting the test requirements of DTS01:91. The cable gland also provides mechanical cable retention and electrical continuity via armour termination. A reversible armour cone and AnyWay universal clamping ring arrangement allows the cable to be easily disconnected from the equipment, for maintenance and change out etc. This feature also facilitates remote make off procedures when the termination is to be conducted in confined spaces or in areas of restricted access.

The CMP C2KGP range of industrial cable glands is designed and tested to BS 6121:Part 1:1989, meets or surpasses the requirements of EN 50262 :1999, and is produced from Brass grade CuZn39Pb3 (CW614N) to EN12168

TECHNICAL DATA	
Type	C2KGP
Design Specification	BS 6121:Part 1:1989, EN 50262:1999
EN 50262 Mechanical Classifications	Retention = Class B, Impact = Level 8,
EN 50262 Electrical Classifications	Category A without use of an Earth Tag and Category B with an Earth Tag.
GOST R Certificate Number	POCC GB. Г Б 05.H00110
GOST K Certificate Number	KZ7500052.05.01.00063
RoK Permit for Use Number	08-067693
Continuous Operating Temperature	-60°C to +150°C
Ingress Protection Rating	IP66, IP67, IP68
Ingress Protection Document	5046/C549H
Deluge Protection Compliance	DTS01 : 91
Deluge Protection Document	5046/C549H-D
Standard Gland Material	Brass
Alternative Gland Material	Electroless Nickel Plated Brass, Stainless Steel, Aluminium
Seal Material	CMP Formulated Thermoplastic Elastomer
Cable Type	Single Wire Armour (SWA), Aluminium Wire Armour (AWA), Steel Tape Armour (STA), Aluminium Strip Armour (ASA), Wire Braid Armour, Screened Flexible Wire Braid (e.g. CY / SY)
Armour Clamping	Reversible Armour Cone & AnyWay Universal Clamping Ring
Sealing Technique	Unique CMP "LRS"™ Outer Seal (Load Retention Seal)
Sealing Area(s)	Cable Outer Sheath
Optional Accessories	Adaptor/Reducer, Earth Tag, Entry Thread Seal, Locknut, Serrated Washer, Shroud

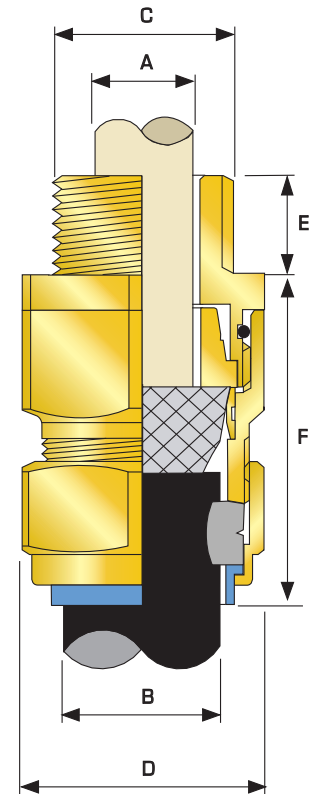

Cable Gland Selection Table

Cable Gland Size	Available Entry Threads 'C'	Minimum Thread Length 'E'	Cable Bedding Diameter 'A'	Overall Cable Diameter 'B'		Armour Range †				Across Flats 'D'	Across Corners 'D'	Nominal Protrusion Length 'F'	Ordering Reference (Brass Metric) #	PVC Shroud Reference*	Cable Gland Weight (Kgs)
						Grooved Cone		Stepped Cone							
						Min	Max	Min	Max						
20S/16	M20	10.0	8.7	6.1	11.5	0.0	1.0	0.90	1.00	30.5	33.3	47.0	20S16C2KGP1RA	PVC04	0.132
20S	M20	10.0	11.7	9.5	15.9	0.0	1.0	0.90	1.25	30.5	33.3	47.0	20SC2KGP1RA	PVC04	0.132
20	M20	10.0	14.0	12.5	20.9	0.0	1.0	0.90	1.25	30.5	33.3	50.0	20C2KGP1RA	PVC06	0.194
25S	M25	10.0	14.0	14.0	22.0	0.0	1.0	1.25	1.60	36.0	40.0	55.0	25SC2KGP1RA	PVC09	0.306
25	M25	10.0	20.0	18.2	26.2	0.0	1.0	1.25	1.60	36.0	40.0	55.0	25C2KGP1RA	PVC09	0.306
32	M32	10.0	26.3	23.7	33.9	0.0	1.0	1.60	2.00	46.0	51.0	58.0	32C2KGP1RA	PVC11	0.468
40	M40	10.0	32.2	27.9	40.4	0.0	1.0	1.60	2.00	55.0	61.0	58.0	40C2KGP1RA	PVC15	0.678
50S	M50	10.0	38.2	35.2	46.7	0.0	1.0	2.00	2.50	60.0	66.5	58.0	50SC2KGP1RA	PVC18	0.750
50	M50	10.0	44.1	40.4	53.1	0.0	1.0	2.00	2.50	70.1	78.6	60.0	50C2KGP1RA	PVC21	1.044
63S	M63	10.0	50.0	45.6	59.4	0.0	1.0	2.00	2.50	75.0	83.2	70.0	63SC2KGP1RA	PVC23	1.074
63	M63	10.0	56.0	54.6	65.9	0.0	1.0	2.00	2.50	80.0	89.0	70.0	63C2KGP1RA	PVC25	1.280
75S	M75	15.0	62.0	59.0	72.1	0.0	1.0	2.00	2.50	90.0	99.8	80.0	75SC2KGP1RA	PVC28	1.860
75	M75	15.0	68.0	66.7	78.5	0.0	1.0	2.00	2.50	100.0	111.0	82.0	75C2KGP1RA	PVC30	2.550
90	M90	15.0	80.0	76.2	90.4	0.0	1.6	3.15	3.15	115.0	127.5	96.0	90C2KGP1RA	PVC32	3.650
100	M100	15.0	91.0	89.1	101.5	0.0	1.6	3.15	4.00	123.0	136.0	106.0	100C2KGP1RA	150/50HST	4.200
115	M115	15.0	98.0	101.3	110.3	0.0	1.6	3.15	4.00	133.4	147.8	115.0	115C2KGP1RA	180/60HST	4.750
130	M130	15.0	115.0	114.0	123.3	0.0	1.6	3.15	4.00	146.1	152.4	125.0	130C2KGP1RA	180/60HST	5.330

All dimensions in millimetres

Note: *LSF Shrouds also available on request. † Alternative armour clamping range available for non-standard armour sizes. Marine approvals including Lloyds, DNV & ABS are also available from CMP Products.

CW CABLE GLAND

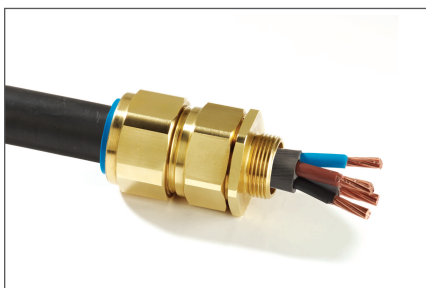

CW Industrial Cable Gland

CMP CW type brass indoor and outdoor cable gland for use with all types of Single Wire Armour (SWA) cable, providing environmental seal on the cable outer sheath. The cable gland also provides mechanical cable retention and electrical continuity via armour wire termination. A detachable armour cone and AnyWay universal clamping ring arrangement allows the cable to be easily disconnected from the equipment, for maintenance and change out etc. This feature also facilitates remote make off procedures when the termination is to be conducted in confined spaces or in areas of restricted access.

The CMP CW range of industrial cable glands is designed and tested to BS 6121:Part 1:1989, meets or surpasses the requirements of EN 50262 :1999, and is produced from Brass grade CuZn39Pb3 (CW614N) to EN12168. Other materials including Aluminium are also available in this standard design.

TECHNICAL DATA	
Type	CW
Design Specification	BS 6121:Part 1:1989, EN 50262:1999
EN 50262 Mechanical Classifications	Retention = Class B, Impact = Level 8,
EN 50262 Electrical Classifications	Category A without use of an Earth Tag and Category B with an Earth Tag.
GOST R Certificate Number	POCC GB.ГБ05.H00110
GOST K Certificate Number	KZ7500052.05.01.00063
RoK Permit for Use Number	08-067693
ABS Approval Number	01-LD 234401-PDA
Continuous Operating Temperature	-60°C to +150°C
Ingress Protection Rating	IP66
Standard Gland Material	Brass
Alternative Gland Material	Electroless Nickel Plated Brass, Stainless Steel, Aluminium
Seal Material	CMP Formulated Thermoplastic Elastomer
Cable Type	Single Wire Armour (SWA)
Armour Clamping	Detachable Armour Cone & AnyWay Universal Clamping Ring
Sealing Technique	Unique CMP "LRS"™ Outer Seal (Load Retention Seal)
Sealing Area(s)	Cable Outer Sheath
Optional Accessories	Locknut, Serrated Washer, Shroud, Adaptor/Reducer, Earth Tag, Entry Thread Seal
Cable Gland Kits Available	Cable Gland kit for use with all types of SWA cable including 2 brass glands, 2 steel locknuts, 2 brass earth tags and 2 PVC shrouds for sizes up to and including 32mm. For sizes 40mm and above each kit includes 1 of each component.

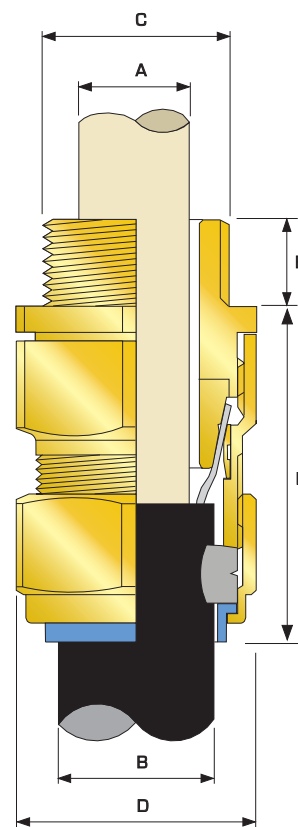

Cable Gland Selection Table

Cable Gland Size	Entry Thread 'C'	Minimum Thread Length 'E'	Cable Bedding Diameter 'A'		Overall Cable Diameter 'B'		Armour Range †		Across Flats 'D'	Across Corners 'D'	Nominal Protusion Length 'F'	Ordering Reference (Brass Metric) #	PVC Shroud Reference*	Cable Gland Weight (Kgs)
			Max	Min	Max	Min	Max	Max						
20S/16	M20	10.0	8.7	6.1	11.5	0.90	1.00	24.0	26.6	43.0	20S16CW1RA	PVC04	0.118	
20S	M20	10.0	11.7	9.5	15.9	0.90	1.25	24.0	26.6	43.0	20SCW1RA	PVC04	0.118	
20	M20	10.0	14.0	12.5	20.9	0.90	1.25	30.5	33.3	50.0	20CW1RA	PVC06	0.159	
25S	M25	10.0	19.9	14.0	22.0	1.25	1.60	36.0	40.0	55.0	25SCW1RA	PVC09	0.228	
25	M25	10.0	20.0	18.2	26.2	1.25	1.60	36.0	40.0	55.0	25CW1RA	PVC09	0.228	
32	M32	10.0	26.3	23.7	33.9	1.60	2.00	46.0	51.0	55.0	32CW1RA	PVC11	0.362	
40	M40	15.0	32.2	27.9	40.4	1.60	2.00	55.0	61.0	55.0	40CW1RA	PVC15	0.520	
50S	M50	15.0	38.2	35.2	46.7	2.00	2.50	60.0	66.5	56.0	50SCW1RA	PVC18	0.579	
50	M50	15.0	44.1	40.4	53.1	2.00	2.50	70.1	78.6	70.0	50CW1RA	PVC21	0.601	
63S	M63	15.0	50.0	45.6	59.4	2.00	2.50	75.0	83.2	70.0	63SCW1RA	PVC23	1.054	
63	M63	15.0	56.0	54.6	65.9	2.00	2.50	80.0	89.0	80.0	63CW1RA	PVC25	1.200	
75S	M75	15.0	62.0	59.0	72.1	2.00	2.50	90.0	101.6	81.0	75SCW1RA	PVC28	1.779	
75	M75	15.0	68.0	66.7	78.5	2.00	2.50	100.0	111.1	96.0	75CW1RA	PVC30	2.370	
90	M90	15.0	80.0	76.2	90.4	3.15	3.15	114.0	128.6	120.0	90CW1RA	PVC32	3.515	
100	M100	15.0	91.0	89.1	101.5	3.15	4.00	123.0	136.0	140.0	100CW1RA	150/50HST	4.100	
115	M115	15.0	98.0	101.3	110.3	3.15	4.00	133.4	147.8	160.0	115CW1RA	180/60HST	4.600	
130	M130	15.0	115.0	114.0	123.3	3.15	4.00	146.1	152.4	169.0	130CW1RA	180/60HST	5.200	

All dimensions in millimetres

Note: *LSF Shrouds also available on request. † Alternative armour clamping range available for non-standard armour sizes. Marine approvals including Lloyds, DNV & ABS are also available from CMP Products.

CX CABLE GLAND

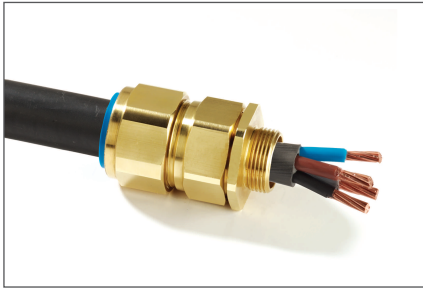

CX Industrial Cable Gland

CMP CX type brass indoor and outdoor cable gland for use with all types of Wire Braid Armour, Strip Armour, Pliable Wire Armour & Steel Tape Armour (STA) cable, providing environmental seal on the cable outer sheath. The cable gland also provides mechanical cable retention and electrical continuity via armour wire termination. A detachable armour cone and AnyWay universal clamping ring arrangement allows the cable to be easily disconnected from the equipment, for maintenance and change out etc. This feature also facilitates remote make off procedures when the termination is to be conducted in confined spaces or in areas of restricted access.

The CMP CX range of industrial cable glands is designed and tested to BS 6121:Part 1:1989, meets or surpasses the requirements of EN 50262 :1999, and is produced from Brass grade CuZn39Pb3 (CW614N) to EN12168. Other materials including Aluminium are also available in this standard design.

TECHNICAL DATA	
Type	CX
Design Specification	BS 6121:Part 1:1989, EN 50262:1999
EN 50262 Mechanical Classifications	Retention = Class B, Impact = Level 8,
EN 50262 Electrical Classifications	Category A without use of an Earth Tag and Category B with an Earth Tag.
GOST R Certificate Number	POCC GB.ГБ05.H00110
GOST K Certificate Number	KZ7500052.05.01.00063
RoK Permit for Use Number	08-067693
Lloyds Approval Number	01/00171
ABS Approval Number	01-LD 234401-PDA
Continuous Operating Temperature	-60°C to +150°C
Ingress Protection Rating	IP66
Standard Gland Material	Brass
Alternative Gland Material	Electroless Nickel Plated Brass, Stainless Steel, Aluminium
Seal Material	CMP Formulated Thermoplastic Elastomer
Cable Type	Wire Braid Armour, Screened Flexible Wire Braid (e.g. CY / SY), Pliable Wire Armour (PWA), Steel Tape Armour (STA)
Armour Clamping	Detachable Armour Cone & AnyWay Universal Clamping Ring
Sealing Technique	Unique CMP "LRS"™ Outer Seal (Load Retention Seal)
Sealing Area(s)	Cable Outer Sheath
Optional Accessories	Adaptor/Reducer, Earth Tag, Entry Thread Seal, Locknut, Serrated Washer, Shroud

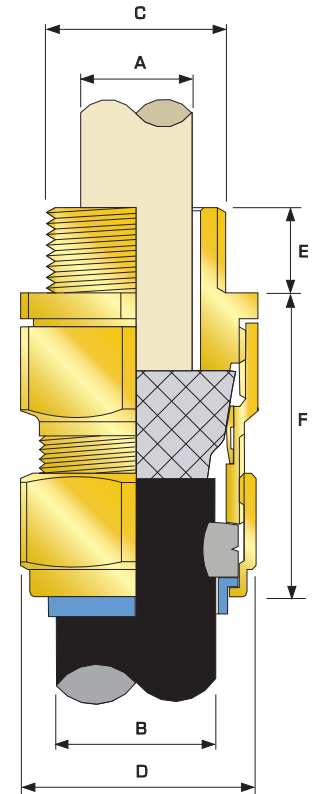

Cable Gland Selection Table

Cable Gland Size	Entry Thread 'C'	Minimum Thread Length 'E'	Cable Bedding Diameter 'A'	Overall Cable Diameter 'B'		Armour Range Grooved		Across Flats 'D'	Across Corners 'D'	Nominal Protrusion Length 'F'	Ordering Reference (Brass Metric)	PVC Shroud Reference*	Cable Gland Weight (Kgs)
				Max	Min	Min	Max						
20S/16	M20	10.0	8.7	6.1	11.5	0	1.0	24.0	26.6	43.0	20S16CX1RA	PVC04	0.118
20S	M20	10.0	11.7	9.5	15.9	0	1.0	24.0	26.6	43.0	20SCX1RA	PVC04	0.118
20	M20	10.0	14.0	12.5	20.9	0	1.0	30.5	33.3	50.0	20CX1RA	PVC06	0.159
25S	M25	10.0	19.9	14.0	22.0	0	1.0	36.0	40.0	55.0	25SCX1RA	PVC09	0.228
25	M25	10.0	20.0	18.2	26.2	0	1.0	36.0	40.0	55.0	25CX1RA	PVC09	0.228
32	M32	10.0	26.3	23.7	33.9	0	1.0	46.0	51.0	55.0	32CX1RA	PVC11	0.362
40	M40	15.0	32.2	27.9	40.4	0	1.0	55.0	61.0	55.0	40CX1RA	PVC15	0.520
50S	M50	15.0	38.2	35.2	46.7	0	1.0	60.0	66.5	56.0	50SCX1RA	PVC18	0.579
50	M50	15.0	44.1	40.4	53.1	0	1.0	70.1	78.6	70.0	50CX1RA	PVC21	0.601
63S	M63	15.0	50.0	45.6	59.4	0	1.0	75.0	83.2	70.0	63SCX1RA	PVC23	1.054
63	M63	15.0	56.0	54.6	65.9	0	1.0	80.0	89.0	80.0	63CX1RA	PVC25	1.200
75S	M75	15.0	62.0	59.0	72.1	0	1.0	90.0	101.6	81.0	75SCX1RA	PVC28	1.779
75	M75	15.0	68.0	66.7	78.5	0	1.0	100.0	111.1	96.0	75CX1RA	PVC30	2.370
90	M90	15.0	80.0	76.2	90.4	0	1.6	114.0	128.6	120.0	90CX1RA	PVC32	3.515
100	M100	15.0	91.0	89.1	101.5	0	1.6	123.0	136.0	140.0	100CX1RA	150/50HST	4.100
115	M115	15.0	98.0	101.3	110.3	0	1.6	133.4	147.8	160.0	115CX1RA	180/60HST	4.600
130	M130	15.0	115.0	114.0	123.3	0	1.6	146.1	152.4	169.0	130CX1RA	180/60HST	5.200

All dimensions in millimetres

Note: *LSF Shrouds also available on request. Marine approvals including Lloyds, DNV & ABS are also available from CMP Products.

A2 CABLE GLAND

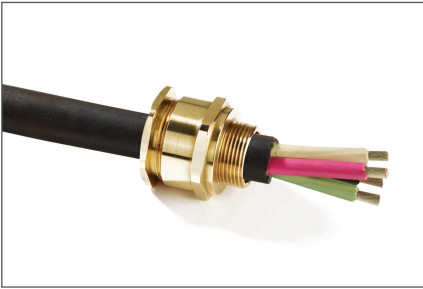

A2 Industrial Cable Gland

CMP A2 type brass indoor and outdoor cable gland for use with all types of Unarmoured cable, providing mechanical cable retention and an environmental seal on the cable outer sheath.

The CMP A2 range of industrial cable glands is designed and tested to BS 6121:Part 1:1989, meets or surpasses the requirements of EN 50262 :1999, and is produced from Brass grade CuZn39Pb3 (CW614N) to EN12168. Other materials including Aluminium are also available in this standard design.

TECHNICAL DATA	
Type	A2
Design Specification	BS 6121:Part 1:1989, EN 50262:1999
EN 50262 Mechanical Classifications	Retention = Class B, Impact = Level 8,
GOST R Certificate Number	POCC GB. ГБ05.H00110
GOST K Certificate Number	KZ7500052.05.01.00063
RoK Permit for Use Number	08-067693
Lloyds Approval Number	01/00171
ABS Approval Number	01-LD 234401-PDA
Continuous Operating Temperature	-60°C to +150°C
Ingress Protection Rating	IP66, IP67, IP68
Ingress Protection Document	5046 C549D
Deluge Protection Compliance	DTS01 : 91
Deluge Protection Document	5046 C549-D
Standard Gland Material	Brass
Alternative Gland Material	Electroless Nickel Plated Brass, Stainless Steel, Aluminium
Seal Material	CMP Formulated Thermoplastic Elastomer
Cable Type	Unarmoured
Sealing Technique	CMP Displacement Seal
Sealing Area(s)	Cable Outer Sheath
Optional Accessories	Adaptor/Reducer, Earth Tag, Entry Thread Seal, Locknut, Serrated Washer, Shroud

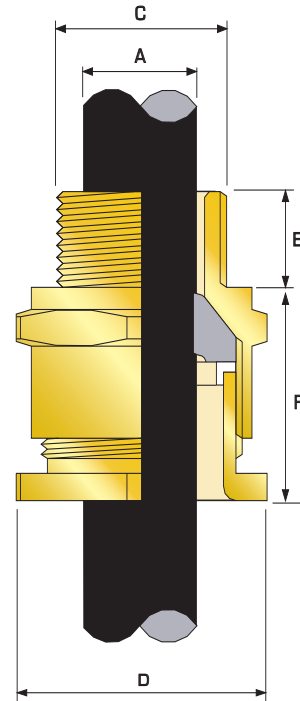

Cable Gland Selection Table

Cable Gland Size	Available Entry Threads 'C'			Minimum Thread Length 'E'	Cable Bedding Diameter 'A'		Across Flats 'D'	Across Corners 'D'	Nominal Protrusion Length 'F'	Ordering Reference (Brass Metric) #	PVC Shroud Reference*	Cable Gland Weight (Kgs)
	Standard		Option		Max	Max						
	Metric	NPT	NPT		Min	Min						
20S/16	M20	1/2"	3/4"	10.0	3.1	8.7	24.0	26.6	21.0	20S16A21RA	PVC04	0.054
20S	M20	1/2"	3/4"	10.0	6.1	11.7	24.0	26.6	21.0	20SA21RA	PVC04	0.054
20	M20	1/2"	3/4"	10.0	6.5	14.0	27.0	30.0	24.0	20A21RA	PVC05	0.059
25	M25	3/4"	1"	10.0	11.1	20.0	36.0	39.9	26.0	25A21RA	PVC09	0.112
32	M32	1"	1 1/4"	10.0	17.0	26.3	41.0	45.5	27.0	32A21RA	PVC10	0.128
40	M40	1 1/4"	1 1/2"	15.0	23.5	32.2	50.0	55.4	28.0	40A21RA	PVC13	0.168
50S	M50	1 1/2"	2"	15.0	31.0	38.2	55.0	61.0	29.0	50SA21RA	PVC14	0.224
50	M50	2"	2 1/2"	15.0	35.6	44.1	60.0	66.5	30.0	50A21RA	PVC17	0.231
63S	M63	2"	2 1/2"	15.0	41.5	50.0	70.0	77.6	30.0	63SA21RA	PVC20	0.360
63	M63	2 1/2"	3"	15.0	47.2	56.0	75.0	83.2	30.0	63A21RA	PVC22	0.344
75S	M75	2 1/2"	3"	15.0	54.0	62.0	80.0	88.7	32.0	75SA21RA	PVC24	0.466
75	M75	3"	3 1/2"	15.0	61.1	68.0	85.0	94.2	32.0	75A21RA	PVC26	0.395
90	M90	3"	3 1/2"	15.0	66.6	79.4	108.0	120.7	44.0	90A21RA	PVC31	1.346
100	M100	4"	-	15.0	76.0	91.0	123.0	137.8	48.0	100A21RA	150/50HST	1.575
115	M115	-	-	15.0	86.0	98.0	133.4	147.6	55.0	115A21RA	180/60HST	2.322
130	M130	-	-	15.0	97.0	115.0	152.4	164.9	62.0	130A21RA	180/60HST	3.400

All dimensions in millimetres

Note: *LSF Shrouds also available on request. Marine approvals including Lloyds, DNV & ABS are also available from CMP Products. # Other thread forms are available.

CXT CABLE GLAND

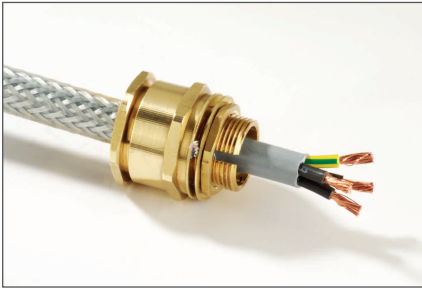

CXT Industrial Cable Gland

CMP CXT type brass indoor and outdoor cable gland for use with all types of screened flexible wire braid (e.g. CY/SY), or wire braid armour cable. The cable gland provides an environmental seal on the cable outer sheath. The cable gland also provides mechanical cable retention and electrical continuity via internal pig-tail termination of the flexible wire braid.

The CMP CXT range of industrial cable glands is designed and tested to BS 6121:Part 1:1989, meets or surpasses the requirements of EN 50262 :1999, and is produced from Brass grade CuZn39Pb3 (CW614N) to EN12168. Other materials including Aluminium are also available in this standard design.

TECHNICAL DATA

Type	CXT
Design Specification	BS 6121:Part 1:1989, EN 50262:1999
EN 50262 Mechanical Classifications	Retention = Class B, Impact = Level 8,
Continuous Operating Temperature	-60°C to +150°C
Ingress Protection Rating	IP66
Standard Gland Material	Brass
Alternative Gland Material	Electroless Nickel Plated Brass, Stainless Steel, Aluminium
Seal Material	CMP Formulated Thermoplastic Elastomer
Cable Type	Screened and Flexible Wire Braid (e.g CY / SY), Wire Braid Armour, Armored & Jacketed.
Sealing Technique	CMP Displacement Seal
Sealing Area(s)	Cable Outer Sheath
Optional Accessories	Adaptor/Reducer, Earth Tag, Entry Thread Seal, Locknut, Serrated Washer, Shroud

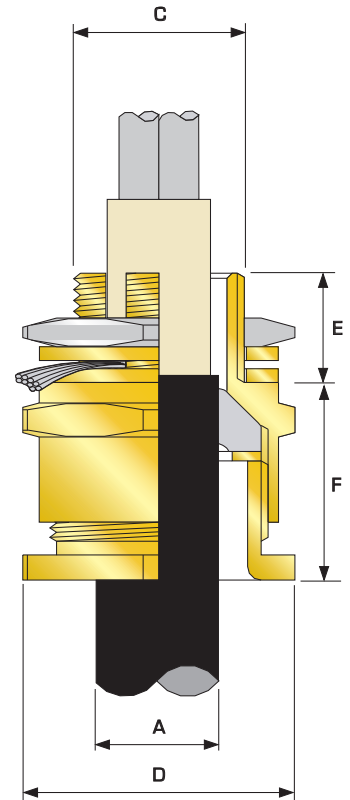

Cable Gland Selection Table

Cable Gland Size	Entry Thread 'C'	Minimum Thread Length 'E'	Cable Bedding Diameter 'A'		Across Flats 'D'	Across Corners 'D'	Nominal Protrusion Length 'F'	Ordering Reference (Brass Metric)	PVC Shroud Reference*	Cable Gland Weight (Kgs)
			Min	Max	Max	Max				
20S/16	M20	15.0	3.1	8.7	24.0	26.6	18.0	20S16CXT1RA	PVC04	0.058
20S	M20	15.0	6.1	11.7	24.0	26.6	18.0	20SCXT1RA	PVC04	0.058
20	M20	15.0	6.5	14.0	27.0	30.0	20.0	20CXT1RA	PVC05	0.062
25	M25	15.0	11.1	20.0	36.0	40.0	26.0	25CXT1RA	PVC09	0.120
32	M32	15.0	17.0	26.3	41.0	45.5	26.0	32CXT1RA	PVC10	0.134
40	M40	15.0	23.5	32.2	50.0	55.5	26.0	40CXT1RA	PVC13	0.182
50S	M50	15.0	31.0	38.2	55.0	61.5	28.0	50SCXT1RA	PVC14	0.236
50	M50	15.0	35.6	44.1	60.0	66.5	28.0	50CXT1RA	PVC17	0.244
63S	M63	15.0	41.5	50.0	70.0	77.6	28.0	63SCXT1RA	PVC20	0.377
63	M63	15.0	47.2	56.0	75.0	83.0	30.0	63CXT1RA	PVC22	0.374
75S	M75	15.0	54.0	62.0	80.0	88.7	30.0	75SCXT1RA	PVC24	0.456
75	M75	15.0	61.1	68.0	85.0	94.3	32.0	75CXT1RA	PVC26	0.388
90	M90	15.0	66.6	79.4	108.0	119.7	40.0	90CXT1RA	PVC31	1.480
100	M100	15.0	76.0	91.0	123.0	136.0	45.0	100CXT1RA	150/50HST	1.575
115	M115	15.0	89.0	98.0	133.4	148.0	48.0	115CXT1RA	180/60HST	2.322
130	M130	15.0	97.0	115.0	146.1	162.0	52.0	130CXT1RA	180/60HST	3.400

All dimensions in millimetres

Note: *LSF Shrouds also available on request. Marine approvals including Lloyds, DNV & ABS are also available from CMP Products.

SS2KGP CABLE GLAND

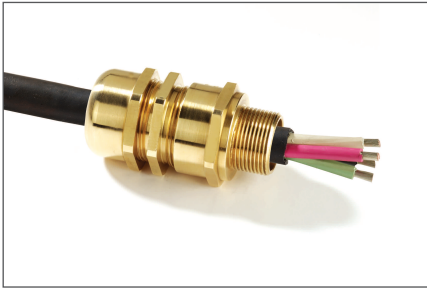

SS2KGP Industrial Cable Gland

CMP SS2KGP type brass indoor and outdoor cable gland for use with all types of Unarmoured cable, providing mechanical cable retention and an environmental seal on the cables inner and outer sheath or a double seal on the cable outer sheath. Suitable for applications where superior cable pull out resistance is required.

The CMP SS2KGP range of industrial cable glands is designed and tested to BS 6121:Part 1:1989, meets or surpasses the requirements of EN 50262 :1999, and is produced from Brass grade CuZn39Pb3 (CW614N) to EN12168.

TECHNICAL DATA	
Type	SS2K/GP
Design Specification	BS 6121:Part 1:1989, EN 50262:1999
EN 50262 Mechanical Classifications	Retention = Class B, Impact = Level 8,
GOST R Certificate Number	POCC GB. Г Б 05.H00110
GOST K Certificate Number	KZ7500052.05.01.00063
RoK Permit for Use Number	08-067693
Continuous Operating Temperature	-60°C to +150°C
Ingress Protection Rating	IP66, IP67, IP68
Ingress Protection Document	5046 C549K
Deluge Protection Compliance	DTS01 : 91
Deluge Protection Document	5046 C549K
Standard Gland Material	Brass
Alternative Gland Material	Electroless Nickel Plated Brass, Stainless Steel, Aluminium
Seal Material	CMP Formulated Thermoplastic Elastomer
Cable Type	Unarmoured
Sealing Technique	CMP Displacement Seal
Sealing Area(s)	Cable Inner Bedding and Cable Outer Sheath
Optional Accessories	Adaptor/Reducer, Earth Tag, Entry Thread Seal, Locknut, Serrated Washer, Shroud

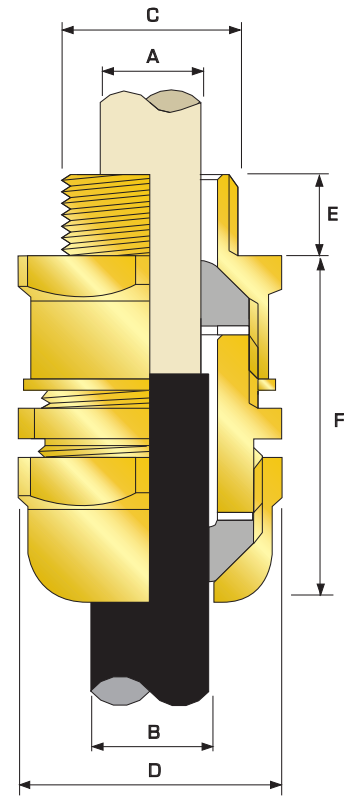

Cable Gland Selection Table

Cable Gland Size	Available Entry Threads 'C'			Minimum Thread Length 'E'	Cable Diameter 'A/B'		Across Flats 'D'	Across Corners 'D'	Nominal Protrusion Length 'F'	Ordering Reference (Brass Metric) #	PVC Shroud Reference*	Cable Gland Weight (Kgs)
	Standard		Option		Max	Max						
	Metric	NPT	NPT		Min	Max						
20S/16	M20	1/2"	3/4"	10.0	3.1	8.7	24.0	26.6	42.0	20S16SS2KGP1AA	PVC04	0.072
20S	M20	1/2"	3/4"	10.0	6.1	11.7	24.0	26.6	42.0	20SSS2KGP1AA	PVC04	0.072
20	M20	1/2"	3/4"	10.0	6.5	14.0	27.0	31.0	47.0	20SSS2KGP1AA	PVC05	0.079
25	M25	3/4"	1"	10.0	11.1	20.0	36.0	39.0	56.0	25SSS2KGP1AA	PVC09	0.149
32	M32	1"	1 1/4"	10.0	17.0	26.3	41.0	45.0	58.0	32SSS2KGP1AA	PVC10	0.170
40	M40	1 1/4"	1 1/2"	15.0	23.5	32.2	50.0	53.5	60.0	40SSS2KGP1AA	PVC13	0.224
50S	M50	1 1/2"	2"	15.0	31.0	38.2	55.0	61.0	62.0	50SSS2KGP1AA	PVC14	0.298
50	M50	2"	2 1/2"	15.0	35.6	44.1	60.0	66.0	64.0	50SSS2KGP1AA	PVC17	0.308
63S	M63	2"	2 1/2"	15.0	41.5	50.0	70.0	77.5	66.0	63SSS2KGP1AA	PVC20	0.480
63	M63	2 1/2"	3"	15.0	47.2	56.0	75.0	84.0	67.0	63SSS2KGP1AA	PVC22	0.458
75S	M75	2 1/2"	3"	15.0	54.0	62.0	79.0	87.0	68.0	75SSS2KGP1AA	PVC24	0.621
75	M75	3"	3 1/2"	15.0	61.1	68.0	84.0	94.0	70.0	75SSS2KGP1AA	PVC26	0.526
90	M90	3"	3 1/2"	15.0	66.6	79.4	108.0	120.0	75.0	90SSS2KGP1AA	PVC31	1.795
100	M100	4"	-	15.0	76.0	91.0	122.0	138.0	81.0	100SSS2KGP1AA	150/50HST	2.100
115	M115	-	-	15.0	89.0	98.0	138.0	148.0	85.0	115SSS2KGP1AA	180/60HST	3.096
130	M130	-	-	15.0	97.0	115.0	154.0	178.0	92.0	130SSS2KGP1AA	180/60HST	4.530

All dimensions in millimetres

Note: *LSF Shrouds also available on request. Marine approvals including Lloyds, DNV & ABS are also available from CMP Products. # Other thread forms are available.

SS2KGP-PB CABLE GLAND

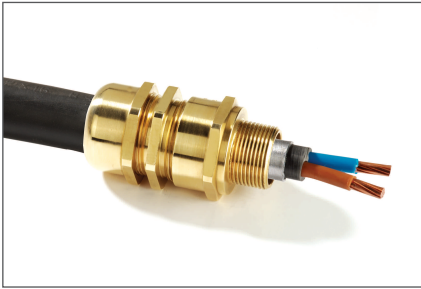

SS2KGP-PB Industrial Cable Gland

CMP SS2KGP-PB type brass indoor and outdoor cable gland for use with all types of Lead Sheathed Unarmoured, providing mechanical cable retention and environmental seal on the cable inner lead sheath and cable outer sheath. The cable gland also provides earth bonding of the inner lead covering or lead sheath.

The CMP SS2KGP-PB range of industrial cable glands is designed and tested to BS 6121:Part 1:1989, meets or surpasses the requirements of EN 50262 :1999, and is produced from Brass grade CuZn39Pb3 (CW614N) to EN12168.

TECHNICAL DATA

Type	SS2K GPPB
Design Specification	BS 6121:Part 1:1989, EN 50262:1999
EN 50262 Mechanical Classifications	Retention = Class B, Impact = Level 8,
EN 50262 Electrical Classifications	Category A without use of an Earth Tag and Category B with an Earth Tag.
GOST R Certificate Number	POCC GB. ГБ 05.H00110
GOST K Certificate Number	KZ7500052.05.01.00063
RoK Permit for Use Number	08-067693
Continuous Operating Temperature	-60° to +150°
Ingress Protection Rating	IP66, IP67, IP68
Ingress Protection Document	5046 C549K
Deluge Protection Compliance	DTS01 : 91
Deluge Protection Document	5046 C549K-D
Standard Gland Material	Brass
Alternative Gland Material	Electroless Nickel Plated Brass, Stainless Steel, Aluminium
Seal Material	CMP Formulated Thermoplastic Elastomer
Cable Type	Unarmoured Lead Sheathed
Sealing Technique	CMP Displacement Seal
Sealing Area(s)	Cable Inner Lead Sheath and Cable Outer Sheath
Optional Accessories	Adaptor/Reducer, Earth Tag, Entry Thread Seal, Locknut, Serrated Washer, Shroud

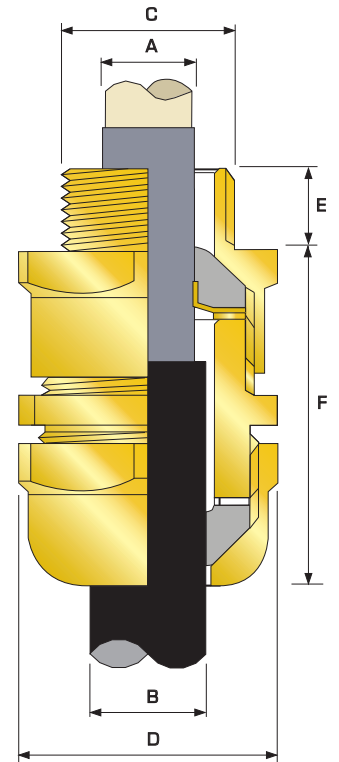

Cable Gland Selection Table

Cable Gland Size	Available Entry Threads 'C'			Minimum Thread Length 'E'	Lead Sheath/Overall Diameter 'A/B'		Across Flats 'D'	Across Corners 'D'	Nominal Protrusion Length 'F'	Ordering Reference (Brass Metric) #	PVC Shroud Reference*	Cable Gland Weight (Kgs)
	Standard		Option		Min	Max	Max	Max				
	Metric	NPT	NPT									
20S/16	M20	1/2"	3/4"	10.0	3.1	8.7	24.0	26.6	42.0	20S16SS2KGPPB1RA	PVC04	0.072
20S	M20	1/2"	3/4"	10.0	6.1	11.7	24.0	26.6	42.0	20SSS2KGPPB1RA	PVC04	0.072
20	M20	1/2"	3/4"	10.0	6.5	14.0	27.0	31.0	47.0	20SSS2KGPPB1RA	PVC05	0.079
25	M25	3/4"	1"	10.0	11.1	20.0	36.0	39.0	56.0	25SS2KGPPB1RA	PVC09	0.149
32	M32	1"	1 1/4"	10.0	17.0	26.3	41.0	45.0	58.0	32SS2KGPPB1RA	PVC10	0.170
40	M40	1 1/4"	1 1/2"	15.0	23.5	32.2	50.0	53.5	60.0	40SS2KGPPB1RA	PVC13	0.224
50S	M50	1 1/2"	2"	15.0	31.0	38.2	55.0	61.0	62.0	50SSS2KGPPB1RA	PVC14	0.298
50	M50	2"	2 1/2"	15.0	35.6	44.1	60.0	66.0	64.0	50SS2KGPPB1RA	PVC17	0.308
63S	M63	2"	2 1/2"	15.0	41.5	50.0	70.0	77.5	66.0	63SSS2KGPPB1RA	PVC20	0.480
63	M63	2 1/2"	3"	15.0	47.2	56.0	75.0	84.0	67.0	63SS2KGPPB1RA	PVC22	0.458
75S	M75	2 1/2"	3"	15.0	54.0	62.0	79.0	87.0	68.0	75SSS2KGPPB1RA	PVC24	0.621
75	M75	3"	3 1/2"	15.0	61.1	68.0	84.0	94.0	70.0	75SS2KGPPB1RA	PVC26	0.526
90	M90	3"	3 1/2"	15.0	66.6	79.4	108.0	120.0	75.0	90SS2KGPPB1RA	PVC31	1.795
100	M100	4"	-	15.0	76.0	91.0	122.0	138.0	81.0	100SS2KGPPB1RA	150/50HST	2.100
115	M115	-	-	15.0	89.0	98.0	138.0	148.0	85.0	115SS2KGPPB1RA	180/60HST	3.096
130	M130	-	-	15.0	97.0	115.0	154.0	178.0	92.0	130SS2KGPPB1RA	180/60HST	4.530

All dimensions in millimetres

Note: *LSF Shrouds also available on request. Marine approvals including Lloyds, DNV & ABS are also available from CMP Products. # Other thread forms are available.

A2RC CABLE GLAND

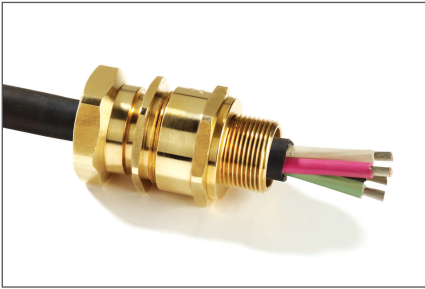

A2RC Industrial Cable Gland With Conduit Connection Facility

CMP A2RC type brass indoor and outdoor conduit connection cable gland for use with all types of Unarmoured cables housed in rigid or flexible conduit systems. The cable gland is equipped with a rotating male or female connection which is available in a variety of thread forms for ease of conduit installation, including NPT and Metric. Customers are requested to kindly specify the male and female thread form and sizes required when ordering.

The CMP A2RC range of industrial cable glands is designed and tested to BS 6121:Part 1:1989, meets or surpasses the requirements of EN 50262 :1999, and is produced from Brass grade CuZn39Pb3 (CW614N) to EN12168.

TECHNICAL DATA	
Type	A2RC
Design Specification	BS 6121:Part 1:1989, EN 50262:1999
EN 50262 Mechanical Classifications	Retention = Class B, Impact = Level 8,
EN 50262 Electrical Classifications	Category A without use of an Earth Tag and Category B with an Earth Tag.
GOST R Certificate Number	POCC GB. ГБ05.H00110
GOST K Certificate Number	KZ7500052.05.01.00063
RoK Permit for Use Number	08-067693
Continuous Operating Temperature	-60°C to +150°C
Ingress Protection Rating	IP66
Standard Gland Material	Brass
Alternative Gland Material	Electroless Nickel Plated Brass, Stainless Steel, Aluminium
Seal Material	CMP Formulated Thermoplastic Elastomer
Cable Type	Unarmoured
Sealing Technique	CMP Displacement Seal
Sealing Area(s)	Cable Outer Sheath
Optional Accessories	Adaptor/Reducer, Earth Tag, Entry Thread Seal, Locknut, Serrated Washer, Shroud

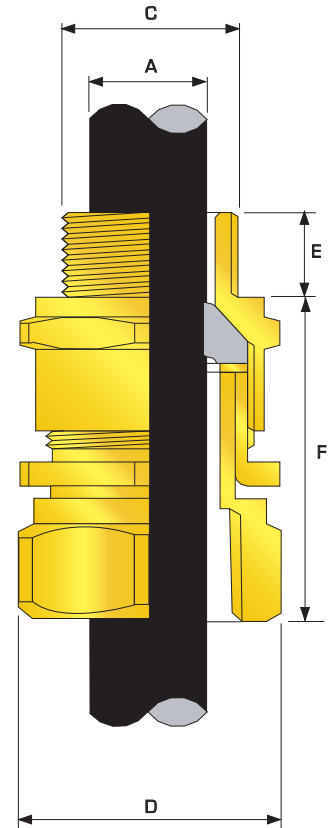

Cable Gland Selection Table

Cable Gland Size	Available Entry Threads 'C'			Standard Female NPT Thread	Minimum Thread Length 'E'	Cable Bedding Diameter 'A'		Across Flats 'D'	Across Corners 'D'	Nominal Protrusion Length 'F'	Ordering Reference (Metric Mx NPT F) #	Cable Gland Weight (Kgs)
	Standard	Option				Min	Max					
		Metric	NPT					NPT	Max	Max		
20S/16	M20	1/2"	3/4"	1/2"	10.0	3.1	8.7	24.0	26.6	42.0	20S16A2RC1RA031	0.075
20S	M20	1/2"	3/4"	1/2"	10.0	6.1	11.7	24.0	26.6	42.0	20SA2RC1RA031	0.075
20	M20	1/2"	3/4"	1/2"	10.0	6.5	14.0	27.0	30.0	47.0	20A2RC1RA031	0.082
25	M25	3/4"	1"	3/4"	10.0	18.2	20.0	36.0	39.9	56.0	25A2RC1RA032	0.165
32	M32	1"	1 1/4"	1"	10.0	23.7	26.3	41.0	45.5	58.0	32A2RC1RA033	0.180
40	M40	1 1/4"	1 1/2"	1 1/4"	15.0	27.9	32.2	50.0	55.4	60.0	40A2RC1RA034	0.250
50S	M50	1 1/2"	2"	1 1/2"	15.0	35.2	38.2	55.0	61.0	62.0	50SA2RC1RA035	0.310
50	M50	2"	2 1/2"	2"	15.0	40.4	44.1	60.0	66.5	64.0	50A2RC1RA036	0.330
63S	M63	2"	2 1/2"	2"	15.0	40.1	50.0	70.0	77.6	66.0	63SA2RC1RA036	0.480
63	M63	2 1/2"	3"	2 1/2"	15.0	47.2	56.0	75.0	83.2	67.0	63A2RC1RA037	0.460
75S	M75	2 1/2"	3"	2 1/2"	15.0	59.0	62.0	80.0	88.7	68.0	75SA2RC1RA037	0.650
75	M75	3"	3 1/2"	3"	15.0	66.7	68.0	85.0	94.2	70.0	75A2RC1RA038	0.580
90	M90	3"	3 1/2"	3"	15.0	76.2	79.4	108.0	120.7	75.0	90A2RC1RA038	0.900

All dimensions in millimetres

Note: *LSF Shrouds also available on request. Marine approvals including Lloyds, DNV & ABS are also available from CMP Products. # Other thread forms are available.

E1U CABLE GLAND

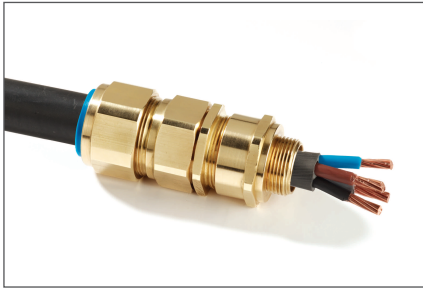

E1U Universal Industrial Cable Gland

CMP E1U type brass indoor and outdoor cable gland for use with all types of armoured cables providing an environmental seal on the cable inner bedding and on the cable outer sheath. The cable gland provides mechanical cable retention and electrical continuity via the armour termination. A reversible armour cone and AnyWay universal clamping ring arrangement allows the cable to be easily disconnected from the equipment, for maintenance and change out etc. This feature also facilitates remote make off procedures when the termination is to be conducted in confined spaces or in areas of restricted access. Separate tightening actions for the inner displacement seal and the armour termination affords maximum control over the pressure applied to the cable inner bedding.

The CMP E1U range of industrial cable glands is designed and tested to BS 6121:Part 1:1989, meets or surpasses the requirements of EN 50262 :1999, and is produced from Brass grade CuZn39Pb3 (CW614N) to EN12168.

TECHNICAL DATA

Type	E1U
Design Specification	BS 6121: Part 1: 1989, EN 50262:1999
EN 50262 Mechanical Classifications	Retention = Class B, Impact = Level 8,
EN 50262 Electrical Classifications	Category A without use of an Earth Tag and Category B with an Earth Tag.
GOST R Certificate Number	POCC GB. ГБ05.H00110
GOST K Certificate Number	KZ7500052.05.01.00063
RoK Permit for Use Number	08-067693
Lloyds Approval Number	01/00171
ABS Approval Number	01-LD 234401-PDA
Continuous Operating Temperature	-60°C to +150°C
Ingress Protection Rating	IP66 (IP67/IP68 also available)
Standard Gland Material	Brass
Alternative Gland Material	Electroless Nickel Plated Brass, Stainless Steel, Aluminium
Seal Material	CMP Formulated Thermoplastic Elastomer
Cable Type	Single Wire Armour (SWA), Aluminium Wire Armour (AWA), Pliable Wire Armour (PWA), Steel Tape Armour (STA), Wire Braid Armour, Aluminium Strip Armour (ASA), Screened Flexible Wire Braid (e.g. CY / SY), Armored & Jacketed
Armour Clamping	Reversible Armour Cone & AnyWay Universal Clamping Ring
Sealing Technique	CMP Inner Displacement Seal & Unique CMP "LRS"™ Outer Seal (Load Retention Seal)
Sealing Area(s)	Cable Inner Bedding & Cable Outer Sheath
Optional Accessories	Adaptor/Reducer, Earth Tag, Entry Thread Seal, Locknut, Serrated Washer, Shroud

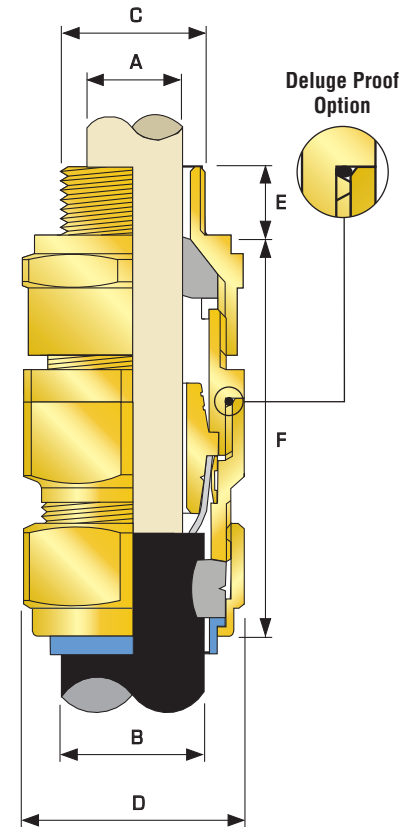

Note: Deluge proof version available

Cable Gland Selection Table

Cable Gland Size	Available Entry Threads 'C'			Minimum Thread Length 'E'	Cable Bedding Diameter 'A'		Overall Cable Diameter 'B'		Armour Range †				Across Flats 'D'	Across Corners 'D'	Nominal Protusion Length 'F'	Ordering Reference (Brass Metric) #	PVC Shroud Reference*	Cable Gland Weight (Kgs)
	Standard		Option		Min	Max	Min	Max	Grooved Cone		Stepped Cone							
	Metric	NPT	NPT						Min	Max	Min	Max						
20S/16	M20	1/2"	3/4"	10.0	3.1	8.7	6.1	11.5	0	1.0	0.9	1.0	24.0	26.6	63.0	20S16E1U1RA	PVC04	0.163
20S	M20	1/2"	3/4"	10.0	6.1	11.7	9.5	15.9	0	1.0	0.9	1.25	24.0	26.6	63.0	20SE1U1RA	PVC04	0.163
20	M20	1/2"	3/4"	10.0	6.5	14.0	12.5	20.9	0	1.0	0.9	1.25	30.5	33.3	67.0	20E1U1RA	PVC06	0.217
25S	M25	3/4"	1"	10.0	11.1	20.0	14.0	22.0	0	1.0	1.25	1.6	37.5	40.5	78.0	25SE1U1RA	PVC09	0.345
25	M25	3/4"	1"	10.0	11.1	20.0	18.2	26.2	0	1.0	1.25	1.6	37.5	40.5	78.0	25E1U1RA	PVC09	0.345
32	M32	1"	1-1/4"	15.0	17.0	26.3	23.7	33.9	0	1.0	1.6	2.0	46.0	51.0	78.0	32E1U1RA	PVC11	0.484
40	M40	1-1/4"	1-1/2"	15.0	22.0	32.2	27.9	40.4	0	1.0	1.6	2.0	55.0	61.0	83.0	40E1U1RA	PVC15	0.700
50S	M50	1-1/2"	2"	15.0	29.5	38.2	35.2	46.7	0	1.0	2.0	2.5	60.0	66.5	78.0	50SE1U1RA	PVC18	0.800
50	M50	2"	2-1/2"	15.0	35.6	44.1	40.4	53.1	0	1.0	2.0	2.5	70.0	78.6	81.0	50E1U1RA	PVC21	0.830
63S	M63	2"	2-1/2"	15.0	40.1	50.0	45.6	59.4	0	1.0	2.0	2.5	75.0	83.2	93.0	63SE1U1RA	PVC23	1.415
63	M63	2-1/2"	3"	15.0	47.2	56.0	54.6	65.9	0	1.0	2.0	2.5	80.0	89.0	95.0	63E1U1RA	PVC25	1.514
75S	M75	2-1/2"	3"	15.0	52.8	62.0	59.0	72.1	0	1.0	2.0	2.5	89.0	101.6	103.0	75SE1U1RA	PVC28	2.199
75	M75	3"	3-1/2"	15.0	59.1	68.0	66.7	78.5	0	1.0	2.0	2.5	99.0	111.1	110.0	75E1U1RA	PVC30	2.770
90	M90	3"	3-1/2"	15.0	66.6	79.4	76.2	90.4	0	1.6	3.15	3.15	114.0	128.6	136.0	90E1U1RA	PVC32	4.478
100	M100	4"	-	15.0	76.0	91.0	89.1	101.5	0	1.6	3.15	4.0	123.0	138.0	145.0	100E1U1RA	150/50HST	4.700
115	M115	-	-	15.0	86.0	98.0	101.3	110.3	0	1.6	3.15	4.0	133.4	147.6	160.0	115E1U1RA	180/60HST	5.300
130	M130	-	-	15.0	97.0	115.0	114.0	123.3	0	1.6	3.15	4.0	146.1	161.9	185.0	130E1U1RA	180/60HST	5.900

All dimensions in millimetres

Note: *LSF Shrouds also available on request. † Alternative armour clamping range available for non-standard armour sizes. Marine approvals including Lloyds, DNV & ABS are also available from CMP Products. # Other thread forms are available.

E2U CABLE GLAND

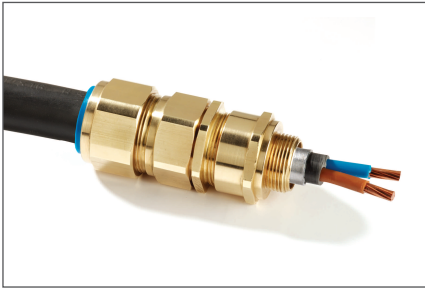

E2U Universal Industrial Cable Gland

CMP E2U type brass indoor and outdoor cable gland for use with all types of Lead Sheathed and Armoured cables providing an environmental seal on inner lead sheath and the cable outer sheath. The cable gland provides mechanical cable retention and electrical continuity via the armour termination and also earth bonding of the inner lead covering or lead sheath. A reversible armour cone and AnyWay universal clamping ring arrangement allows the cable to be easily disconnected from the equipment, for maintenance and change out etc. This feature also facilitates remote make off procedures when the termination is to be conducted in confined spaces or in areas of restricted access. Separate tightening actions for the inner displacement seal and the armour termination affords maximum control over the pressure applied to the cable inner lead covering.

The CMP E2U range of industrial cable glands is designed and tested to BS 6121:Part 1:1989, meets or surpasses the requirements of EN 50262 :1999, and is produced from Brass grade CuZn39Pb3 (CW614N) to EN12168.

TECHNICAL DATA	
Type	E2U
Design Specification	BS 6121: Part 1: 1989, EN 50262:1999
EN 50262 Mechanical Classifications	Retention = Class B, Impact = Level 8,
EN 50262 Electrical Classifications	Category A without use of an Earth Tag and Category B with an Earth Tag.
GOST R Certificate Number	POCC GB. Γ E05.H00110
GOST K Certificate Number	KZ7500052.05.01.00063
RoK Permit for Use Number	08-067693
Lloyds Approval Number	01/00171
ABS Approval Number	01-LD 234401-PDA
Continuous Operating Temperature	-60°C to +150°C
Ingress Protection Rating	IP66 (IP67/IP68 also available)
Standard Gland Material	Brass
Alternative Gland Material	Electroless Nickel Plated Brass, Stainless Steel, Aluminium
Seal Material	CMP Formulated Thermoplastic Elastomer
Cable Type	Lead Sheathed & Single Wire Armour (LC/SWA), Lead Sheathed & Wire Braid Armour, Lead Sheathed & Steel Tape Armour (LC/STA)
Armour Clamping	Reversible Armour Cone & AnyWay Universal Clamping Ring
Sealing Technique	CMP Inner Displacement Seal & Unique CMP "LRS"™ Outer Seal (Load Retention Seal)
Sealing Area(s)	Cable Inner Lead Sheath & Outer Sheath
Optional Accessories	Adaptor/Reducer, Earth Tag, Entry Thread Seal, Locknut, Serrated Washer, Shroud

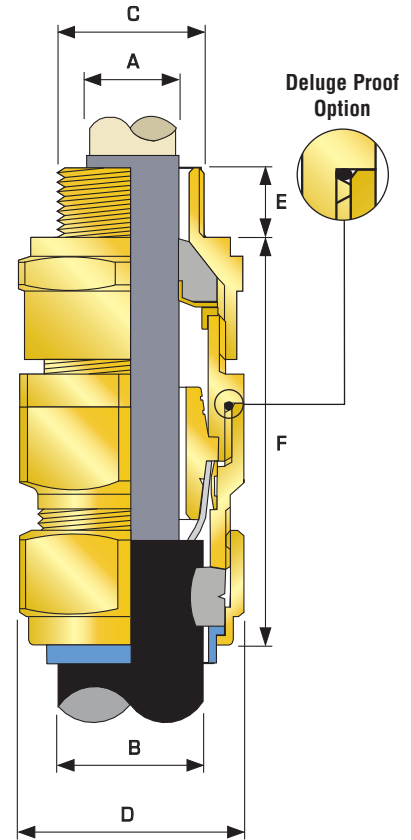

Note: Deluge proof version available

Cable Gland Selection Table

Cable Gland Size	Available Entry Threads 'C'			Minimum Thread Length 'E'	Cable Lead Sheath Diameter 'A'		Overall Cable Diameter 'B'		Armour Range †				Across Flats 'D'	Across Corners 'D'	Nominal Protrusion Length 'F'	Ordering Reference (Brass Metric) #	PVC Shroud Reference*	Cable Gland Weight (Kgs)
	Standard		Option		Min	Max	Min	Max	Grooved Cone		Stepped Cone							
	Metric	NPT	NPT						Min	Max	Min	Max						
20S/16	M20	1/2"	3/4"	10.0	3.1	8.7	6.1	11.5	0.0	1.0	0.9	1.0	24.0	26.6	63.0	20S16E2U1RA	PVC04	0.163
20S	M20	1/2"	3/4"	10.0	6.1	11.7	9.5	15.9	0.0	1.0	0.9	1.25	24.0	26.6	63.0	20SE2U1RA	PVC04	0.163
20	M20	1/2"	3/4"	10.0	6.5	14.0	12.5	20.9	0.0	1.0	0.9	1.25	30.5	33.3	67.0	20E2U1RA	PVC06	0.217
25S	M25	3/4"	1"	10.0	11.1	20.0	14.0	22.0	0.0	1.0	1.25	1.6	37.5	40.5	78.0	25SE2U1RA	PVC09	0.345
25	M25	3/4"	1"	10.0	11.1	20.0	18.2	26.2	0.0	1.0	1.25	1.6	37.5	40.5	78.0	25E2U1RA	PVC09	0.345
32	M32	1"	1-1/4"	15.0	17.0	26.3	23.7	33.9	0.0	1.0	1.6	2.0	46.0	51.0	78.0	32E2U1RA	PVC11	0.484
40	M40	1-1/4"	1-1/2"	15.0	22.0	32.2	27.9	40.4	0.0	1.0	1.6	2.0	55.0	61.0	83.0	40E2U1RA	PVC15	0.700
50S	M50	1-1/2"	2"	15.0	29.5	38.2	35.2	46.7	0.0	1.0	2.0	2.5	60.0	66.5	78.0	50SE2U1RA	PVC18	0.800
50	M50	2"	2-1/2"	15.0	35.6	44.1	40.4	53.1	0.0	1.0	2.0	2.5	70.0	78.6	81.0	50E2U1RA	PVC21	0.830
63S	M63	2"	2-1/2"	15.0	40.1	50.0	45.6	59.4	0.0	1.0	2.0	2.5	75.0	83.2	93.0	63SE2U1RA	PVC23	1.415
63	M63	2-1/2"	3"	15.0	47.2	56.0	54.6	65.9	0.0	1.0	2.0	2.5	80.0	89.0	95.0	63E2U1RA	PVC25	1.514
75S	M75	2-1/2"	3"	15.0	52.8	62.0	59.0	72.1	0.0	1.0	2.0	2.5	89.0	101.6	103.0	75SE2U1RA	PVC28	2.199
75	M75	3"	3-1/2"	15.0	59.1	68.0	66.7	78.5	0.0	1.0	2.0	2.5	99.0	111.1	110.0	75E2U1RA	PVC30	2.770
90	M90	3"	3-1/2"	15.0	66.6	79.4	76.2	90.4	0.0	1.6	3.15	3.15	114.0	128.6	136.0	90E2U1RA	PVC32	4.478
100	M100	4"	-	15.0	76.0	91.0	89.1	101.5	0.0	1.6	3.15	4.0	123.0	138.0	145.0	100E2U1RA	150/60HST	4.700
115	M115	-	-	15.0	86.0	98.0	101.3	110.3	0.0	1.6	3.15	4.0	133.4	147.6	160.0	115E2U1RA	180/60HST	5.300
130	M130	-	-	15.0	97.0	115.0	114.0	123.3	0.0	1.6	3.15	4.0	146.1	161.9	185.0	130E2U1RA	180/60HST	5.900

All dimensions in millimetres

Note: *LSF Shrouds also available on request. † Alternative armour clamping range available for non-standard armour sizes. Marine approvals including Lloyds, DNV & ABS are also available from CMP Products. # Other thread forms are available.



E1W CABLE GLAND

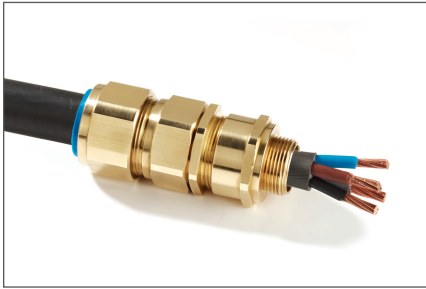

E1W Industrial Cable Gland

CMP E1W type brass indoor and outdoor cable gland for use with Single Wire Armour (SWA) cable providing an environmental seal on the cable inner sheath and the cable outer sheath. The cable gland provides mechanical cable retention and electrical continuity via armour wire termination. A detachable armour cone and AnyWay universal clamping ring arrangement allows the cable to be easily disconnected from the equipment, for maintenance and change out etc. This feature also facilitates remote make off procedures when the termination is to be conducted in confined spaces or in areas of restricted access. Separate tightening actions for the inner displacement seal and the armour termination affords maximum control over the pressure applied to the cable inner bedding.

The CMP E1W range of industrial cable glands is designed and tested to BS 6121:Part 1:1989, meets or surpasses the requirements of EN 50262 :1999, and is produced from Brass grade CuZn39Pb3 (CW614N) to EN12168. Other materials including Aluminium are also available in this standard design.

TECHNICAL DATA

Type	E1W
Design Specification	BS 6121:Part 1:1989, EN 50262:1999
EN 50262 Mechanical Classifications	Retention = Class B, Impact = Level 8,
EN 50262 Electrical Classifications	Category A without use of an Earth Tag and Category B with an Earth Tag.
GOST R Certificate Number	POCC GB. ГБ05.H00110
GOST K Certificate Number	KZ7500052.05.01.00063
RoK Permit for Use Number	08-067693
Lloyds Approval Number	01/00171
ABS Approval Number	01-LD 234401-PDA
Continuous Operating Temperature	-60°C to +150°C
Ingress Protection Rating	IP66 (IP67/IP68 also available)
Standard Gland Material	Brass
Alternative Gland Material	Electroless Nickel Plated Brass, Stainless Steel, Aluminium
Seal Material	CMP Formulated Thermoplastic Elastomer
Cable Type	Single Wire Armour (SWA)
Armour Clamping	Detachable Armour Cone & AnyWay Universal Clamping Ring
Sealing Technique	CMP Inner Displacement Seal & Unique CMP "LRS"™ Outer Seal (Load Retention Seal)
Sealing Area(s)	Cable Inner Bedding & Cable Outer Sheath
Optional Accessories	Adaptor/Reducer, Earth Tag, Entry Thread Seal, Locknut, Serrated Washer, Shroud

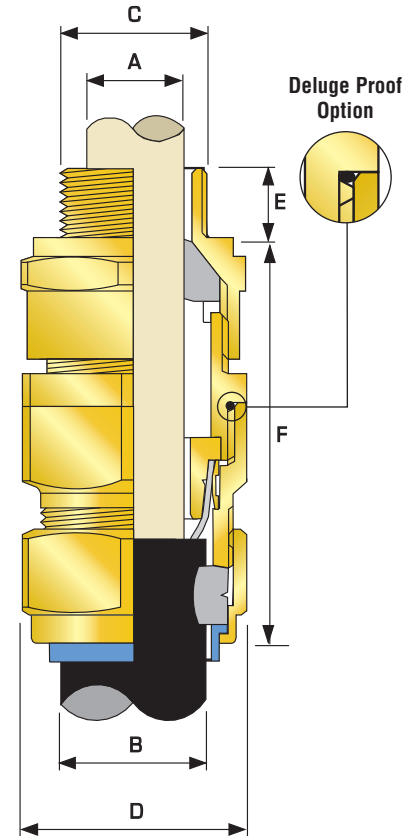

Note: Deluge proof version available

Cable Gland Selection Table

Cable Gland Size	Available Entry Threads 'C'			Minimum Thread Length 'E'	Cable Bedding Diameter 'A'		Overall Cable Diameter 'B'		Armour Range †		Across Flats 'D'	Across Corners 'D'	Nominal Protusion Length 'F'	Ordering Reference (Brass Metric) #	PVC Shroud Reference*	Cable Gland Weight (Kgs)
	Standard		Option		Min	Max	Min	Max	Min	Max						
	Metric	NPT	NPT													
20S/16	M20	1/2"	3/4"	10.0	3.1	8.7	6.1	11.5	0.9	1.0	24.0	26.6	63.0	20S16E1W1RA	PVC04	0.163
20S	M20	1/2"	3/4"	10.0	6.1	11.7	9.5	15.9	0.9	1.25	24.0	26.6	63.0	20SE1W1RA	PVC04	0.163
20	M20	1/2"	3/4"	10.0	6.5	14.0	12.5	20.9	0.9	1.25	30.5	33.3	67.0	20E1W1RA	PVC06	0.217
25S	M25	3/4"	1"	10.0	11.1	20.0	14.0	22.0	1.25	1.6	37.5	40.5	78.0	25SE1W1RA	PVC09	0.345
25	M25	3/4"	1"	10.0	11.1	20.0	18.2	26.2	1.25	1.6	37.5	40.5	78.0	25E1W1RA	PVC09	0.345
32	M32	1"	1-1/4"	15.0	17.0	26.3	23.7	33.9	1.6	2.0	46.0	51.0	78.0	32E1W1RA	PVC11	0.484
40	M40	1-1/4"	1-1/2"	15.0	22.0	32.2	27.9	40.4	1.6	2.0	55.0	61.0	83.0	40E1W1RA	PVC15	0.700
50S	M50	1-1/2"	2"	15.0	29.5	38.2	35.2	46.7	2.0	2.5	60.0	66.5	78.0	50SE1W1RA	PVC18	0.800
50	M50	2"	2-1/2"	15.0	35.6	44.1	40.4	53.1	2.0	2.5	70.0	78.6	81.0	50E1W1RA	PVC21	0.830
63S	M63	2"	2-1/2"	15.0	40.1	50.0	45.6	59.4	2.0	2.5	75.0	83.2	93.0	63SE1W1RA	PVC23	1.415
63	M63	2-1/2"	3"	15.0	47.2	56.0	54.6	65.9	2.0	2.5	80.0	89.0	95.0	63E1W1RA	PVC25	1.514
75S	M75	2-1/2"	3"	15.0	52.8	62.0	59.0	72.1	2.0	2.5	89.0	101.6	103.0	75SE1W1RA	PVC28	2.199
75	M75	3"	3-1/2"	15.0	59.1	68.0	66.7	78.5	2.0	2.5	99.0	111.1	110.0	75E1W1RA	PVC30	2.770
90	M90	3"	3-1/2"	15.0	66.6	79.4	76.2	90.4	3.15	3.15	114.0	128.6	136.0	90E1W1RA	PVC32	4.478
100	M100	4"	-	15.0	76.0	91.0	89.1	101.5	3.15	4.0	123.0	138.0	145.0	100E1W1RA	150/50HST	4.700
115	M115	-	-	15.0	86.0	98.0	101.3	110.3	3.15	4.0	133.4	147.6	160.0	115E1W1RA	180/60HST	5.300
130	M130	-	-	15.0	97.0	115.0	114.0	123.3	3.15	4.0	146.1	161.9	185.0	130E1W1RA	180/60HST	5.900

All dimensions in millimetres

Note: *LSF Shrouds also available on request. † Alternative armour clamping range available for non-standard armour sizes. Marine approvals including Lloyds, DNV & ABS are also available from CMP Products. # Other thread forms are available.

E2W CABLE GLAND

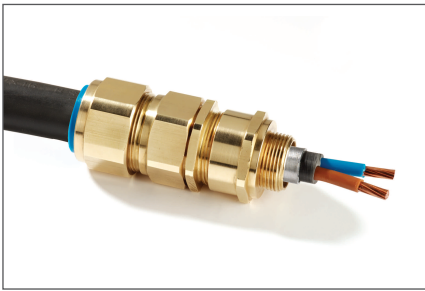

E2W Industrial Cable Gland

CMP E2W type brass indoor and outdoor cable gland for use with all types of Lead Sheathed and Single Wire Armour (SWA) cable providing an environmental seal on the cable inner lead sheath and cable outer sheath. The cable gland provides mechanical cable retention and electrical continuity via the armour termination and also earth bonding of the inner lead covering or lead sheath. A detachable armour cone and AnyWay universal clamping ring arrangement allows the cable to be easily disconnected from the equipment, for maintenance and change out etc. This feature also facilitates remote make off procedures when the termination is to be conducted in confined spaces or in areas of restricted access. Separate tightening actions for the inner displacement seal and the armour termination affords maximum control over the pressure applied to the cable inner lead covering.

The CMP E2W range of industrial cable glands is designed and tested to BS 6121:Part 1:1989, meets or surpasses the requirements of EN 50262 :1999, and is produced from Brass grade CuZn39Pb3 (CW614N) to EN12168. Other materials including Aluminium are also available in this standard design.

TECHNICAL DATA	
Type	E2W
Design Specification	BS 6121:Part 1:1989, EN 50262:1999
EN 50262 Mechanical Classifications	Retention = Class B, Impact = Level 8,
EN 50262 Electrical Classifications	Category A without use of an Earth Tag and Category B with an Earth Tag.
GOST R Certificate Number	POCC GB. Г Б 05.H00110
GOST K Certificate Number	KZ7500052.05.01.00063
RoK Permit for Use Number	08-067693
Lloyds Approval Number	01/00171
ABS Approval Number	01-LD 234401-PDA
Continuous Operating Temperature	-60°C to +150°C
Ingress Protection Rating	IP66 (IP67/IP68 also available)
Standard Gland Material	Brass
Alternative Gland Material	Aluminium, Electroless Nickel Plated Brass, Stainless Steel
Seal Material	CMP Formulated Thermoplastic Elastomer
Cable Type	Lead Sheathed & Single Wire Armour (LC/SWA)
Armour Clamping	Detachable Armour Cone & AnyWay Universal Clamping Ring
Sealing Technique	CMP Inner Displacement Seal & Unique CMP "LRS"™ Outer Seal (Load Retention Seal)
Sealing Area(s)	Inner & Outer Sheath
Optional Accessories	Adaptor/Reducer, Earth Tag, Entry Thread Seal, Locknut, Serrated Washer, Shroud

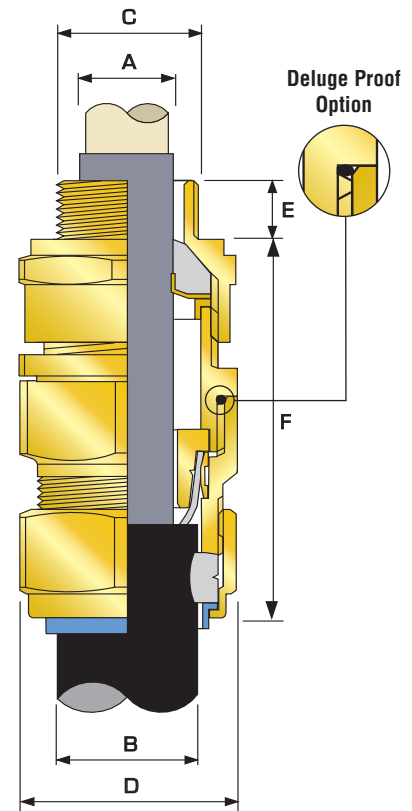

Note: Deluge proof version available

Cable Gland Selection Table

Cable Gland Size	Available Entry Threads 'C'			Minimum Thread Length 'E'	Cable Lead Sheath Diameter 'A'		Overall Cable Diameter 'B'		Armour Range †		Across Flats 'D'	Across Corners 'D'	Nominal Protrusion Length 'F'	Ordering Reference (Brass Metric) #	PVC Shroud Reference*	Cable Gland Weight (Kgs)
	Standard		Option		Min	Max	Min	Max	Min	Max						
	Metric	NPT	NPT													
20S/16	M20	1/2"	3/4"	10.0	3.1	8.7	6.1	11.5	0.9	1.0	24.0	26.6	63.0	20S16E2W1RA	PVC04	0.163
20S	M20	1/2"	3/4"	10.0	6.1	11.7	9.5	15.9	0.9	1.25	24.0	26.6	63.0	20SE2W1RA	PVC04	0.163
20	M20	1/2"	3/4"	10.0	6.5	14.0	12.5	20.9	0.9	1.25	30.5	33.3	67.0	20E2W1RA	PVC06	0.217
25S	M25	3/4"	1"	10.0	11.1	20.0	14.0	22.0	1.25	1.6	37.5	40.5	78.0	25SE2W1RA	PVC09	0.345
25	M25	3/4"	1"	10.0	11.1	20.0	18.2	26.2	1.25	1.6	37.5	40.5	78.0	25E2W1RA	PVC09	0.345
32	M32	1"	1-1/4"	15.0	17.0	26.3	23.7	33.9	1.6	2.0	46.0	51.0	78.0	32E2W1RA	PVC11	0.484
40	M40	1-1/4"	1-1/2"	15.0	22.0	32.2	27.9	40.4	1.6	2.0	55.0	61.0	83.0	40E2W1RA	PVC15	0.700
50S	M50	1-1/2"	2"	15.0	29.5	38.2	35.2	46.7	2.0	2.5	60.0	66.5	78.0	50SE2W1RA	PVC18	0.800
50	M50	2"	2-1/2"	15.0	35.6	44.1	40.4	53.1	2.0	2.5	70.0	78.6	81.0	50E2W1RA	PVC21	0.830
63S	M63	2"	2-1/2"	15.0	40.1	50.0	45.6	59.4	2.0	2.5	75.0	83.2	93.0	63SE2W1RA	PVC23	1.415
63	M63	2-1/2"	3"	15.0	47.2	56.0	54.6	65.9	2.0	2.5	80.0	89.0	95.0	63E2W1RA	PVC25	1.514
75S	M75	2-1/2"	3"	15.0	52.8	62.0	59.0	72.1	2.0	2.5	89.0	101.6	103.0	75SE2W1RA	PVC28	2.199
75	M75	3"	3-1/2"	15.0	59.1	68.0	66.7	78.5	2.0	2.5	99.0	111.1	110.0	75E2W1RA	PVC30	2.770
90	M90	3"	3-1/2"	15.0	66.6	79.4	76.2	90.4	3.15	3.15	114.0	128.6	136.0	90E2W1RA	PVC32	4.478
100	M100	4"	-	15.0	76.0	91.0	89.1	101.5	3.15	4.0	123.0	138.0	145.0	100E2W1RA	150/50HST	4.700
115	M115	-	-	15.0	86.0	98.0	101.3	110.3	3.15	4.0	133.4	147.6	160.0	115E2W1RA	180/60HST	5.300
130	M130	-	-	15.0	97.0	115.0	114.0	123.3	3.15	4.0	146.1	161.9	185.0	130E2W1RA	180/60HST	5.900

All dimensions in millimetres

Note: *LSF Shrouds also available on request. † Alternative armour clamping range available for non-standard armour sizes. Marine approvals including Lloyds, DNV & ABS are also available from CMP Products. # Other thread forms are available.

E1X CABLE GLAND

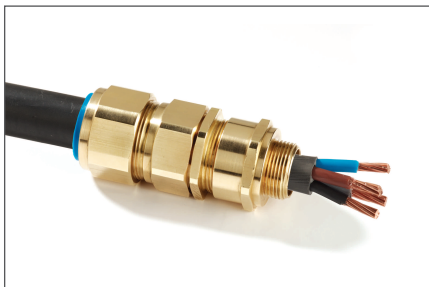

E1X Industrial Cable Gland

CMP E1X type brass indoor and outdoor cable gland for use with all types of Wire Braid Armour, Strip Armour, Pliable Wire Armour & Steel Tape Armour (STA) cable providing an environmental seal on the cable inner bedding and cable outer sheath. The cable gland provides mechanical cable retention and electrical continuity via armour termination. A detachable armour cone and AnyWay universal clamping ring arrangement allows the cable to be easily disconnected from the equipment, for maintenance and change out etc. This feature also facilitates remote make off procedures when the termination is to be conducted in confined spaces or in areas of restricted access. Separate tightening actions for the inner displacement seal and the armour termination affords maximum control over the pressure applied to the cable inner bedding.

The CMP E1X range of industrial cable glands is designed and tested to BS 6121:Part 1:1989, meets or surpasses the requirements of EN 50262 :1999, and is produced from Brass grade CuZn39Pb3 (CW614N) to EN12168. Other materials including Aluminium are also available in this standard design.

TECHNICAL DATA

Type	E1X
Design Specification	BS 6121:Part 1:1989, EN 50262:1999
EN 50262 Mechanical Classifications	Retention = Class B, Impact = Level 8,
EN 50262 Electrical Classifications	Category A without use of an Earth Tag and Category B with an Earth Tag.
GOST R Certificate Number	POCC GB. Г Б 05.H00110
GOST K Certificate Number	KZ7500052.05.01.00063
RoK Permit for Use Number	08-067693
Continuous Operating Temperature	-60°C to +150°C
Ingress Protection Rating	IP66 (IP67/IP68 also available)
Standard Gland Material	Brass
Alternative Gland Material	Electroless Nickel Plated Brass, Stainless Steel, Aluminium
Seal Material	CMP Formulated Thermoplastic Elastomer
Cable Type	Wire Braid Armour, Screened Flexible Wire Braid (e.g. CY / SY), Pliable Wire Armour (PWA), Steel Tape Armour (STA)
Armour Clamping	Detachable Armour Cone & AnyWay Universal Clamping Ring
Sealing Technique	CMP Inner Displacement Seal & Unique CMP "LRS"™ Outer Seal (Load Retention Seal)
Sealing Area(s)	Cable Inner Bedding & Cable Outer Sheath
Optional Accessories	Adaptor/Reducer, Earth Tag, Entry Thread Seal, Locknut, Serrated Washer, Shroud

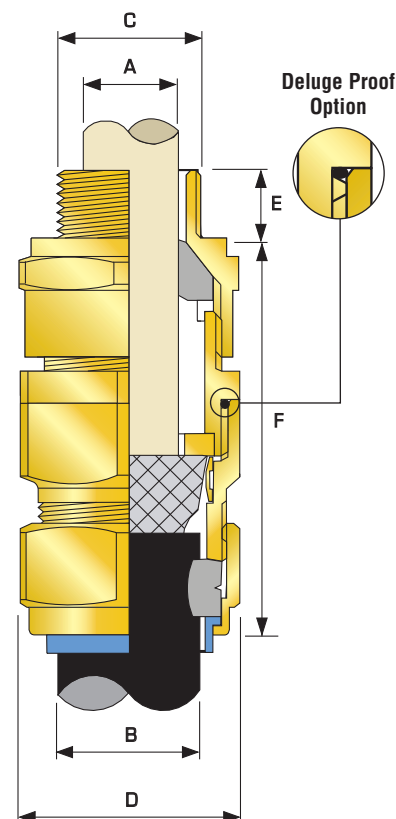

Note: Deluge proof version available

Cable Gland Selection Table

Cable Gland Size	Available Entry Threads 'C'			Minimum Thread Length 'E'	Cable Bedding Diameter 'A'		Overall Cable Diameter 'B'		Armour Range		Across Flats 'D'	Across Corners 'D'	Nominal Protrusion Length 'F'	Ordering Reference (Brass Metric) #	PVC Shroud Reference*	Cable Gland Weight (Kgs)
	Standard	Option			Min	Max	Min	Max	Min	Max	Max	Max				
		Metric	NPT													
20S16	M20	1/2"	3/4"	10.0	3.1	8.7	6.1	11.5	0.0	1.0	24.0	26.6	63.0	20S16E1X1RA	PVC04	0.163
20S	M20	1/2"	3/4"	10.0	6.1	11.7	9.5	15.9	0.0	1.0	24.0	26.6	63.0	20SE1X1RA	PVC04	0.163
20	M20	1/2"	3/4"	10.0	6.5	14.0	12.5	20.9	0.0	1.0	30.5	33.3	67.0	20E1X1RA	PVC06	0.217
25S	M25	3/4"	1"	10.0	11.1	20.0	14.0	22.0	0.0	1.0	37.5	40.5	78.0	25SE1X1RA	PVC09	0.345
25	M25	3/4"	1"	10.0	11.1	20.0	18.2	26.2	0.0	1.0	37.5	40.5	78.0	25E1X1RA	PVC09	0.345
32	M32	1"	1-1/4"	15.0	17.0	26.3	23.7	33.9	0.0	1.0	46.0	51.0	78.0	32E1X1RA	PVC11	0.484
40	M40	1-1/4"	1-1/2"	15.0	22.0	32.2	27.9	40.4	0.0	1.0	55.0	61.0	83.0	40E1X1RA	PVC15	0.700
50S	M50	1-1/2"	2"	15.0	29.5	38.2	35.2	46.7	0.0	1.0	60.0	66.5	78.0	50SE1X1RA	PVC18	0.800
50	M50	2"	2-1/2"	15.0	35.6	44.1	40.4	53.1	0.0	1.0	70.0	78.6	81.0	50E1X1RA	PVC21	0.830
63S	M63	2"	2-1/2"	15.0	40.1	50.0	45.6	59.4	0.0	1.0	75.0	83.2	93.0	63SE1X1RA	PVC23	1.415
63	M63	2-1/2"	3"	15.0	47.2	56.0	54.6	65.9	0.0	1.0	80.0	89.0	95.0	63E1X1RA	PVC25	1.514
75S	M75	2-1/2"	3"	15.0	52.8	62.0	59.0	72.1	0.0	1.0	89.0	101.6	103.0	75SE1X1RA	PVC28	2.199
75	M75	3"	3-1/2"	15.0	59.1	68.0	66.7	78.5	0.0	1.0	99.0	111.1	110.0	75E1X1RA	PVC30	2.770
90	M90	3"	3-1/2"	15.0	66.6	79.4	76.2	90.4	0.0	1.6	114.0	128.6	136.0	90E1X1RA	PVC32	4.478
100	M100	4"	-	15.0	76.0	91.0	89.1	101.5	0.0	1.6	123.0	138.0	145.0	100E1X1RA	150/50HST	4.700
115	M115	-	-	15.0	86.0	98.0	101.3	110.3	0.0	1.6	133.4	147.6	160.0	115E1X1RA	180/60HST	5.300
130	M130	-	-	15.0	97.0	115.0	114.0	123.3	0.0	1.6	146.1	161.9	185.0	130E1X1RA	180/60HST	5.900

All dimensions in millimetres

Note: *LSF Shrouds also available on request. Marine approvals including Lloyds, DNV & ABS are also available from CMP Products. # Other thread forms are available.

E2X CABLE GLAND

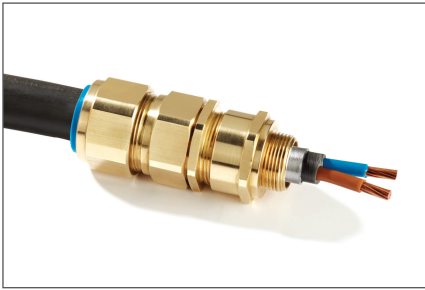

E2X Industrial Cable Gland

CMP E2X type brass indoor and outdoor cable gland for use with all types of Lead Sheathed and Wire Braid Armour, Strip Armour, Pliable Wire Armour & Steel Tape Armour (STA) cable providing an environmental seal on the cable inner lead sheath and cable outer sheath. The cable gland provides mechanical cable retention and electrical continuity via the armour termination and also earth bonding of the inner lead covering or lead sheath. A detachable armour cone and AnyWay universal clamping ring arrangement allows the cable to be easily disconnected from the equipment, for maintenance and change out etc. This feature also facilitates remote make off procedures when the termination is to be conducted in confined spaces or in areas of restricted access. Separate tightening actions for the inner displacement seal and the armour termination affords maximum control over the pressure applied to the cable inner bedding.

The CMP E2X range of industrial cable glands is designed and tested to BS 6121:Part 1:1989, meets or surpasses the requirements of EN 50262 :1999, and is produced from Brass grade CuZn39Pb3 (CW614N) to EN12168. Other materials including Aluminium are also available in this standard design.

TECHNICAL DATA	
Type	E2X
Design Specification	BS 6121:Part 1:1989, EN 50262:1999
EN 50262 Mechanical Classifications	Retention = Class B, Impact = Level 8,
EN 50262 Electrical Classifications	Category A without use of an Earth Tag and Category B with an Earth Tag.
GOST R Certificate Number	POCC GB. ГЕ 05.H00110
GOST K Certificate Number	KZ7500052.05.01.00063
RoK Permit for Use Number	08-067693
Continuous Operating Temperature	-60°C to +150°C
Ingress Protection Rating	IP66 (IP67/IP68 also available)
Standard Gland Material	Brass
Alternative Gland Material	Electroless Nickel Plated Brass, Stainless Steel, Aluminium
Seal Material	CMP Formulated Thermoplastic Elastomer
Cable Type	Lead Sheathed & Wire Braid Armour, Lead Sheathed & Steel Tape Armour (LC/STA)
Armour Clamping	Detachable Armour Cone & AnyWay Universal Clamping Ring
Sealing Technique	CMP Inner Displacement Seal & Unique CMP "LRS"™ Outer Seal (Load Retention Seal)
Sealing Area(s)	Cable Inner Lead Sheath and Cable
Optional Accessories	Adaptor/Reducer, Earth Tag, Entry Thread Seal, Locknut, Serrated Washer, Shroud

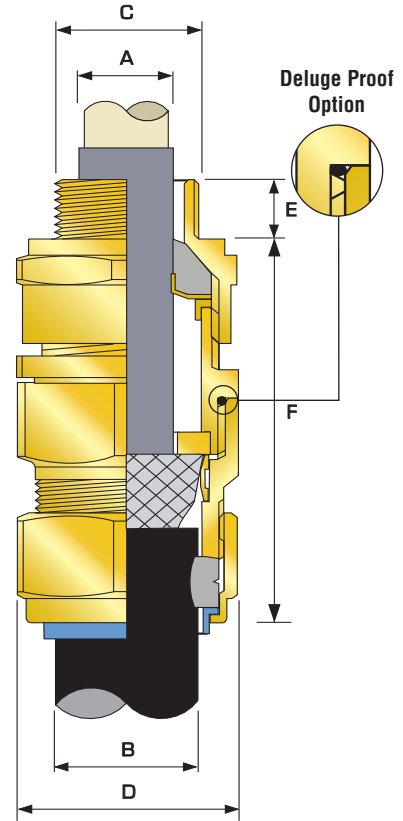

Note: Deluge proof version available

Cable Gland Selection Table

Cable Gland Size	Available Entry Threads 'C'			Minimum Thread Length 'E'	Cable Lead Sheath Diameter 'A'		Overall Cable Diameter 'B'		Armour Range		Across Flats 'D'	Across Corners 'D'	Nominal Protrusion Length 'F'	Ordering Reference (Brass Metric) #	PVC Shroud Reference*	Cable Gland Weight (Kgs)
	Standard	Option			Min	Max	Min	Max	Min	Max	Max	Max				
		Metric	NPT													
20S16	M20	1/2"	3/4"	10.0	3.1	8.7	6.1	11.5	0.0	1.0	24.0	26.6	63.0	20S16E2X1RA	PVC04	0.163
20S	M20	1/2"	3/4"	10.0	6.1	11.7	9.5	15.9	0.0	1.0	24.0	26.6	63.0	20SE2X1RA	PVC04	0.163
20	M20	1/2"	3/4"	10.0	6.5	14.0	12.5	20.9	0.0	1.0	30.5	33.3	67.0	20E2X1RA	PVC06	0.217
25S	M25	3/4"	1"	10.0	11.1	20.0	14.0	22.0	0.0	1.0	37.5	40.5	78.0	25SE2X1RA	PVC09	0.345
25	M25	3/4"	1"	10.0	11.1	20.0	18.2	26.2	0.0	1.0	37.5	40.5	78.0	25E2X1RA	PVC09	0.345
32	M32	1"	1-1/4"	15.0	17.0	26.3	23.7	33.9	0.0	1.0	46.0	51.0	78.0	32E2X1RA	PVC11	0.484
40	M40	1-1/4"	1-1/2"	15.0	22.0	32.2	27.9	40.4	0.0	1.0	55.0	61.0	83.0	40E2X1RA	PVC15	0.700
50S	M50	1-1/2"	2"	15.0	29.5	38.2	35.2	46.7	0.0	1.0	60.0	66.5	78.0	50SE2X1RA	PVC18	0.800
50	M50	2"	2-1/2"	15.0	35.6	44.1	40.4	53.1	0.0	1.0	70.0	78.6	81.0	50E2X1RA	PVC21	0.830
63S	M63	2"	2-1/2"	15.0	40.1	50.0	45.6	59.4	0.0	1.0	75.0	83.2	93.0	63SE2X1RA	PVC23	1.415
63	M63	2-1/2"	3"	15.0	47.2	56.0	54.6	65.9	0.0	1.0	80.0	89.0	95.0	63E2X1RA	PVC25	1.514
75S	M75	2-1/2"	3"	15.0	52.8	62.0	59.0	72.1	0.0	1.0	89.0	101.6	103.0	75SE2X1RA	PVC28	2.199
75	M75	3"	3-1/2"	15.0	59.1	68.0	66.7	78.5	0.0	1.0	99.0	111.1	110.0	75E2X1RA	PVC30	2.770
90	M90	3"	3-1/2"	15.0	66.6	79.4	76.2	90.4	0.0	1.6	114.0	128.6	136.0	90E2X1RA	PVC32	4.478
100	M100	4"	-	15.0	76.0	91.0	89.1	101.5	0.0	1.6	123.0	138.0	145.0	100E2X1RA	150/50HST	4.700
115	M115	-	-	15.0	86.0	98.0	101.3	110.3	0.0	1.6	133.4	147.6	160.0	115E2X1RA	180/60HST	5.300
130	M130	-	-	15.0	97.0	115.0	114.0	123.3	0.0	1.6	146.1	161.9	185.0	130E2X1RA	180/60HST	5.900

All dimensions in millimetres

Note: *LSF Shrouds also available on request. Marine approvals including Lloyds, DNV & ABS are also available from CMP Products. # Other thread forms are available.

A2DG CABLE GLAND

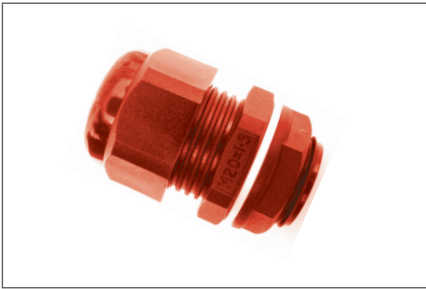

A2DG Dome Top Cable Gland

CMP A2DG type indoor and outdoor non-metallic Dome Cap cable gland for use with all types of Unarmoured cables, providing an environmental seal on the cable outer sheath. The A2DG cable glands are available in various colours and are supplied complete with sealing washer and locknut. Standard thread forms are metric to EN 60423.

Standard versions are produced in Low Smoke and Fume (LSF) polymeric materials with UL 94 V2 rating. Alternative versions are available in Red coloured Flame Retardant, Low Smoke and Fume (LSF) and Halogen Free polymeric material with UL 94 V0 rating.

TECHNICAL DATA	
Type	A2DG Dome Cable Gland
Design Specification	EN 50262:1999
Ingress Protection Rating	IP68 to a depth of 40 metres
Material	Low Smoke & Fume Polymeric Material
Continuous Operating Temperature Range	-20°C to +80°C, Intermittent up to 120°C
Available Colours	Black, White, Bright Red to Ral 3020, Light Grey to Ral 7035 and Mid Grey to Ral 7001
Standard Cable Gland Flammability Rating	UL 94 V2
Alternative Cable Gland Flammability Rating	UL 94 V0 (Red Colour Only)
Cable Type	Unarmoured
Sealing Area	Cable Outer Sheath
Accessories	Locknut & Sealing Washer (included)

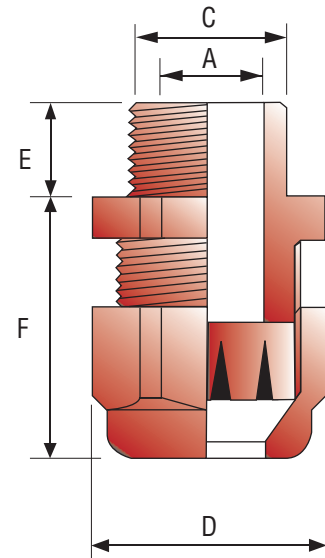

Substitute X for the colour Black=BLK, Red=R, White=W, Light Grey=LG, Mid Grey=MG

Cable Gland Selection Table

Standard Cable Gland Range								
Ordering Reference	Qty per Box	Thread Diameter 'C'	Thread Length 'E'	Overall Cable Diameter 'A'		Protrusion Length 'F'	Across Flats 'D'	Across Corners 'D'
				Min	Max		Max	Max
A2DG12S-X	100	M12	8.0	3.0	6.5	22.0	11.0	17.0
A2DG16S-X	100	M16	11.0	3.0	7.0	30.0	22.0	24.0
A2DG16L-X	100	M16	11.0	5.0	10.0	30.0	22.0	24.0
A2DG20S-X	100	M20	12.5	4.0	9.0	30.0	24.0	26.4
A2DG20M-X	100	M20	12.5	6.0	12.0	31.0	24.0	26.4
A2DG20L-X	100	M20	12.5	10.0	14.0	31.0	27.0	32.5
A2DG25L-X	100	M25	12.0	13.0	18.0	36.0	33.0	36.0
A2DG32S-X	75	M32	15.0	18.0	25.0	42.0	42.0	47.0
A2DG40S-X	60	M40	15.0	22.0	32.0	50.0	53.0	60.0
A2DG50S-X	50	M50	15.0	30.0	38.0	55.0	60.0	67.0
A2DG63S-X	50	M63	15.0	34.0	44.0	56.0	70.0	78.0

All dimensions in millimetres

A2 200 HEX CABLE GLAND

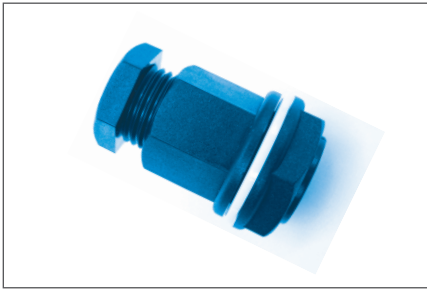

A2 200 Hex Head Series Cable Gland

CMP A2 200 type indoor and outdoor non-metallic Hex Head cable gland for use with all types of Unarmoured cables, providing an environmental seal on the cable outer sheath. The A2 200 Hex Head cable glands are available in various colours and are supplied complete with sealing washer and locknut. Standard thread forms are metric to EN 60423.

Standard versions are produced in Low Smoke and Fume (LSF) polymeric materials with UL 94 V2 rating.

Alternative versions are available in Red coloured Flame Retardant, Low Smoke and Fume (LSF) and Halogen Free polymeric material with UL 94 V0 rating.

TECHNICAL DATA	
Type	A2 200 Hex Head
Design Specification	EN 50262:1999
Ingress Protection Rating	IP55
Material	Low Smoke & Fume (LSF) Polymeric Material
Continuous Operating Temperature Range	-20°C to +80°C, Intermittent up to 120°C
Available Colours	Black, White, Bright Red to Ral 3020, Light Grey to Ral 7035 and Mid Grey to Ral 7001
Standard Cable Gland Flammability Rating	UL 94 V2
Alternative Cable Gland Flammability Rating	UL 94 V0 (Red Colour Only)
Cable Type	Unarmoured
Sealing Area	Cable Outer Sheath
Accessories	Locknut & Sealing Washer (included)

Substitute X for the colour Black=BLK, Red=R, White=W, Light Grey=LG, Mid Grey=MG

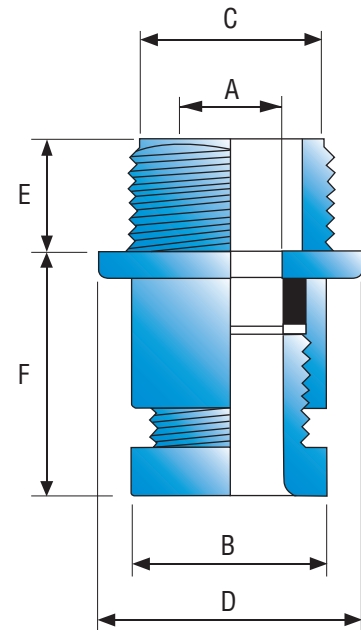

Cable Gland Selection Table

Standard Cable Gland Range								
Ordering Reference	Body Size	Thread Diameter 'C'	Min Thread Length 'E'	Overall Cable Diameter 'A'		Protrusion Length 'F'	Across Flats 'B'	Envelope Diameter 'D'
				Min	Max		Max	
A2 - 248 - X	16	M16	11.0	4.0	7.0	24.0	19.0	22.5
A2 - 250 - X	16	M16	11.0	7.0	10.5	24.0	19.0	22.5
A2 - 249 - X	16	M20	11.0	4.0	7.0	27.0	19.0	25.4
A2 - 251 - X	16	M20	11.0	7.0	10.5	27.0	19.0	25.4
A2 - 252 - X	20	M20	11.0	8.0	13.0	31.0	22.5	26.8
A2 - 264 - X	20	M25	11.0	4.0	7.0	31.0	23.0	32.5
A2 - 265 - X	20	M25	11.0	7.0	10.5	31.0	23.0	32.5
A2 - 253 - X	20	M25	11.0	8.0	13.0	31.0	23.0	32.5
A2 - 254 - X	25	M25	11.0	13.0	18.0	32.5	28.0	32.5
A2 - 255 - X	32	M32	13.0	18.0	24.5	38.0	36.0	42.0

All dimensions in millimetres



CMP SOLO - LOW SMOKE & FUME - HALOGEN FREE PRODUCTS

SOLO LOW SMOKE & FUME RANGE

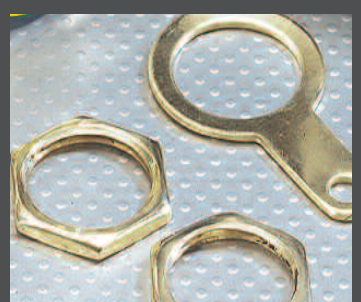
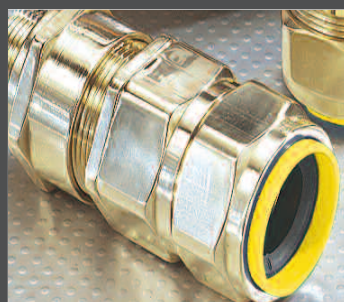



■ APPLICATION

The outstanding safety benefits of low smoke and fume (LSF) or halogen free cables materials have already led to their increased use in areas considered to be potentially at risk in situations of fire hazard. Typical examples are in tunnels, deep bore underground metro systems, and public buildings where the risk of smoke inhalation, in the event of fire, is at it's greatest. The CMP SOLO LSF range of cable glands and accessories meets the most stringent requirements and provide a single, simple solution for specifiers and users in meeting LSF and Halogen Free requirements.

■ PRODUCTS

The CMP SOLO LSF option can be provided for all types of cable glands shown in this catalogue.

■ SPECIFICATIONS & APPROVALS

Designed and tested for compliance with EN 50267-2-1, the Test on Gases Evolved During Combustion of Materials applied to cables under fire conditions.

Meets the requirements of London Underground Ltd Fire Safety Regulations.

■ TO ORDER GLAND KITS

Add LSF2RA after the gland size and type e.g. 25CWLSF2RA to denote that a Gland Kit is required.

BW SOLO LSF Industrial Cable Gland Kit

Brass indoor cable gland kit for all types of SWA cable, providing mechanical cable retention, and electrical continuity via armour wire termination. The cable gland kit includes CMP SOLO LSF Shrouds.

TECHNICAL DATA

Type	BW SOLO-Kit
Cable Gland Kit Contents	Up to & including size 25 - 2 cable glands, 2 locknuts, 2 earth tags & 2 LSF shrouds. Size 32 & above - 1 cable gland, 1 locknut, 1 earth tag & 1 LSF shroud.
Design Specification	BS6121 : 2005
Cable Gland Material	Brass
Continuous Operating Temperature	-60° C to +150° C
Cable Type	Single Wire Armour
Armour Clamping	Two Part Armour Lock



CW SOLO LSF Industrial Cable Gland Kit

Brass indoor and outdoor cable gland kit for all types of SWA cable, providing environmental seal on the cable outer sheath. The cable gland also provides mechanical cable retention, and electrical continuity via armour wire termination. The cable gland kit includes CMP SOLO LSF shrouds and seals.

TECHNICAL DATA

Type	CW SOLO-Kit
Cable Gland Kit Contents	Up to & including size 25 - 2 cable glands, 2 locknuts, 2 earth tags & 2 LSF shrouds. Size 32 & above - 1 cable gland, 1 locknut, 1 earth tag & 1 LSF shroud.
Design Specification	BS6121 : Part 1 : 1989, EN50262:1999
Cable Gland Material	Brass
Continuous Operating Temperature	-60° C to +150° C
Cable Type	Single Wire Armour
Armour Clamping	Detachable Armour Cone & AnyWay Universal Clamping Ring



Note : Ferrule colour coded gold for ease of LSF identification.

Cable Gland Selection Table

Cable Gland Size	Metric Entry Thread	Minimum Thread Length	BW SOLO		Ordering Reference	LSF Shroud Reference	CW SOLO			Ordering Reference	LSF Shroud Ref.	Armour Wire Diameter
			Cable Bedding Diameter	Overall Cable Diameter			Cable Bedding Diameter	Overall Cable Diameter				
			Max.	Max.				Max.-	Min			
20S/16	M20	15.0	-	-	-	-	8.7	6.1	11.5	20S16CWLSF2RA	LSF02	0.9
20S	M20	10.0	11.7	16.1	20SBWLSF2RA	LSF01	11.7	9.5	15.9	20SCWLSF2RA	LSF04	0.9/1.25
20	M20	10.0	14.0	21.1	20BWLSF2RA	LSF05	14.0	12.5	20.9	20CWLSF2RA	LSF06	0.9/1.25
25	M25	10.0	20.0	27.4	25BWLSF2RA	LSF07	20.0	18.2	26.2	25CWLSF2RA	LSF09	1.25/1.6
32	M32	10.0	26.3	34.4	32BWLSF2RA	LSF10	26.3	23.7	33.9	32CWLSF2RA	LSF11	1.6/2.0
40	M40	15.0	26.3	42.4	40BWLSF2RA	LSF12	32.2	27.9	40.4	40CWLSF2RA	LSF15	1.6/2.0
50S	M50	15.0	38.2	50.1	50SBWLSF2RA	LSF16	38.2	35.2	46.7	50SCWLSF2RA	LSF18	2.0/2.5
50	M50	15.0	44.1	55.7	50BWLSF2RA	LSF19	44.1	40.4	53.1	50CWLSF2RA	LSF21	2.0/2.5
63S	M63	15.0	50.0	62.4	63SBWLSF2RA	LSF22	50.0	45.6	59.4	63SCWLSF2RA	LSF23	2.5
63	M63	15.0	56.0	68.2	63BWLSF2RA	LSF24	56.0	54.6	65.9	63CWLSF2RA	LSF25	2.5
75S	M75	15.0	62.0	76.8	75SBWLSF2RA	LSF27	62.0	59.0	72.1	75SCWLSF2RA	LSF28	2.5
75	M75	15.0	68.0	82.9	75BWLSF2RA	LSF29	68.0	66.7	78.5	75CWLSF2RA	LSF30	2.5/3.15

All dimensions in millimetres

E1W SOLO LSF Industrial Cable Gland Kit

Cable gland kit for all types of SWA cable, providing environmental seal on the cable Inner Bedding and Outer Sheaths. The cable gland also provides mechanical cable retention, and electrical continuity via armour wire termination. The cable gland kit includes CMP SOLO LSF shrouds and seals.



TECHNICAL DATA

Type	E1W SOLO-Kit
Cable Gland Kit Contents	Up to & including size 25 - 2 cable glands, 2 locknuts, 2 earth tags & 2 LSF shrouds. Size 32 & above - 1 cable gland, 1 locknut, 1 earth tag & 1 LSF shroud.
Design Specification	BS6121 : Part 1 : 1989, EN50262:1999
Cable Gland Material	Brass
Continuous Operating Temperature	-60° C to +150° C
Cable Type	Single Wire Armour
Armour Clamping	Detachable Armour Cone & AnyWay Universal Clamping Ring

Note : Ferrule colour coded gold for ease of LSF identification..

A2 SOLO LSF Industrial Cable Gland Kit

Cable gland kit for all types of Unarmoured cable, providing a seal on the Cable Outer Sheath. The cable gland kit includes CMP SOLO LSF shrouds and seals.



TECHNICAL DATA

Type	A2 SOLO-Kit
Cable Gland Kit Contents	Up to & including size 25 - 2 cable glands, 2 locknuts, 2 earth tags & 2 LSF shrouds. Size 32 & above - 1 cable gland, 1 locknut, 1 earth tag & 1 LSF shroud.
Design Specification	BS6121 : Part 1 : 1989, EN50262:1999
Cable Gland Material	Brass
Continuous Operating Temperature	-60° C to +150° C
Cable Type	Unarmoured

Cable Gland Selection Table

Cable Gland Size	Metric Entry Thread	Minimum Thread Length	A2 SOLO		Ordering Reference	LSF Shroud Reference	E1W SOLO				Ordering Reference	LSF Shroud Reference	Armour Wire Diameter
			Overall Cable Diameter				Cable Bedding Diameter		Overall Cable Diameter				
			Min	Max			Min	Max	Min	Max			
20S/16	M20	15.0	3.1	8.7	20S16A2LSF2RA	LSF01	3.1	8.7	6.1	11.5	20S16E1WLSF2RA	LSF02	0.9
20S	M20	10.0	6.1	11.7	20SA2LSF2RA	LSF03	6.1	11.7	9.5	15.9	20SE1WLSF2RA	LSF04	0.9/1.25
20	M20	10.0	6.5	14.0	20A2LSF2RA	LSF05	6.5	14.0	12.5	20.9	20E1WLSF2RA	LSF06	0.9/1.25
25	M25	10.0	11.1	20.0	25A2LSF2RA	LSF08	11.1	20.0	18.2	26.2	25E1WLSF2RA	LSF09	1.25/1.6
32	M32	10.0	17.0	26.3	32A2LSF2RA	LSF10	17.0	26.3	23.7	33.9	32E1WLSF2RA	LSF11	1.6/2.0
40	M40	15.0	22.0	32.2	40A2LSF2RA	LSF12	22.0	32.2	27.9	40.4	40E1WLSF2RA	LSF15	1.6/2.0
50S	M50	15.0	29.5	38.2	50SA2LSF2RA	LSF14	29.5	38.2	35.2	46.7	50SE1WLSF2RA	LSF18	2.0/2.5
50	M50	15.0	35.6	44.1	50A2LSF2RA	LSF17	35.6	44.1	40.4	53.1	50E1WLSF2RA	LSF21	2.0/2.5
63S	M63	15.0	40.1	50.0	63SA2LSF2RA	LSF20	40.1	50.0	45.6	59.4	63SE1WLSF2RA	LSF23	2.5
63	M63	15.0	47.2	56.0	63A2LSF2RA	LSF22	47.2	56.0	54.6	65.9	63E1WLSF2RA	LSF25	2.5
75S	M75	15.0	52.8	62.0	75SA2LSF2RA	LSF24	52.8	62.0	59.0	72.1	75SE1WLSF2RA	LSF28	2.5
75	M75	15.0	59.1	68.0	75A2LSF2RA	LSF26	59.1	68.0	66.7	78.5	75E1WLSF2RA	LSF30	2.5/3.15

All dimensions in millimetres



CIEL CAST INTEGRAL EARTH LUG

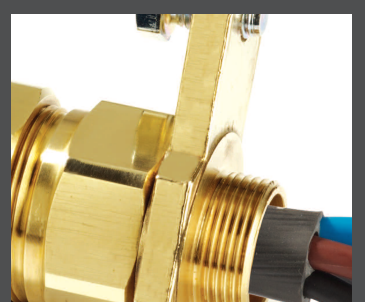
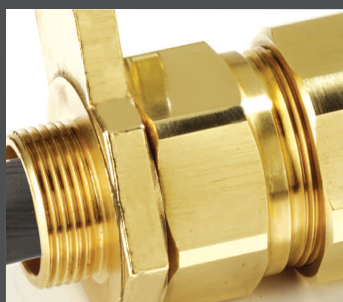
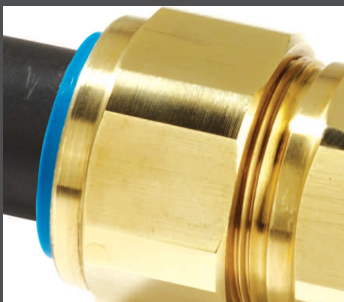



■ APPLICATION

The CMP Cast Integral Earth Lug (CIEL) concept is intended for external earth connections where it is essential to maintain critical earthing under high level short circuit fault conditions. It is designed to meet I.E.E. earthing regulations and because of its unique design, is particularly suitable for MV and HV installations where low resistance earthing is essential.

■ TESTING

CMP CIEL cable glands have been subjected to independent third party short circuit tests to determine their short circuit fault current ratings resulting in the following :-

Symmetrical Fault Current (kA) for 1 second
 26.0 kA for cable gland sizes up to 40
 43.0 kA for cable gland sizes 50S and above

■ PRODUCTS

The CMP cast integral earth lug (CIEL) option is available in various gland types including BWL-CIEL, CW-CIEL, E1W-CIEL and E2W-CIEL. Other options are available on request including versions for hazardous area installations, such as E1FW-CIEL & E2FW-CIEL.

■ HOW TO ORDER

Please state cable gland type and size e.g. 25CWC1RA, where the abbreviation letter C is used to identify the product type CIEL. Refer to specific catalogue page.

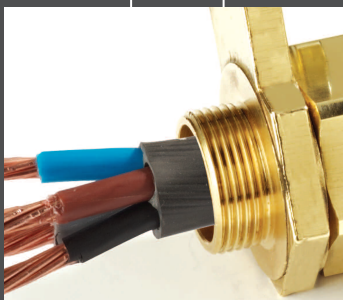

BWL CIEL CABLE GLAND

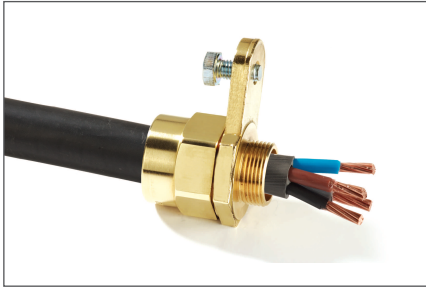

BWL-CIEL Industrial Cable Gland

Brass indoor gland for use with all types of SWA cable providing mechanical retention and electrical continuity via armourwire termination. Complete with CMP unique Cast Integral Earth Lug (CIEL) concept. This is particular suitable for H.V. systems where a high level of protection against fault currents is required.

TECHNICAL DATA

Type	BWL CIEL
Design Specification	BS 6121:2005
EN 50262 Mechanical Classifications	Retention = Class B, Impact = Level 8,
EN 50262 Electrical Classifications	Category C
GOST R Certificate Number	POCC GB. ГБ05.H00110
GOST K Certificate Number	KZ7500052.05.01.00063
RoK Permit for Use Number	08-067693
Continuous Operating Temperature	-60°C to +150°C
Ingress Protection Rating	IP2X
Standard Gland Material	Brass
Alternative Gland Material	Electroless Nickel Plated Brass, Stainless Steel, Aluminium
Cable Type	Single Wire Armour (SWA), Aluminium Wire Armour (AWA)
Armour Clamping	Detachable Armour Cone and Anyway Universal Clamping Ring
Optional Accessories	Adaptor/Reducer, Entry Thread Seal, Locknut, Serrated Washer, Shroud

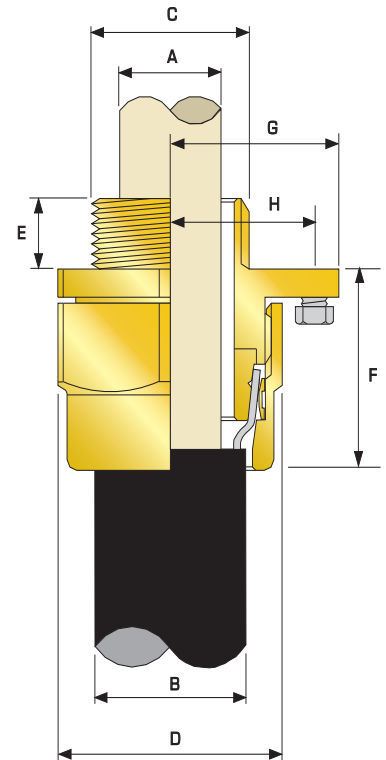

Cable Gland Selection Table

Cable Gland Size	Entry Thread 'C'	Minimum Thread Length 'E'	Cable Bedding Diameter 'A'		Overall Cable Diameter 'B'		Armour Range †		Nominal Across Flats 'D'	Nominal Across Corners 'D'	Nominal Protusion Length 'F'	Nominal Radius Dimension		CIEL Earth Bolt Size	Earth Fault Current Rating (kA)	Ordering Reference (Brass Metric)	PVC Shroud Reference*	Cable Gland Weight (Kgs)
			Max	Max	Min	Max	Max	Max				'H'	'G'					
20S	M20	10.0	11.7	15.9	0.9	1.25	24.0	26.6	26.0	28.6	38.6	M8	26.0	20SBWLC1RA	PVC04	0.126		
20	M20	10.0	14.0	20.9	0.9	1.25	30.5	33.3	34.0	31.8	41.8	M8	26.0	20BWLC1RA	PVC06	0.140		
25	M25	10.0	20.0	26.2	1.25	1.6	37.5	40.5	36.0	38.1	50.8	M8	26.0	25BWLC1RA	PVC09	0.220		
32	M32	10.0	26.3	33.9	1.6	2.0	46.0	51.0	38.0	41.3	54.0	M10	26.0	32BWLC1RA	PVC11	0.300		
40	M40	15.0	32.2	40.4	1.6	2.0	55.0	61.0	40.0	50.8	69.0	M12	26.0	40BWLC1RA	PVC15	0.430		
50S	M50	15.0	38.2	46.7	2.0	2.5	60.0	66.5	40.0	57.2	75.0	M12	43.0	50SBWLC1RA	PVC18	0.490		
50	M50	15.0	44.1	53.1	2.0	2.5	70.0	78.6	42.0	60.3	80.0	M12	43.0	50BWLC1RA	PVC21	0.460		
63S	M63	15.0	50.0	59.4	2.0	2.5	75.0	83.2	48.0	70.0	90.0	M12	43.0	63SBWLC1RA	PVC23	0.900		
63	M63	15.0	56.0	65.9	2.0	2.5	80.0	89.0	48.0	70.0	90.0	M12	43.0	63BWLC1RA	PVC25	1.100		
75S	M75	15.0	62.0	72.1	2.0	2.5	89.0	101.6	54.0	76.2	97.0	M12	43.0	75SBWLC1RA	PVC28	1.536		
75	M75	15.0	68.0	78.5	2.0	2.5	99.0	111.1	54.0	89.0	108.0	M12	43.0	75BWLC1RA	PVC30	1.990		
90	M90	15.0	80.0	90.4	3.15	3.15	114.0	128.6	59.0	95.3	112.0	M12	43.0	90BWLC1RA	PVC32	2.942		
100	M100	15.0	91.0	101.5	3.15	3.15	123.0	136.0	80.0	95.3	112.0	M12	43.0	100BWLC1RA	150/50HST	3.042		
115	M115	15.0	98.0	110.3	3.15	3.15	133.4	147.8	98.0	95.3	112.0	M12	43.0	115BWLC1RA	180/60HST	3.142		
130	M130	15.0	115.0	123.3	3.15	3.15	146.1	146.1	110.0	95.3	112.0	M12	43.0	130BWLC1RA	180/60HST	3.242		

All dimensions in millimetres

Note: *LSF Shrouds also available on request. †Alternative armour clamping range available for non-standard armour sizes. Marine approvals including Lloyds, DNV & ABS are also available from CMP Products.

CW CIEL CABLE GLAND

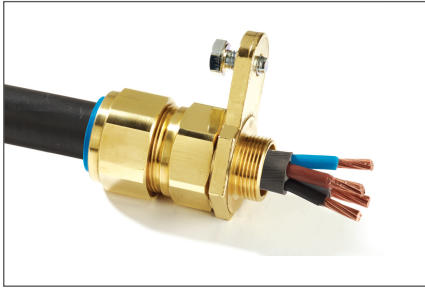

CW-CIEL Industrial Cable Gland

Cable gland for use with all types of SWA cable providing an IP66 environmental seal onto the cable outer sheath. The cable gland being suitable for armoured cables, provides mechanical retention and electrical continuity via armour wire termination. The comes complete with CMP unique Cast Integral Earth Lug (CIEL) concept. This is particular suitable for H.V. systems where a high level of protection against fault currents is required.

TECHNICAL DATA	
Type	CW CIEL
Design Specification	BS 6121:Part 1:1989, EN 50262
EN 50262 Mechanical Classifications	Retention = Class B, Impact = Level 8,
EN 50262 Electrical Classifications	Category C
GOST R Certificate Number	POCC GB. ГБ 05.H00110
GOST K Certificate Number	KZ7500052.05.01.00063
RoK Permit for Use Number	08-067693
Continuous Operating Temperature	-60°C to +150°C
Ingress Protection Rating	IP66
Standard Gland Material	Brass
Alternative Gland Material	Electroless Nickel Plated Brass, Aluminium
Seal Material	CMP Formulated Thermoplastic Elastomer
Cable Type	Single Wire Armour (SWA), Aluminium Wire Armour (AWA)
Armour Clamping	Detachable Armour Cone & AnyWay Universal Clamping Ring
Sealing Technique	Unique CMP "LRS"™ Outer Seal (Load Retention Seal)
Sealing Area(s)	Cable Outer Sheath
Optional Accessories	Adaptor/Reducer, Entry Thread Seal, Locknut, Serrated Washer, Shroud

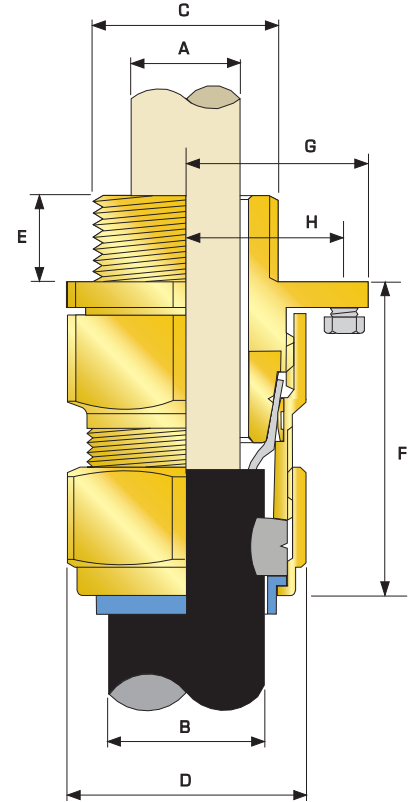

Cable Gland Selection Table

Cable Gland Size	Entry Thread 'C'	Minimum Thread Length 'E'	Cable Bedding Diameter 'A'		Overall Cable Diameter 'B'		Armour Range †		Nominal Across Flats 'D'	Nominal Across Corners 'D'	Nominal Protrusion Length 'F'	Nominal Radius Dimension		CIEL Earth Bolt Size	Earth Fault Current Rating (kA)	Ordering Reference (Brass Metric)	PVC Shroud Reference*	Cable Gland Weight (Kgs)
			Max	Min	Min	Max	Min	Max				'H'	'G'					
20S	M20	10.0	11.7	9.5	15.9	0.9	1.25	24.0	26.6	58.5	48.0	38.6	M8	26.0	20SCWC1RA	PVC04	0.140	
20	M20	10.0	14.0	12.5	20.9	0.9	1.25	30.5	33.3	60.5	55.0	41.8	M8	26.0	20CWC1RA	PVC06	0.180	
25S	M25	10.0	20.0	14.0	22.0	1.25	1.6	37.5	40.5	67.5	60.0	-	M8	26.0	25SCWC1RA	PVC09	0.257	
25	M25	10.0	20.0	18.2	26.2	1.25	1.6	37.5	40.5	67.5	60.0	50.8	M8	26.0	25CWC1RA	PVC09	0.257	
32	M32	10.0	26.3	23.7	33.9	1.6	2.0	46.0	51.0	69.5	60.0	54.0	M10	26.0	32CWC1RA	PVC11	0.376	
40	M40	15.0	32.2	27.9	40.4	1.6	2.0	55.0	61.0	78.0	60.0	69.0	M12	26.0	40CWC1RA	PVC15	0.630	
50S	M50	15.0	38.2	35.2	46.7	2.0	2.5	60.0	66.5	75.5	62.0	75.0	M12	43.0	50SCWC1RA	PVC18	0.757	
50	M50	15.0	44.1	40.4	53.1	2.0	2.5	70.0	78.6	80.5	76.0	80.0	M12	43.0	50CWC1RA	PVC21	0.862	
63S	M63	15.0	50.0	45.6	59.4	2.0	2.5	75.0	83.2	91.5	76.0	90.0	M12	43.0	63SCWC1RA	PVC23	1.390	
63	M63	15.0	56.0	54.6	65.9	2.0	2.5	80.0	89.0	92.0	86.0	90.0	M12	43.0	63CWC1RA	PVC25	1.360	
75S	M75	15.0	62.0	59.0	72.1	2.0	2.5	89.0	101.6	99.0	88.0	97.0	M12	43.0	75SCWC1RA	PVC28	2.307	
75	M75	15.0	68.0	66.7	78.5	2.0	2.5	99.0	111.1	102.0	101.0	108.0	M12	43.0	75CWC1RA	PVC30	2.909	
90	M90	15.0	80.0	76.2	90.4	3.15	3.15	114.0	128.6	120.0	126.0	112.0	M12	43.0	90CWC1RA	PVC32	3.858	
100	M100	15.0	91.0	89.1	101.5	3.15	3.15	123.0	136.0	150.0	126.0	112.0	M12	43.0	100CWC1RA	150/50HST	4.958	
115	M115	15.0	98.0	101.3	110.3	3.15	3.15	133.4	147.8	170.0	126.0	112.0	M12	43.0	115CWC1RA	180/60HST	5.058	
130	M130	15.0	115.0	114.0	123.3	3.15	3.15	146.1	146.1	180.0	126.0	112.0	M12	43.0	130CWC1RA	180/60HST	6.158	

All dimensions in millimetres

Note: *LSF Shrouds also available on request. †Alternative armour clamping range available for non-standard armour sizes. Marine approvals including Lloyds, DNV & ABS are also available from CMP Products.

E1W CIEL CABLE GLAND

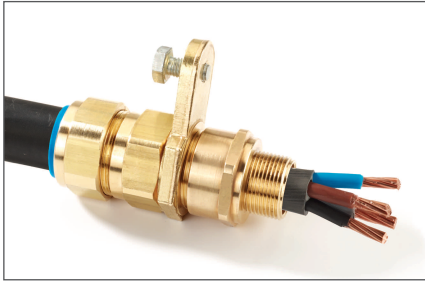

E1W-CIEL Industrial Cable Gland

Cable gland for use with all types of SWA cable providing an IP66 environmental seal onto the cable inner bedding and outer cable sheath. The cable gland being suitable for armoured cables, provides mechanical retention and electrical continuity via armour wire termination. The comes complete with CMP unique Cast Integral Earth Lug (CIEL) concept. This is particular suitable for H.V. systems where a high level of protection against fault currents is required.

TECHNICAL DATA	
Type	E1W CIEL
Design Specification	BS 6121:Part 1:1989, EN 50262:1999
EN 50262 Mechanical Classifications	Retention = Class B, Impact = Level 8,
EN 50262 Electrical Classifications	Category C
GOST R Certificate Number	POCC GB. ГБ05.H00110
GOST K Certificate Number	KZ7500052.05.01.00063
RoK Permit for Use Number	08-067693
Continuous Operating Temperature	-60°C to +150°C
Ingress Protection Rating	IP66
Standard Gland Material	Brass
Alternative Gland Material	Electroless Nickel Plated Brass, Aluminium
Seal Material	CMP Formulated Thermoplastic Elastomer
Cable Type	Single Wire Armour (SWA), Aluminium Wire Armour (AWA)
Armour Clamping	Detachable Armour Cone & AnyWay Universal Clamping Ring
Sealing Technique	CMP Inner Displacement Seal & Unique CMP "LRS"™ Outer Seal (Load Retention Seal)
Sealing Area(s)	Cable Inner Bedding & Cable Outer Sheath
Optional Accessories	Adaptor/Reducer, Entry Thread Seal, Locknut, Serrated Washer, Shroud

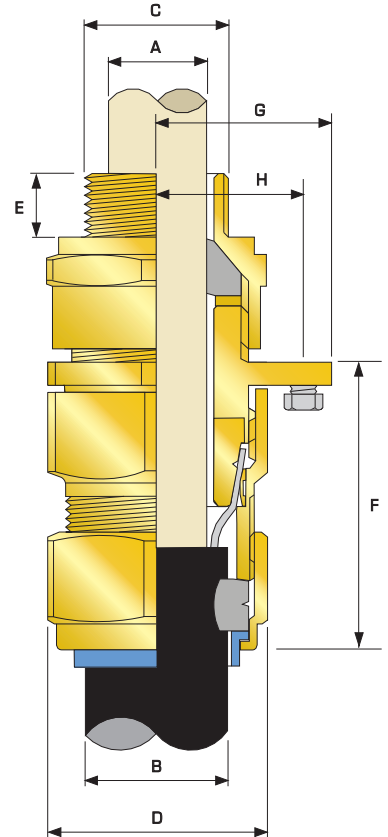

Cable Gland Selection Table

Cable Gland Size	Available Entry Threads 'C'			Minimum Thread Length 'E'	Cable Bedding Diameter 'A'		Overall Cable Diameter 'B'		Armour Range †		Nominal Across Flats 'D'	Nominal Across Corners 'D'	Nominal Protrusion Length 'F'	Nominal Radius Dimension		CIEL Earth Bolt Size	Earth Fault Current Rating (kA)	Ordering Reference (Brass Metric)	PVC Shroud Reference*	Cable Gland Weight (Kgs)
	Standard	Option			Min	Max	Min	Max	Min	Max				'H'	'G'					
		Metric	NPT																	
20S	M20	1/2"	3/4"	10.0	6.1	11.7	9.5	15.9	0.9	1.25	24.0	26.6	58.5	28.6	38.6	M8	26.0	20SE1WC1RA	PVC04	0.142
20	M20	1/2"	3/4"	10.0	6.5	14.0	12.5	20.9	0.9	1.25	30.5	33.3	60.5	31.8	41.8	M8	26.0	20E1WC1RA	PVC06	0.230
25S	M25	3/4"	1"	10.0	11.1	20.0	14.0	22.0	1.25	1.6	37.5	40.5	67.5	31.8	50.8	M8	26.0	25SE1WC1RA	PVC09	0.328
25	M25	3/4"	1"	10.0	11.1	20.0	18.2	26.2	1.25	1.6	37.5	40.5	67.5	38.1	50.8	M8	26.0	25E1WC1RA	PVC09	0.328
32	M32	1"	1-1/4"	15.0	17.0	26.3	23.7	33.9	1.6	2.0	46.0	51.0	69.5	41.3	54.0	M10	26.0	32E1WC1RA	PVC11	0.470
40	M40	1-1/4"	1-1/2"	15.0	22.0	32.2	27.9	40.4	1.6	2.0	55.0	61.0	78.0	50.8	69.0	M12	26.0	40E1WC1RA	PVC15	0.780
50S	M50	1-1/2"	2"	15.0	29.5	38.2	35.2	46.7	2.0	2.5	60.0	66.5	75.5	57.2	75.0	M12	43.0	50SE1WC1RA	PVC18	0.960
50	M50	2"	2-1/2"	15.0	35.6	44.1	40.4	53.1	2.0	2.5	70.0	78.6	80.5	60.3	80.0	M12	43.0	50E1WC1RA	PVC21	1.150
63S	M63	2"	2-1/2"	15.0	40.1	50.0	45.6	59.4	2.0	2.5	75.0	83.2	91.5	70.0	90.0	M12	43.0	63SE1WC1RA	PVC23	1.700
63	M63	2-1/2"	3"	15.0	47.2	56.0	54.6	65.9	2.0	2.5	80.0	89.0	92.0	69.9	90.0	M12	43.0	63E1WC1RA	PVC25	1.650
75S	M75	2-1/2"	3"	15.0	52.8	62.0	59.0	72.1	2.0	2.5	89.0	101.6	99.0	76.2	97.0	M12	43.0	75SE1WC1RA	PVC28	2.600
75	M75	3"	3-1/2"	15.0	59.1	68.0	66.7	78.5	2.0	2.5	99.0	111.1	102.0	88.9	108.0	M12	43.0	75E1WC1RA	PVC30	3.300
90	M90	3"	3-1/2"	15.0	66.6	80.0	76.2	90.4	3.15	3.15	114.0	128.6	120.0	95.3	112.0	M12	43.0	90E1WC1RA	PVC32	4.850
100	M100	4"	-	15.0	76.0	91.0	89.1	101.5	3.15	4.0	123.0	123.0	138.0	95.3	112.0	M12	43.0	100E1WC1RA	150/50HST	5.950
115	M115	-	-	15.0	86.0	98.0	101.3	110.3	3.15	4.0	133.4	133.4	147.6	95.3	112.0	M12	43.0	115E1WC1RA	180/60HST	6.050
130	M130	-	-	15.0	97.0	115.0	114.0	123.3	3.15	4.0	146.1	146.1	161.9	95.3	112.0	M12	43.0	130E1WC1RA	180/60HST	7.150

All dimensions in millimetres

Note: *LSF Shrouds also available on request. †Alternative armour clamping range available for non-standard armour sizes. Marine approvals including Lloyds, DNV & ABS are also available from CMP Products.

E2W CIEL CABLE GLAND

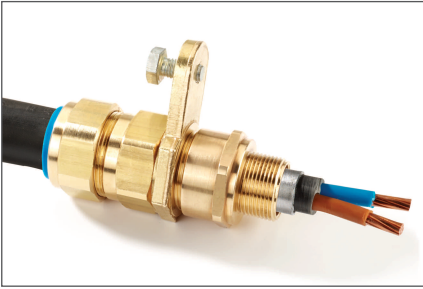

E2W-CIEL Industrial Cable Gland

Cable gland for use with all types of SWA and lead sheath cables providing an IP66 environmental seal onto the cable lead sheath and cable outer sheath. The cable gland being suitable for armoured cables, provides mechanical retention and electrical continuity between the gland, lead sheath and armour wire termination. The gland comes complete with CMP unique Cast Integral Earth Lug (CIEL) concept. This is particular suitable for H.V. systems where a high level of protection against fault currents is required.

TECHNICAL DATA	
Type	E2W CIEL
Design Specification	BS 6121:Part 1:1989, EN 50262
EN 50262 Mechanical Classifications	Retention = Class B, Impact = Level 8,
EN 50262 Electrical Classifications	Category C
GOST R Certificate Number	POCC GB. ГБ05.H00110
GOST K Certificate Number	KZ7500052.05.01.00063
RoK Permit for Use Number	08-067693
Continuous Operating Temperature	-60°C to +150°C
Ingress Protection Rating	IP66
Standard Gland Material	Brass
Alternative Gland Material	Electroless Nickel Plated Brass, Aluminium
Seal Material	CMP Formulated Thermoplastic Elastomer
Cable Type	Lead Sheathed Single Wire Armour (SWA), Lead Sheathed Aluminium Wire Armour (AWA)
Armour Clamping	Detachable Armour Cone & AnyWay Universal Clamping Ring
Sealing Technique	CMP Inner Displacement Seal & Unique CMP "LRS"™ Outer Seal (Load Retention Seal)
Sealing Area(s)	Cable Inner Bedding & Cable Outer Sheath
Optional Accessories	Adaptor/Reducer, Entry Thread Seal, Locknut, Serrated Washer, Shroud

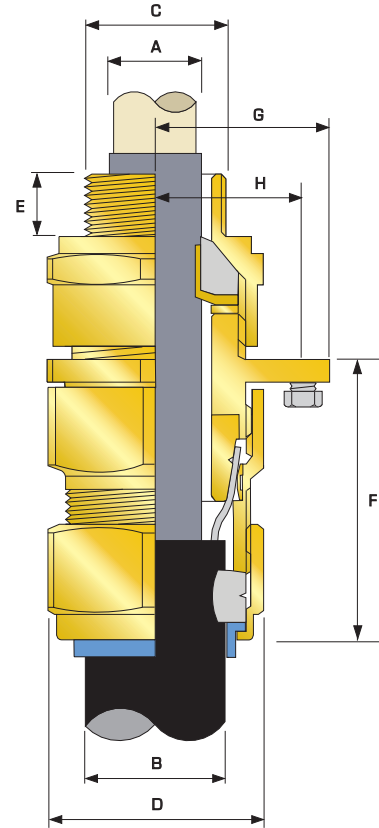

Cable Gland Selection Table

Cable Gland Size	Available Entry Threads 'C'			Minimum Thread Length 'E'	Cable Bedding Diameter 'A'		Overall Cable Diameter 'B'		Armour Range †		Nominal Across Flats 'D'	Nominal Across Corners 'D'	Nominal Protrusion Length 'F'	Nominal Radius Dimension		CIEL Earth Bolt Size	Earth Fault Current Rating (kA)	Ordering Reference (Brass Metric)	PVC Shroud Reference*	Cable Gland Weight (Kgs)
	Standard	Option			Min	Max	Min	Max	Min	Max	Max	Max		'H'	'G'					
		Metric	NPT																	
20S	M20	1/2"	3/4"	10.0	6.1	11.7	9.5	15.9	0.9	1.25	24.0	26.6	58.5	28.6	38.6	M8	26.0	20SE2WC1RA	PVC04	0.142
20	M20	1/2"	3/4"	10.0	6.5	14.0	12.5	20.9	0.9	1.25	30.5	33.3	60.5	31.8	41.8	M8	26.0	20E2WC1RA	PVC06	0.230
25S	M25	3/4"	1"	10.0	11.1	20.0	14.0	22.0	1.25	1.6	37.5	40.5	67.5	31.8	50.8	M8	26.0	25SE2WC1RA	PVC09	0.328
25	M25	3/4"	1"	10.0	11.1	20.0	18.2	26.2	1.25	1.6	37.5	40.5	67.5	38.1	50.8	M8	26.0	25E2WC1RA	PVC09	0.328
32	M32	1"	1-1/4"	15.0	17.0	26.3	23.7	33.9	1.6	2.0	46.0	51.0	69.5	41.3	54.0	M10	26.0	32E2WC1RA	PVC11	0.470
40	M40	1-1/4"	1-1/2"	15.0	22.0	32.2	27.9	40.4	1.6	2.0	55.0	61.0	78.0	50.8	69.0	M12	26.0	40E2WC1RA	PVC15	0.780
50S	M50	1-1/2"	2"	15.0	29.5	38.2	35.2	46.7	2.0	2.5	60.0	66.5	75.5	57.2	75.0	M12	43.0	50SE2WC1RA	PVC18	0.960
50	M50	2"	2-1/2"	15.0	35.6	44.1	40.4	53.1	2.0	2.5	70.0	78.6	80.5	60.3	80.0	M12	43.0	50E2WC1RA	PVC21	1.150
63S	M63	2"	2-1/2"	15.0	40.1	50.0	45.6	59.4	2.0	2.5	75.0	83.2	91.5	70.0	90.0	M12	43.0	63SE2WC1RA	PVC23	1.700
63	M63	2-1/2"	3"	15.0	47.2	56.0	54.6	65.9	2.0	2.5	80.0	89.0	92.0	69.9	90.0	M12	43.0	63E2WC1RA	PVC25	1.650
75S	M75	2-1/2"	3"	15.0	52.8	62.0	59.0	72.1	2.0	2.5	89.0	101.6	99.0	76.2	97.0	M12	43.0	75SE2WC1RA	PVC28	2.600
75	M75	3"	3-1/2"	15.0	59.1	68.0	66.7	78.5	2.0	2.5	99.0	111.1	102.0	88.9	108.0	M12	43.0	75E2WC1RA	PVC30	3.300
90	M90	3"	3-1/2"	15.0	66.6	80.0	76.2	90.4	3.15	3.15	114.0	128.6	120.0	95.3	112.0	M12	43.0	90E2WC1RA	PVC32	4.850
100	M100	4"	-	15.0	76.0	91.0	89.1	101.5	3.15	4.0	123.0	123.0	138.0	95.3	112.0	M12	43.0	100E2WC1RA	150/50HST	5.950
115	M115	-	-	15.0	86.0	98.0	101.3	110.3	3.15	4.0	133.4	133.4	147.6	95.3	112.0	M12	43.0	115E2WC1RA	180/60HST	6.050
130	M130	-	-	15.0	97.0	115.0	114.0	123.3	3.15	4.0	146.1	146.1	161.9	95.3	112.0	M12	43.0	130E2WC1RA	180/60HST	7.150

All dimensions in millimetres

Note: *LSF Shrouds also available on request. †Alternative armour clamping range available for non-standard armour sizes. Marine approvals including Lloyds, DNV & ABS are also available from CMP Products.



CMP ZEN INSULATED PRODUCTS FOR SAFE EARTHING SYSTEMS



ZEN INSULATED CABLE GLANDS

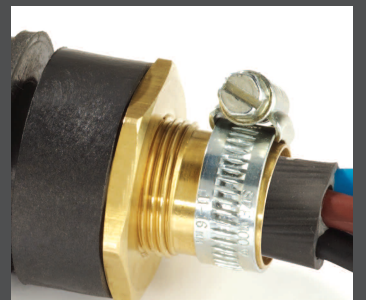
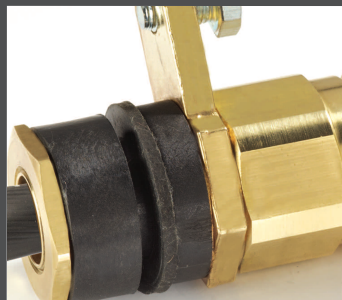



■ APPLICATION

The CMP ZEN Range of insulated cable glands enables an innovative approach for electrical cable installations by providing a cable glanding method which permits the zoning of earth connections for earthed neutral system of supply. CMP ZEN cable glands enable flexibility in design of the earthing circuit and means of testing earth circuits without disconnecting the cable gland.

Circulating currents can be eliminated and cable noise in instrument cables can be controlled by single point earthing.

Insulated components are available in materials tested for use in containment areas of Nuclear type Pressurised Water Reactor Power Stations.

■ PRODUCTS

CMP ZEN range of cable glands are available to suit cables with single wire armour, including steel and aluminium wire armour, aluminium strip armour and steel tape armour.

■ SPECIFICATIONS & APPROVALS

Designed generally in accordance with BS6121 and EN50262

Specified extensively in the UK Power Stations and tested to GDCD190 specification.

■ HOW TO ORDER

Please state cable gland type and size e.g. 25B3241RA.

Refer to specific catalogue page.

B324 ZEN CABLE GLAND

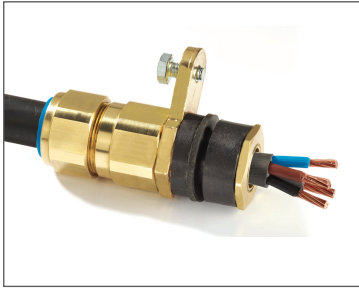

B348 ZEN CABLE GLAND

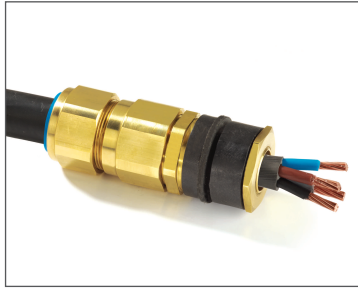

B324 & B348 ZEN Insulated Cable Gland

Cable gland for use with all types of SWA cable providing an IP66 environmental seal onto the cable outer sheath. The cable gland being suitable for armoured cables, provides mechanical retention and electrical continuity via armour wire termination. The type B324 comes complete with CMP unique Cast Integral Earth Lug (CIEL) concept. This is particularly suitable for H.V. systems where a high level of protection against fault currents is required. This glanding concept effectively insulates the gland and cable armour from the equipment and eliminates system circulating currents. It is usual to install the type B324 at the supply end of the cable and the type B348 at the load end.

TECHNICAL DATA	
Type	B324 / B348
Design Specification	BS 6121:Part 1:1989, GDCD 190, EN 50262:1999
EN 50262 Mechanical Classifications	Retention = Class B, Impact = Level 8,
EN 50262 Electrical Classifications	Category A without use of an Earth Tag, Category B with an Earth Tag & Category C with CIEL.
GOST R Certificate Number	POCC GB. ГБ05.H00110
GOST K Certificate Number	KZ7500052.05.01.00063
RoK Permit for Use Number	08-067693
Continuous Operating Temperature	-60°C to +150°C
Ingress Protection Rating	IP66
Standard Gland Material	Brass
Alternative Gland Material	Electroless Nickel Plated Brass, Aluminium
Seal Material	CMP Formulated Thermoplastic Elastomer
Cable Type	Single Wire Armour (SWA), Aluminium Wire Armour (AWA)
Armour Clamping	Detachable Armour Cone & AnyWay Universal Clamping Ring
Sealing Technique	Unique CMP "LRS"™ Outer Seal (Load Retention Seal)
Sealing Area(s)	Cable Outer Sheath
Optional Accessories	Shroud, Earth Tag (B324 & A348 only)

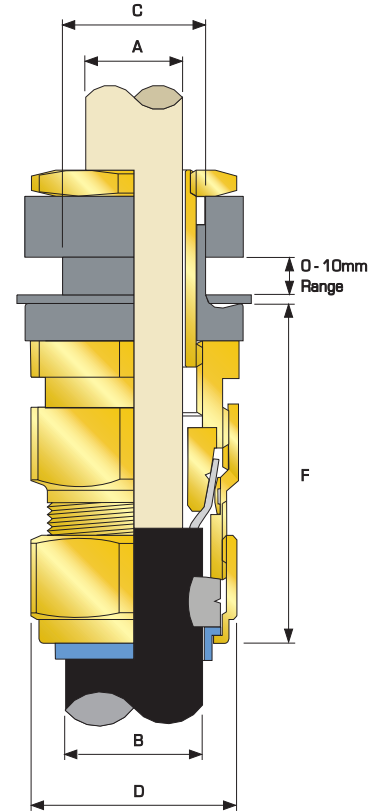

Type B348 Illustrated

Aluminium version available for AWA cables. When ordering Please substitute letter B in B324 & B348 with letter A.

Please refer to catalogue page 102 for dimensional details of the CIEL feature included in the B324 and A324 designs

Cable Gland Selection Table

Cable Gland Size	Clearance Hole Diameter 'C'	Cable Bedding Diameter 'A'		Overall Cable Diameter 'B'		Armour Range †		Nominal Across Flats 'D'	Nominal Across Corners 'D'	Nominal Protrusion Length 'F'	Ordering Reference Brass With CIEL LUG (B324)	Ordering Reference Brass Without CIEL LUG (B348)	PVC Shroud Reference*	B324 Cable Gland Weight (Kgs)
		Max	Min	Max	Min	Max	Max							
20S	20.5	11.7	9.5	15.9	0.9	1.25	24.0	26.6	58.0	20SB3241RA	20SB3481RA	PVC04	0.187	
20	20.5	14.0	12.5	20.9	0.9	1.25	30.5	33.3	65.0	20B3241RA	20B3481RA	PVC06	0.235	
25S	25.5	20.0	14.0	22.0	1.25	1.6	37.5	40.5	70.0	25SB3241RA	25SB3481RA	PVC09	0.334	
25	25.5	20.0	18.2	26.2	1.25	1.6	37.5	40.5	70.0	25B3241RA	25B3481RA	PVC09	0.334	
32	32.5	26.3	23.7	33.9	1.6	2.0	46.0	51.0	70.0	32B3241RA	32B3481RA	PVC11	0.458	
40	40.5	32.2	27.9	40.4	1.6	2.0	55.0	61.0	70.0	40B3241RA	40B3481RA	PVC15	0.689	
50S	50.5	38.2	35.2	46.7	2.0	2.5	60.0	66.5	72.0	50SB3241RA	50SB3481RA	PVC18	0.863	
50	50.5	44.1	40.4	53.1	2.0	2.5	70.0	78.6	86.0	50B3241RA	50B3481RA	PVC21	1.028	
63S	63.5	50.0	45.6	59.4	2.0	2.5	75.0	83.2	86.0	63SB3241RA	63SB3481RA	PVC23	1.589	
63	63.5	56.0	54.6	65.9	2.0	2.5	80.0	89.0	96.0	63B3241RA	63B3481RA	PVC25	1.587	
75S	75.5	62.0	59.0	72.1	2.0	2.5	89.0	101.6	98.0	75SB3241RA	75SB3481RA	PVC28	2.229	
75	75.5	68.0	66.7	78.5	2.0	2.5	99.0	111.1	111.0	75B3241RA	75B3481RA	PVC30	2.534	
90	90.5	79.4	76.2	90.4	3.15	3.15	114.0	128.6	136.0	90B3241RA	90B3481RA	PVC32	4.204	

All dimensions in millimetres

Note: *LSF Shrouds also available on request. †Alternative armour clamping range available for non-standard armour sizes. Marine approvals including Lloyds, DNV & ABS are also available from CMP Products.

B367 ZEN CABLE GLAND

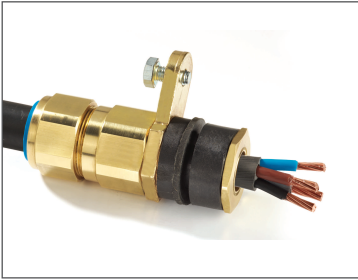

B368 ZEN CABLE GLAND

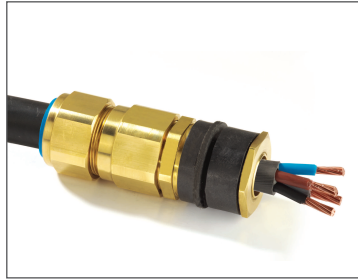

B367 & B368 ZEN Insulated Cable Gland

Cable gland for use with all types of DSTA cable providing an IP66 environmental seal onto the cable outer sheath. The cable gland being suitable for armoured cables, provides mechanical retention and electrical continuity via armour wire termination. The type B367 comes complete with CMP unique Cast Integral Earth Lug (CIEL) concept. This is particular suitable for H.V. systems where a high level of protection against fault currents is required. This glanding concept effectively insulates the gland and cable armour from the equipment and eliminates system circulating currents. It is usual to install the type B367 at the supply end of the cable and the type B368 at the load end.

TECHNICAL DATA	
Type	B367 / B368
Design Specification	BS 6121:Part 1:1989, GDCD 190, EN 50262:1999
EN 50262 Mechanical Classifications	Retention = Class B, Impact = Level 8,
EN 50262 Electrical Classifications	Category A without use of an Earth Tag, Category B with an Earth Tag & Category C with CIEL.
GOST R Certificate Number	POCC GB. ГБ05.H00110
GOST K Certificate Number	KZ7500052.05.01.00063
RoK Permit for Use Number	08-067693
Continuous Operating Temperature	-60°C to +150°C
Ingress Protection Rating	IP66
Standard Gland Material	Brass
Alternative Gland Material	Electroless Nickel Plated Brass, Aluminium
Seal Material	CMP Formulated Thermoplastic Elastomer
Cable Type	Wire Braid Armour, Strip Armour (e.g. ASA), Pliable Wire Armour (PWA), Steel Tape Armour (STA).
Armour Clamping	Detachable Armour Cone & AnyWay Universal Clamping Ring
Sealing Technique	Unique CMP "LRS"™ Outer Seal (Load Retention Seal)
Sealing Area(s)	Outer Sheath
Optional Accessories	Shroud, Earth Tag (B368 & A368 only)

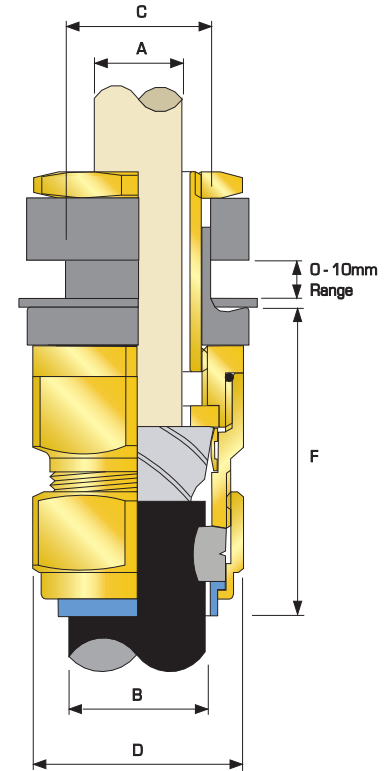

B368 Illustrated

Aluminium version available for AWA cables. When ordering Please substitute letter B in B367 & B368 with letter A.

Please refer to catalogue page 102 for dimensional details of the CIEL feature included in the B367 and A367 designs

Cable Gland Selection Table

Cable Gland Size	Clearance Hole Diameter 'C'	Cable Bedding Diameter 'A'		Overall Cable Diameter 'B'		Armour Range †		Nominal Across Flats 'D'	Nominal Across Corners 'D'	Nominal Protrusion Length 'F'	Ordering Reference Brass With CIEL LUG (B367)	Ordering Reference Brass Without CIEL LUG (B368)	PVC Shroud Reference*	B367 Cable Gland Weight (Kgs)
		Max	Min	Max	Min	Max	Max							
20S	20.5	11.7	9.50	15.9	0.0	1.0	24.0	26.6	58.0	20SB3671RA	20SB3681RA	PVC04	0.187	
20	20.5	14.0	12.5	20.9	0.0	1.0	30.5	33.3	65.0	20B3671RA	20B3681RA	PVC06	0.235	
25S	25.5	20.0	14.0	22.0	0.0	1.0	37.5	40.5	70.0	25SB3671RA	25SB3681RA	PVC09	0.334	
25	25.5	20.0	18.2	26.2	0.0	1.0	37.5	40.5	70.0	25B3671RA	25B3681RA	PVC09	0.334	
32	32.5	26.3	23.7	33.9	0.0	1.0	46.0	51.0	70.0	32B3671RA	32B3681RA	PVC11	0.458	
40	40.5	32.2	27.9	40.4	0.0	1.0	55.0	61.0	70.0	40B3671RA	40B3681RA	PVC15	0.689	
50S	50.5	38.2	35.2	46.7	0.0	1.0	60.0	66.5	72.0	50SB3671RA	50SB3681RA	PVC18	0.863	
50	50.5	44.1	40.4	53.1	0.0	1.0	70.0	78.6	86.0	50B3671RA	50B3681RA	PVC21	1.028	
63S	63.5	50.0	45.6	59.4	0.0	1.0	75.0	83.2	86.0	63SB3671RA	63SB3681RA	PVC23	1.589	
63	63.5	56.0	54.6	65.9	0.0	1.0	80.0	89.0	98.0	63B3671RA	63B3681RA	PVC25	1.587	
75S	75.5	62.0	59.0	72.1	0.0	1.0	89.0	101.6	98.0	75SB3671RA	75SB3681RA	PVC28	2.229	
75	75.5	68.0	66.7	78.5	0.0	1.0	99.0	111.1	111.0	75B3671RA	75B3681RA	PVC30	2.534	
90	90.5	80.0	76.2	90.4	0.0	1.6	114.0	128.6	136.0	90B3671RA	90B3681RA	PVC32	4.204	

All dimensions in millimetres

Note: *LSF Shrouds also available on request. †Alternative armour clamping range available for non-standard armour sizes. Marine approvals including Lloyds, DNV & ABS are also available from CMP Products.

B327 ZEN CABLE GLAND

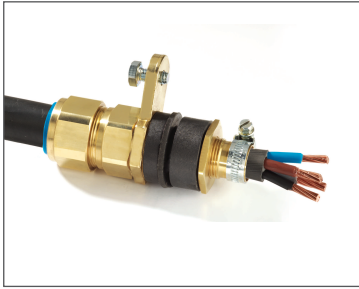

B350 ZEN CABLE GLAND

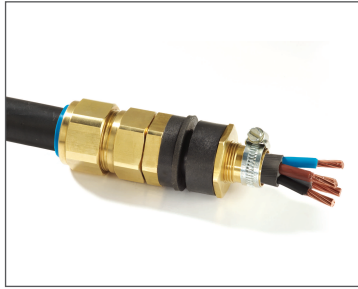

B327 & B350 ZEN Insulated Cable Gland

Cable gland for use with all types of cable providing an IP66 environmental seal onto the cable outer sheath. The cable gland being suitable for armoured cables, provides mechanical retention and electrical continuity via armour wire termination. The type B327 comes complete with CMP unique Cast Integral Earth Lug (CIEL) concept. This is particular suitable for H.V. systems where a high level of protection against fault currents is required. This glanding concept effectively insulates the gland and cable armour from the equipment and eliminates system circulating currents. It is usual to install the type B327 at the supply end of the cable and the type B350 at the load end. This gland differs from the B324 type in that this gland also provides termination facilities for the cable copper tape screening.

TECHNICAL DATA

Type	B327 / B350
Design Specification	BS 6121:Part 1:1989, GDCD 190, EN 50262:1999
EN 50262 Mechanical Classifications	Retention = Class B, Impact = Level 8,
EN 50262 Electrical Classifications	Category A without use of an Earth Tag, Category B with an Earth Tag & Category C with CIEL.
GOST R Certificate Number	POCC GB. ГБ05.H00110
GOST K Certificate Number	KZ7500052.05.01.00063
RoK Permit for Use Number	08-067693
Continuous Operating Temperature	-60°C to +150°C
Ingress Protection Rating	IP66
Standard Gland Material	Brass
Alternative Gland Material	Electroless Nickel Plated Brass, Aluminium
Seal Material	CMP Formulated Thermoplastic Elastomer
Cable Type	Single Wire Armour (SWA), Aluminium Wire Armour (AWA)
Armour Clamping	Detachable Armour Cone & AnyWay Universal Clamping Ring
Sealing Technique	Unique CMP "LRS"™ Outer Seal (Load Retention Seal)
Sealing Area(s)	Cable Outer Sheath
Optional Accessories	Shroud, Earth Tag (B350 & A350 only)

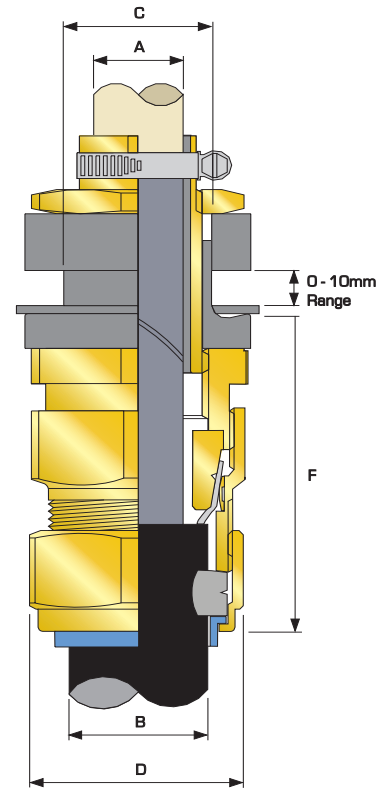

B350 Illustrated

Aluminium version available for AWA cables. When ordering Please substitute letter B in B327 & B350 with letter A.

Please refer to catalogue page 102 for dimensional details of the CIEL feature included in the B327 and A327 designs

Cable Gland Selection Table

Cable Gland Size	Clearance Hole Diameter 'C'	Cable Bedding Diameter 'A'		Overall Cable Diameter 'B'		Armour Range †		Nominal Across Flats 'D'	Nominal Across Corners 'D'	Nominal Protrusion Length 'F'	Ordering Reference Brass With CIEL LUG (B327)	Ordering Reference Brass Without CIEL LUG (B350)	PVC Shroud Reference*	B327 Cable Gland Weight (Kgs)
		Max	Min	Max	Min	Max	Max							
20S	20.5	11.7	9.5	15.9	0.9	1.25	24.0	26.6	58.0	20SB3271RA	20SB3501RA	PVC03	0.187	
20	20.5	14.0	12.5	20.9	0.9	1.25	30.5	33.3	65.0	20B3271RA	20B3501RA	PVC06	0.235	
25S	25.5	20.0	14.0	22.0	1.25	1.6	37.5	40.5	70.0	25SB3271RA	25SB3501RA	PVC09	0.334	
25	25.5	20.0	18.2	26.2	1.25	1.6	37.5	40.5	70.0	25B3271RA	25B3501RA	PVC09	0.334	
32	32.5	26.3	23.7	33.9	1.6	2.0	46.0	51.0	70.0	32B3271RA	32B3501RA	PVC11	0.458	
40	40.5	32.2	27.9	40.4	1.6	2.0	55.0	61.0	70.0	40B3271RA	40B3501RA	PVC15	0.689	
50S	50.5	38.2	35.2	46.7	2.0	2.5	60.0	66.5	72.0	50SB3271RA	50SB3501RA	PVC18	0.863	
50	50.5	44.1	40.4	53.1	2.0	2.5	70.0	78.6	86.0	50B3271RA	50B3501RA	PVC21	1.028	
63S	63.5	50.0	45.6	59.4	2.0	2.5	75.0	83.2	86.0	63SB3271RA	63SB3501RA	PVC23	1.589	
63	63.5	56.0	54.6	65.9	2.0	2.5	80.0	89.0	96.0	63B3271RA	63B3501RA	PVC25	1.587	
75S	75.5	62.0	59.0	72.1	2.0	2.5	89.0	101.6	98.0	75SB3271RA	75SB3501RA	PVC28	2.229	
75	75.5	68.0	66.7	78.5	2.0	2.5	99.0	111.1	111.0	75B3271RA	75B3501RA	PVC30	2.534	
90	90.5	80.0	76.2	90.4	3.15	3.15	114.0	128.6	136.0	90B3271RA	90B3501RA	PVC32	4.204	

All dimensions in millimetres

Note: *LSF Shrouds also available on request. †Alternative armour clamping range available for non-standard armour sizes. Marine approvals including Lloyds, DNV & ABS are also available from CMP Products.

B323 ZEN CABLE GLAND

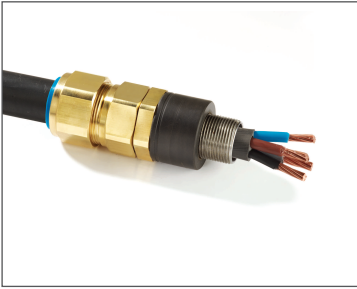

B347 ZEN CABLE GLAND

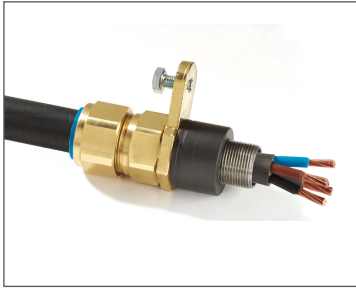

B323 & B347 ZEN Insulated Cable Gland

Cable gland for use with all types of SWA cable providing an IP66 environmental seal onto the cable outer sheath. The cable gland being suitable for armoured cables, provides mechanical retention and electrical continuity via armour termination. The type B323 comes complete with CMP unique Cast Integral Earth Lug (CIEL) concept. This is particular suitable for H.V. systems where a high level of protection against fault currents is required. This glanding concept effectively insulates the gland and cable armour from the equipment and eliminates system circulating currents. It is usual to install the type B323 at the supply end of the cable and the type B347 at the load end. This type of insulated gland is designed for use with threaded enclosures rather than clearance or through holes.

TECHNICAL DATA	
Type	B323 / B347
Design Specification	BS 6121:Part 1:1989, GDCD 190, EN 50262:1999
EN 50262 Mechanical Classifications	Retention = Class B, Impact = Level 8,
EN 50262 Electrical Classifications	Category A without use of an Earth Tag, Category B with an Earth Tag & Category C with CIEL.
GOST R Certificate Number	POCC GB. ГБ05.H00097
GOST K Certificate Number	KZ7500052.05.01.00063
RoK Permit for Use Number	08-067693
Continuous Operating Temperature	-60°C to +150°C
Ingress Protection Rating	IP66
Standard Gland Material	Brass
Alternative Gland Material	Electroless Nickel Plated Brass, Aluminium
Seal Material	CMP Formulated Thermoplastic Elastomer
Cable Type	Single Wire Armour (SWA), Aluminium Wire Armour (AWA)
Armour Clamping	Detachable Armour Cone & AnyWay Universal Clamping Ring
Sealing Technique	Unique CMP "LRS"™ Outer Seal (Load Retention Seal)
Sealing Area(s)	Cable Outer Sheath
Optional Accessories	Shroud, Earth Tag (B323 & A323 only)

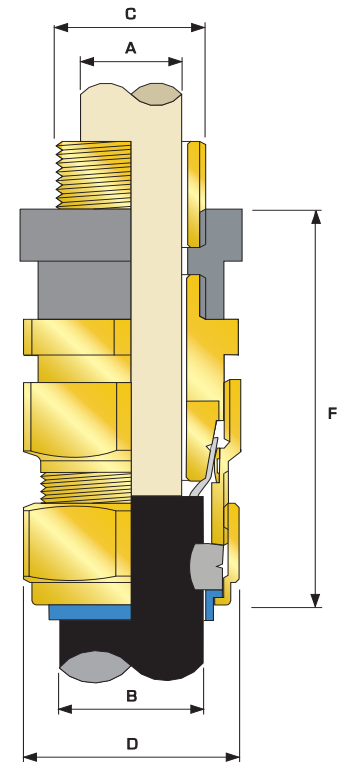

B323 Illustrated

Aluminium version available for AWA cables. When ordering Please substitute letter B in B323 & B347 with letter A.

Please refer to catalogue page 102 for dimensional details of the CIEL feature included in the B323 and A323 designs

Cable Gland Selection Table

Cable Gland Size	Entry Thread 'C'	Cable Bedding Diameter 'A'		Overall Cable Diameter 'B'		Armour Range †		Nominal Across Flats 'D'	Nominal Across Corners 'D'	Nominal Protrusion Length 'F'	Ordering Reference Brass Without CIEL LUG (B323)	Ordering Reference Brass With CIEL LUG (B347)	PVC Shroud Reference*	B323 Cable Gland Weight (Kgs)
		Max	Min	Max	Min	Max	Max	Max						
20S	M20	11.6	9.5	15.9	0.9	1.25	24.0	26.6	73.0	20SB3231RA	20SB3471RA	PVC04	0.153	
20	M20	13.9	12.5	20.9	0.9	1.25	30.5	33.3	80.0	20B3231RA	20B3471RA	PVC06	0.219	
25S	M25	19.9	14.0	22.0	1.25	1.6	37.5	40.5	85.0	25SB3231RA	25SB3471RA	PVC09	0.295	
25	M25	19.9	18.2	26.2	1.25	1.6	37.5	40.5	85.0	25B3231RA	25B3471RA	PVC09	0.295	

All dimensions in millimetres

Note: *LSF Shrouds also available on request. †Alternative armour clamping range available for non-standard armour sizes. Marine approvals including Lloyds, DNV & ABS are also available from CMP Products.



IEC Ex & ATEX HAZARDOUS AREA CABLE GLANDS

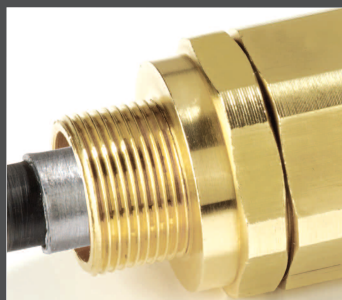

■ APPLICATION

The CMP range of IEC Ex & ATEX certified hazardous area cable glands offers solutions which are highly cost effective in their design and installation process. The CMP philosophy of delivering client and end user specific requirements can be seen from a number of significant developments in this range. Given the level of experience gained in this field CMP is able to provide a high degree of technical support and advice on the selection and use of cable glands in hazardous area applications.

■ TESTING

CMP Products offers hazardous area cable glands that are tested and certified to the latest international technical standards and through its programme of continuous product development always strives to maintain its certification in line with the very latest technical knowledge or state of the art, bringing global products to a world that can expect only the best from CMP in terms of compliance with up to date specifications and standards.

■ PRODUCTS

Triple Certified cable gland options for all types of cable with Ex d IIC, Ex e II and Ex nR II forms of protection,

■ SPECIFICATIONS & APPROVALS

Derived from the BS6121 standard which was the original 'flameproof' standard for cable glands

CMP hazardous area cable glands comply with a number of international standards including the European Normatives (EN 60079 series), IEC (IEC 60079 series) UL & CSA (UL 514B, UL 2225).

Multiple certification including ATEX, IEC Ex, GOST R, GOST K, CSA, UL, and INMETRO enables the possibility of selecting fewer standard products for more global situations. Some solutions in the standard CMP hazardous area range offer Bi-code approvals allowing their deployment under both IEC & NEC installation codes of practice.





T3CDS GLAND

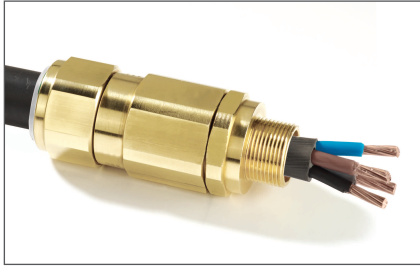

Triton CDS (T3CDS) Flameproof Ex d, Increased Safety Ex e and Restricted Breathing Ex nR Cable Gland

CMP Triton CDS Type T3CDS Triple Certified Flameproof (Type 'd'), Increased Safety (Type 'e') and Restricted Breathing (Type 'nR') indoor and outdoor cable gland for use in Zone 1, Zone 2, Zone 21 and Zone 22 Hazardous Areas with all types of armoured cable providing a Flameproof seal on the cable inner bedding and an environmental seal on the cable outer sheath. This product utilises a unique Compensating Displacement Seal (CDS) system which provides full compatibility with Restricted Breathing equipment. The cable gland provides mechanical cable retention and electrical continuity via armour wire termination. A reversible armour cone and AnyWay universal clamping ring arrangement allows the cable to be easily disconnected from the equipment, for maintenance and change out etc., and re-connected with the same consummate ease. This feature also facilitates remote make off procedures when the termination is to be conducted in confined spaces or in areas of restricted access. Separate tightening actions for the inner Compensating Displacement Seal (CDS) system and the armour termination affords maximum control over the pressure applied to the cable inner bedding. The CMP Triton CDS Cable Gland is suitable for use with all forms of equipment protection permitted in Zone 1, Zone 2, Zone 21 & Zone 22 provided always that the prevailing code of practice for selection and installation is observed, e.g. IEC 60079-14.

TECHNICAL DATA	
Type	T3CDS
Design Specification	BS 6121:Part 1:1989, EN 50262:1999, UL 514B
ATEX Certification	SIRA06ATEX1283X
Code of Protection Category	ATEX (Ex) II 2/3 GD Ex d IIC, Ex e II, Ex nR II, Ex tD A21 IP66, Equipment Zone 1, Zone 2, Zone 21, & Zone 22 - Gas Groups IIA, IIB, IIC
Compliance Standards	EN 60079-0:2006, EN 60079-1:2004, EN 60079-7:2003, EN 60079-15:2005, EN 61241-0:2004, EN 61241-1:2004
IECEx Approval Number	IECEx SIR 07.005X
Code of Protection Category	Ex d IIC / Ex e II / Ex nR II / Ex tD A21 IP66
Compliance Standards	IEC 60079-0:2004, IEC 60079-1:2003, IEC 60079-7:2006, IEC 60079-15:2005, IEC 61241-0:2004, IEC 61241-1:2004
CSA Certification	1310517
Code of Protection Category	Ex d IIC Ex e II, Class I, II, III, Class II Div 2 Groups EFG, Enclosure Type 3, 4 and 4X, Class I Div 2 Groups ABCD, Class III
Compliance Standards	CSA C22.2 No. 174-M1984, CSA C22.2 No. 25-1966, CAN/CSA-C22.2 No. 18-92, CAN/CSA-C22.2 No. 94-M91, CAN/CSA-E60079-0-2001, IEC 60079-0 1998, CAN/CSA-E79-7-95
UL Listing File Number	UBWE.E200163, CYMJ.E256366, FDJR.E256367
Code of Protection Category	Ordinary & Wet Locations, Class I, Zone 1, AEx e II, Class I, Zone 2, AEx e II
Compliance Standards	UL 514B, ANSI / UL 60079-0, ANSI / UL 60079-7
GOST R Certificate Number	POCC GB. ГБ05.Б01912
Code of Protection Category	Ex d IIC U / Ex e II U
Compliance Standards	ГОСТ P 52350.0-2005, ГОСТ P 52350.1-2005, ГОСТ P 52350.7-2005
GGTN Permit Number	PPC 00-18262
GOST K Certificate Number	KZ7500052.05.01.00063
RoK Permit for Use Number	08-067693
Lloyds Approval Number	01/00172
DNV Approval Number	E-6157
ABS Approval Number	01-LD 234401-PDA
Continuous Operating Temperature	-60°C to +130°C
Ingress Protection Rating	IP66, IP67, IP68
Deluge Protection Compliance	DTS01 : 91
Deluge Protection Document	ITS 01005029 - D
Cable Gland Material	Brass, Electroless Nickel Plated Brass, Aluminium, Stainless Steel
Seal Material	CMP SOLO LSF Thermoplastic Elastomer
Cable Type	Single Wire Armour (SWA), Aluminium Wire Armour (AWA), Pliable Wire Armour (PWA), Steel Tape Armour (STA), Wire Braid Armour, Aluminium Strip Armour (ASA), Screened Flexible Wire Braid (e.g. CY / SY), Armored & Jacketed
Armour Clamping	Reversible Armour Cone & AnyWay Universal Clamping Ring
Sealing Technique	CMP Inner CDS System & Unique CMP "LRS"™ Outer Seal (Load Retention Seal)
Sealing Area(s)	Cable Inner Bedding & Cable Outer Sheath
Optional Accessories	Locknut, Shroud, Entry Thread Seal, Serrated Washer, Earth Tag, Adaptor/Reducer

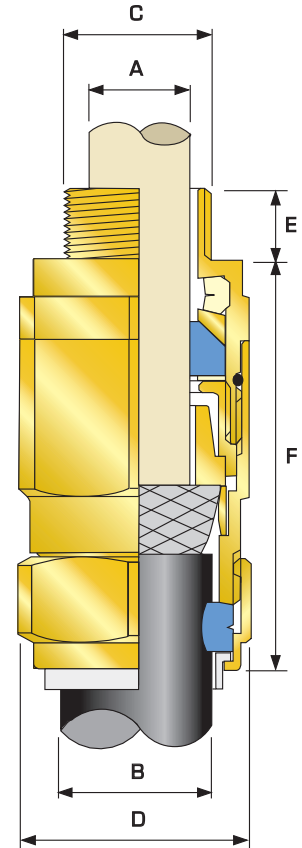

Note: Versions with dedicated armour cones, Type T3CDSW – for SWA cables only, and Type T3CDSX for all other approved cable types also available.

Note: Stepped Cone is suitable for SWA cables. Grooved Cone is suitable for all other approved armoured cables

Cable Gland Selection Table

Cable Gland Size	Available Entry Threads 'C'			Minimum Thread Length 'E'	Cable Bedding Diameter 'A'		Overall Cable Diameter 'B'		Armour Range †				Across Flats 'D'	Across Corners 'D'	Nominal Protrusion Length 'F'	Ordering Reference (Brass Metric) #	Cable Gland Weight (Kgs)
	Standard		Option		Min	Max	Min	Max	Grooved Cone		Stepped Cone						
	Metric	NPT	NPT						Min	Max	Min	Max					
20S/16	M20	1/2"	3/4"	15.0	3.1	8.7	6.1	11.5	0.15	1.0	0.9	1.0	24.0	26.6	70.0	20S16T3CDS1RA	0.170
20S	M20	1/2"	3/4"	15.0	6.1	11.7	9.5	15.9	0.15	1.0	0.9	1.25	24.0	26.6	70.0	20S16T3CDS1RA	0.170
20	M20	1/2"	3/4"	15.0	6.5	14.0	12.5	20.9	0.15	1.0	0.9	1.25	30.5	33.3	72.0	20T3CDS1RA	0.256
25S	M25	3/4"	1"	15.0	11.1	20.0	14.0	22.0	0.15	1.0	1.25	1.6	37.5	40.5	82.0	25S16T3CDS1RA	0.384
25	M25	3/4"	1"	15.0	11.1	20.0	18.2	26.2	0.15	1.0	1.25	1.6	37.5	40.5	82.0	25T3CDS1RA	0.379
32	M32	1"	1-1/4"	15.0	17.0	26.3	23.7	33.9	0.15	1.0	1.6	2.0	46.0	51.0	85.0	32T3CDS1RA	0.560
40	M40	1-1/4"	1-1/2"	15.0	22.0	32.2	27.9	40.4	0.15	1.0	1.6	2.0	55.0	61.0	86.0	40T3CDS1RA	0.848
50S	M50	1-1/2"	2"	15.0	29.5	38.2	35.2	46.7	0.15	1.0	2.0	2.5	60.0	66.5	98.0	50S16T3CDS1RA	1.055
50	M50	2"	2-1/2"	15.0	35.6	44.1	40.4	53.1	0.15	1.0	2.0	2.5	70.0	78.6	100.0	50T3CDS1RA	1.521
63S	M63	2"	2-1/2"	15.0	40.1	50.0	45.6	59.4	0.15	1.0	2.0	2.5	75.0	83.2	108.0	63S16T3CDS1RA	1.750
63	M63	2-1/2"	3"	15.0	47.2	56.0	54.6	65.9	0.15	1.0	2.0	2.5	80.0	89.0	103.0	63T3CDS1RA	1.685
75S	M75	2-1/2"	3"	15.0	52.8	62.0	59.0	72.1	0.15	1.0	2.0	2.5	89.0	101.6	105.0	75S16T3CDS1RA	2.345
75	M75	3"	3-1/2"	15.0	59.1	68.0	66.7	78.5	0.15	1.0	2.0	2.5	99.0	111.1	114.0	75T3CDS1RA	3.200
90	M90	3"	3-1/2"	15.0	66.6	80.0	76.2	90.4	0.25	1.6	3.15	3.15	114.0	128.6	140.0	90T3CDS1RA	5.100
100	M100	4"	4-1/2"	15.0	80.0	91.0	86.1	101.5	0.25	1.6	3.15	4.0	123.0	138.0	170.0	100T3CDS1RA	6.500
115	M115	4-1/2"	5"	15.0	90.0	98.0	101.5	110.3	0.25	1.6	3.15	4.0	133.4	147.6	210.0	115T3CDS1RA	7.000
130	M130	5"	6"	15.0	100.0	115.0	114.2	123.3	0.25	1.6	3.15	4.0	146.1	161.9	250.0	130T3CDS1RA	7.800

All dimensions in millimetres

Note: †Alternative armour clamping range available for non-standard armour sizes. Marine approvals including Lloyds, DNV & ABS are also available from CMP Products. # Other thread forms are available.

T3CDS/PB GLAND

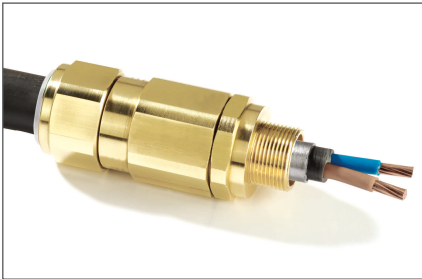

Triton CDS (T3CDSPB) Flameproof Ex d, Increased Safety Ex e and Restricted Breathing Ex nR Cable Gland

CMP Triton CDS Type T3CDS Triple Certified Flameproof (Type 'd'), Increased Safety (Type 'e') and Restricted Breathing (Type 'nR') indoor and outdoor cable gland for use in Zone 1, Zone 2, Zone 21 and Zone 22 Hazardous Areas with all types of lead sheathed / lead covered and armoured cable providing a flameproof seal on the cable inner lead sheath and an environmental seal on the cable outer sheath. This product utilises a unique Compensating Displacement Seal (CDS) system and its gas tight seal provides full compatibility with restricted breathing equipment. The cable gland being suitable for use with armoured cables, provides mechanical cable retention and electrical continuity via armour wire termination and earth bonding of the lead sheath. A reversible armour cone and AnyWay universal clamping ring arrangement allows the cable to be easily disconnected from the equipment, for maintenance and change out etc, and re-connected with the same consummate ease. This feature also facilitates remote make off procedures when the termination is to be conducted in confined spaces or in areas of restricted access. Separate tightening actions for the inner Compensating Displacement Seal (CDS) system and the armour termination affords maximum control over the pressure applied to the cable inner lead sheath. The CMP Triton CDS Cable Gland is suitable for use with all forms of equipment protection permitted in Zone 1, Zone 2, Zone 21 & Zone 22 provided always that the prevailing code of practice for selection and installation is observed, e.g. IEC 60079-14.

TECHNICAL DATA	
Type	T3CDSPB
Design Specification	BS 6121:Part 1:1989, EN 50262:1999, UL 514B
ATEX Certification	SIRA06ATEX1283X
Code of Protection Category	ATEX (Ex) II 2/3 GD Ex d IIC, Ex e II, Ex nR II - Equipment Zone 1, Zone 2, Zone 21, & Zone 22 - Gas Groups IIA, IIB, IIC
Compliance Standards	EN 60079-0:2006, EN 60079-1:2004, EN 60079-7:2003, EN 60079-15:2005, EN 61241-0:2004, EN 61241-1:2004
IECEX Approval Number	IECEX SIR 07.005X
Code of Protection Category	Ex d IIC / Ex e II / Ex nR II / Ex tD A21 IP66
Compliance Standards	IEC 60079-0:2004, IEC 60079-1:2003, IEC 60079-7:2006, IEC 60079-15:2005, IEC 61241-0:2004, IEC 61241-1:2004
CSA Certification	1310517
Code of Protection Category	Ex d IIC Ex e II, Class I, II, III, Class II Div 2 Groups EFG, Enclosure Type 3, 4 and 4X, Class I Div 2 Groups ABCD, Class III
Compliance Standards	CSA C22.2 No. 174-M1984, CSA C22.2 No. 25-1966, CAN/CSA-C22.2 No. 18-92, CAN/CSAC22.2 No. 94-M91, CAN/CSA-E60079-0-2001, IEC 60079-0 1998, CAN/CSA-E79-7-95
UL Listing File Number	UBWE.E200163, CYMJ.E256366, FDJR.E256367
Code of Protection Category	Ordinary & Wet Locations, Class I, Zone 1, AEx e II, Class I, Zone 2, AEx e II
Compliance Standards	UL 514B, ANSI / UL 60079-0, ANSI / UL 60079-7
GOST R Certificate Number	POCC GB.ГE05.B01912
Code of Protection category	Ex d IIC U / Ex e II U
Compliance Standards	ГОСТ P 52350.0-2005,ГОСТ P 52350.1-2005,ГОСТ P 52350.7-2005
GGTN Permit Number	PPC 00-18262
GOST K Certificate Number	KZ7500052.05.01.00063
RoK Permit for Use Number	08-067693
Lloyds Approval Number	01/00172
DNV Approval Number	E-6157
ABS Approval Number	01-LD 234401-PDA
Continuous Operating Temperature	-60°C to +130°C
Ingress Protection Rating	IP66, IP67, IP68
Deluge Protection Compliance	DTS01 : 91
Deluge Protection Document	ITS 01005029
Cable Gland Material	Brass, Electroless Nickel Plated Brass, Aluminium, Stainless Steel
Seal Material	CMP SOLO LSF Thermoplastic Elastomer
Cable Type	Lead Sheathed & Single Wire Armour (SWA), Aluminium Wire Armour (AWA), Pliable Wire Armour (PWA), Steel Tape Armour (STA), Wire Braid Armour, Aluminium Strip Armour (ASA).
Armour Clamping	Reversible Armour Cone & AnyWay Universal Clamping Ring
Sealing Technique	CMP Inner CDS System & Unique CMP "LRS"™ Outer Seal (Load Retention Seal)
Sealing Area(s)	Cable Inner Bedding & Cable Outer Sheath
Optional Accessories	Locknut, Shroud, Entry Thread Seal, Serrated Washer, Earth Tag, Adaptor/Reducer

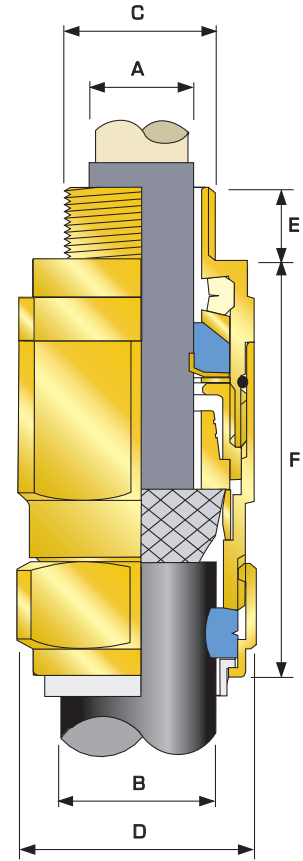

Note: Stepped Cone is suitable for SWA cables, Grooved Cone is suitable for all other approved armoured cables

Cable Gland Selection Table

Cable Gland Size	Available Entry Threads 'C'			Minimum Thread Length 'E'	Cable Bedding Diameter 'A'		Overall Cable Diameter 'B'		Armour Range †				Across Flats 'D'	Across Corners 'D'	Nominal Protrusion Length 'F'	Ordering Reference (Brass Metric) #	Cable Gland Weight (Kgs)*
	Standard		Option		Min	Max	Min	Max	Grooved Cone		Stepped Cone						
	Metric	NPT	NPT						Min	Max	Min	Max					
20S/16	M20	1/2"	3/4"	15.0	3.1	8.7	6.1	11.5	0.15	1.0	0.9	1.0	24.0	26.6	70.0	20S16T3CDSPB1RA	0.170
20S	M20	1/2"	3/4"	15.0	6.1	11.7	9.5	15.9	0.15	1.0	0.9	1.25	24.0	26.6	70.0	20S16T3CDSPB1RA	0.170
20	M20	1/2"	3/4"	15.0	6.5	14.0	12.5	20.9	0.15	1.0	0.9	1.25	30.5	33.3	72.0	20T3CDSPB1RA	0.256
25S	M25	3/4"	1"	15.0	11.1	20.0	14.0	22.0	0.15	1.0	1.25	1.6	37.5	40.5	82.0	25S16T3CDSPB1RA	0.384
25	M25	3/4"	1"	15.0	11.1	20.0	18.2	26.2	0.15	1.0	1.25	1.6	37.5	40.5	82.0	25T3CDSPB1RA	0.379
32	M32	1"	1-1/4"	15.0	17.0	26.3	23.7	33.9	0.15	1.0	1.6	2.0	46.0	51.0	85.0	32T3CDSPB1RA	0.560
40	M40	1-1/4"	1-1/2"	15.0	22.0	32.2	27.9	40.4	0.15	1.0	1.6	2.0	55.0	61.0	86.0	40T3CDSPB1RA	0.848
50S	M50	1-1/2"	2"	15.0	29.5	38.2	35.2	46.7	0.15	1.0	2.0	2.5	60.0	66.5	98.0	50S16T3CDSPB1RA	1.055
50	M50	2"	2-1/2"	15.0	35.6	44.1	40.4	53.1	0.15	1.0	2.0	2.5	70.0	78.6	100.0	50T3CDSPB1RA	1.521
63S	M63	2"	2-1/2"	15.0	40.1	50.0	45.6	59.4	0.15	1.0	2.0	2.5	75.0	83.2	108.0	63S16T3CDSPB1RA	1.750
63	M63	2-1/2"	3"	15.0	47.2	56.0	54.6	65.9	0.15	1.0	2.0	2.5	80.0	89.0	103.0	63T3CDSPB1RA	1.685
75S	M75	2-1/2"	3"	15.0	52.8	62.0	59.0	72.1	0.15	1.0	2.0	2.5	89.0	101.6	105.0	75S16T3CDSPB1RA	2.345
75	M75	3"	3-1/2"	15.0	59.1	68.0	66.7	78.5	0.15	1.0	2.0	2.5	99.0	111.1	114.0	75T3CDSPB1RA	3.200
90	M90	3"	3-1/2"	15.0	66.6	80.0	76.2	90.4	0.25	1.6	3.15	3.15	114.0	128.6	140.0	90T3CDSPB1RA	5.100
100	M100	4"	4-1/2"	15.0	80.0	91.0	86.1	101.5	0.25	1.6	3.15	4.0	123.0	138.0	170.0	100T3CDSPB1RA	6.500
115	M115	4-1/2"	5"	15.0	90.0	98.0	101.5	110.3	0.25	1.6	3.15	4.0	133.4	147.6	210.0	115T3CDSPB1RA	7.000
130	M130	5"	6"	15.0	100.0	115.0	114.2	123.3	0.25	1.6	3.15	4.0	146.1	161.9	250.0	130T3CDSPB1RA	7.800

All dimensions in millimetres

Note: †Alternative armour clamping range available for non-standard armour sizes. Marine approvals including Lloyds, DNV & ABS are also available from CMP Products. # Other thread forms are available.

A2F CABLE GLAND

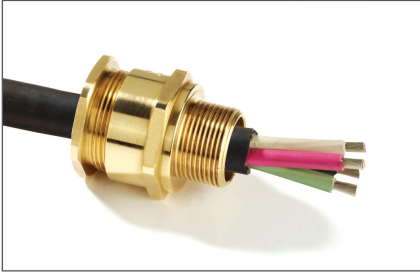

Type A2F Tri-Star Flameproof Ex d, Increased Safety Ex e and Restricted Breathing Ex nR Cable Gland

CMP Type A2F Tri-Star Triple Certified Flameproof (Type 'd'), Increased Safety (Type 'e') and Restricted Breathing (Type 'nR') indoor and outdoor cable gland for use in Zone 1, Zone 2, Zone 21 and Zone 22 hazardous areas with un-armoured and braided cable providing a combined flameproof seal and environmental seal on the cable outer sheath. This product provides full compatibility with restricted breathing equipment.

The CMP A2F Tri-Star Cable Gland is suitable for use with all forms of equipment protection permitted in Zone 1, Zone 2, Zone 21 & Zone 22 provided always that the prevailing code of practice for selection and installation is observed, e.g. IEC 60079-14.

TECHNICAL DATA	
Type	A2F
Design Specification	BS 6121: Part 1: 1989, EN 50262:1999
ATEX Certification	SIRA06ATEX1097X
Code of Protection Category	ATEX (Ex) II 2/3 GD Ex d IIC, Ex e II, Ex nR II, Ex tD A21 IP66, - Equipment Zone 1, Zone 2, Zone 21, & Zone 22 - Gas Groups IIA, IIB, IIC, ATEX (Ex) IM2, Ex d I, Ex e I
Compliance Standards	EN 60079-0:2004, EN 60079-1:2004, EN 60079-7:2003, EN 60079-15:2003, EN 61241-0:2004 EN 61241-1:2004
IECEX Approval Number	IECEX SIR 06.0039X
Code of Protection Category	Ex d IIC, Ex e II, Ex nR II, Ex tD A21 IP66, Ex d I, Ex e I
Compliance Standards	IEC 60079-0:2004, IEC 60079-1:2003, IEC 60079-7:2001, IEC 60079-15:2005, IEC 61241-0:2004, IEC 61241-1:2004
CSA Approval Certificate Number	1211841
CSA Code of Protection Category	Ex d IIC, Ex e II, Enclosure Type 4X, Class II Div 2 Groups EFG
CSA Compliance Standards	CSA C22.2 No. 174-M1984, CAN/CSA E79-0-95, CAN/CSA-C22.2 No. 0-M1991, CAN/CSA E79-1-95
INMETRO Approval Number	MC, AEX-7619-X
Code of Protection Category	BR - Ex d IIC / BR - Ex e II / IP66W
Compliance Standards	IEC 60079-0/00, IEC 60079-1/01, IEC 60079-7/2001, NBR/IEC 60529/2005
GOST R Certificate Number	POCC GB.ГБ05.В01912
Code of Protection Category	Ex d IIC U / Ex e II U
Compliance Standards	ГОСТ P 52350.0-2005, ГОСТ P 52350.1-2005, ГОСТ P 52350.7-2005
GGTN Permit Number	PPC 00-18262
GOST K Certificate Number	KZ7500052.05.01.00063
RoK Permit for Use Number	08-067693
Lloyds Approval Number	01/00172
DNV Approval Number	E-6157
ABS Approval Number	01-LD 234401-PDA
Continuous Operating Temperature	-60° to +130°
Ingress Protection Rating	IP66, IP67, IP68
Deluge Protection Compliance	DTS01 : 91
Cable Gland Material	Brass, Electroless Nickel Plated Brass, Aluminium, Stainless Steel
Seal Material	CMP SOLO LSF Thermoplastic Elastomer
Cable Type	Unarmoured & Braided
Sealing Technique	CMP Displacement Seal
Sealing Area(s)	Cable Outer Sheath
Optional Accessories	Locknut, Shroud, Entry Thread Seal, Serrated Washer, Earth Tag, Adaptor/Reducer

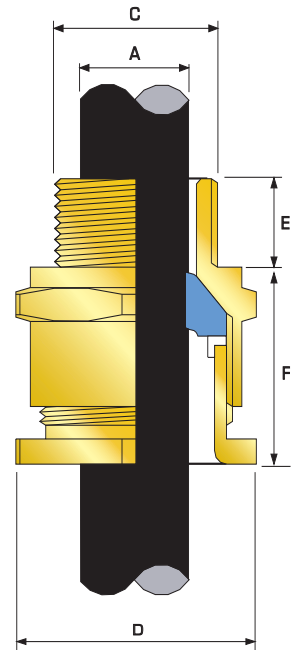

Cable Gland Selection Table

Cable Gland Size	Available Entry Threads 'C'			Minimum Thread Length 'E'	Overall Cable Diameter 'A'		Across Flats 'D'	Across Corners 'D'	Nominal Protrusion Length 'F'	Ordering Reference (Brass Metric) #	PVC Shroud Reference*	Cable Gland Weight (Kgs)
	Standard		Option		Min	Max	Max	Max				
	Metric	NPT	NPT									
20S/16	M20	1/2"	3/4"	15.0	3.2	8.7	24.0	26.6	21.0	20S16A2F1RA	PVC04	0.054
20S	M20	1/2"	3/4"	15.0	6.1	11.7	24.0	26.6	21.0	20SA2F1RA	PVC04	0.054
20	M20	1/2"	3/4"	15.0	6.5	14.0	27.0	31.0	24.0	20A2F1RA	PVC05	0.059
25	M25	3/4"	1"	15.0	11.1	20.0	36.0	39.0	26.0	25A2F1RA	PVC09	0.112
32	M32	1"	1-1/4"	15.0	17.0	26.3	41.0	45.0	27.0	32A2F1RA	PVC10	0.128
40	M40	1-1/4"	1-1/2"	15.0	23.5	32.2	50.0	53.5	28.0	40A2F1RA	PVC13	0.168
50S	M50	1-1/2"	2"	15.0	31.0	38.2	55.0	61.0	29.0	50SA2F1RA	PVC14	0.224
50	M50	2"	2-1/2"	15.0	35.6	44.1	60.0	66.0	30.0	50A2F1RA	PVC17	0.231
63S	M63	2"	2-1/2"	15.0	41.5	50.0	70.0	77.5	30.0	63SA2F1RA	PVC20	0.360
63	M63	2-1/2"	3"	15.0	47.2	56.0	75.0	84.0	30.0	63A2F1RA	PVC22	0.344
75S	M75	2-1/2"	3"	15.0	54.0	62.0	79.0	87.0	32.0	75SA2F1RA	PVC24	0.466
75	M75	3"	3-1/2"	15.0	61.1	68.0	84.0	94.0	32.0	75A2F1RA	PVC26	0.395
90	M90	3"	3-1/2"	15.0	66.6	80.0	108.0	120.0	44.0	90A2F1RA	PVC31	1.346
100	M100	4"	-	15.0	76.0	91.0	122.0	138.0	48.0	100A2F1RA	150/50HST	1.575
115	M115	-	-	15.0	86.0	98.0	138.0	148.0	55.0	115A2F1RA	180/60HST	2.322
130	M130	-	-	15.0	97.0	115.0	154.0	178.0	62.0	130A2F1RA	180/60HST	3.400

All dimensions in millimetres

Note: *LSF Shrouds also available on request. *Marine approvals including Lloyds, DNV & ABS are also available from CMP Products. # Other thread forms are available.

SS2K CABLE GLAND

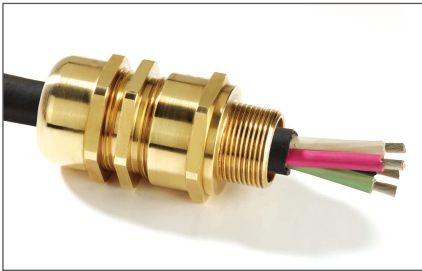

Type SS2K Tri-Star Flameproof Ex d, Increased Safety Ex e and Restricted Breathing Ex nR Cable Gland

CMP Type SS2K Tri-Star Triple Certified Flameproof (Type 'd'), Increased Safety (Type 'e') and Restricted Breathing (Type 'nR') indoor and outdoor cable gland for use in Zone 1, Zone 2, Zone 21 and Zone 22 hazardous areas with un-armoured cables. This cable gland provides a flameproof seal on the cable inner sheath (or outer sheath of single sheathed cable) and a secondary environmental seal on the cable outer sheath. This cable gland can also be used with braided cables where the sealing is made on the cable overall diameter, when this arrangement is permitted by the prevailing installation code of practice, and the metallic braid is earthed inside the equipment. This product provides full compatibility with restricted breathing equipment and affords extra stability and superior resistance to cable pull out.

The CMP SS2K Tri-Star Cable Gland is suitable for use with all forms of equipment protection permitted in Zone 1, Zone 2, Zone 21 & Zone 22 provided always that the prevailing code of practice for selection and installation is observed, e.g. IEC 60079-14.

TECHNICAL DATA	
Type	SS2K
Design Specification	BS 6121:Part 1:1989, EN 50262:1999
ATEX Certification	SIRA06ATEX1097X
Code of Protection Category	ATEX (Ex) II 2 GD Ex d IIC, Ex e II, Ex nR II, Ex tD A21 IP66, - Equipment Zone 1, Zone 2, Zone 21, & Zone 22 - Gas Groups IIA, IIB, IIC, ATEX (Ex) IM2, Ex d I, Ex e I
Compliance Standards	EN 60079-0:2004, EN 60079-1:2004, EN 60079-7:2003, EN 60079-15:2003, EN 61241-0:2004, EN 61241-1:2004
IECEx Approval Number	IECEx SIR 06.0041X
Code of Protection Category	Ex d IIC, Ex e II, Ex nR II, Ex tD A21 IP66, Ex d I, Ex e I
Compliance Standards	IEC 60079-0:2004, IEC 60079-1:2003, IEC 60079-7:2001, IEC 60079-15:2005, IEC 61241-0:2004, IEC 61241-1:2004
GOST R Certificate Number	POCC GB. ГБ05.В01912
Code of Protection Category	Ex d IIC U / Ex e II U
Compliance Standards	ГОСТ P 52350.0-2005, ГОСТ P 52350.1-2005, ГОСТ P 52350.7-2005
GGTN Permit Number	PPT 00-18262
GOST K Certificate Number	KZ7500052.05.01.00063
RoK Permit for Use Number	08-067693
Lloyds Approval Number	01/00172
DNV Approval Number	E-6157
ABS Approval Number	01-LD 234401-PDA
Continuous Operating Temperature	-60°C to +130°C
Ingress Protection Rating	IP66, IP67, IP68
Ingress Protection Document	5046 C549K
Deluge Protection Compliance	DTS01 : 91
Deluge Protection Document	5046 C549K-D
Cable Gland Material	Brass, Electroless Nickel Plated Brass, Aluminium, Stainless Steel
Seal Material	CMP SOLO LSF Thermoplastic Elastomer
Cable Type	Unarmoured & Braided
Sealing Technique	CMP Displacement Seal
Sealing Area(s)	Cable Inner Bedding and Cable Outer Sheath, or Double Seal on Cable Outer Sheath
Optional Accessories	Locknut, Shroud, Entry Thread Seal, Serrated Washer, Earth Tag, Adaptor/Reducer

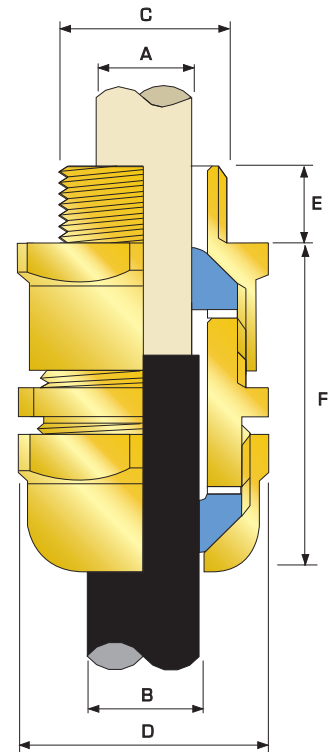

Cable Gland Selection Table

Cable Gland Size	Available Entry Threads 'C'			Minimum Thread Length 'E'	Overall Cable Diameter 'A'		Overall Cable Diameter 'B'		Across Flats 'D'	Across Corners 'D'	Nominal Protrusion Length 'F'	Ordering Reference (Brass Metric) #	PVC Shroud Reference*	Cable Gland Weight (Kgs)
	Standard	Option			Min	Max	Min	Max						
	Metric	NPT	NPT							Max	Max			
20S/16	M20	1/2"	3/4"	15.0	3.2	8.7	3.2	8.7	24.0	26.6	42.0	20S16SS2K1RA	PVC04	0.072
20S	M20	1/2"	3/4"	15.0	6.1	11.7	6.1	11.7	24.0	26.6	42.0	20SSS2K1RA	PVC04	0.072
20	M20	1/2"	3/4"	15.0	6.5	14.0	6.5	14.0	27.0	31.0	47.0	20SS2K1RA	PVC05	0.079
25	M25	3/4"	1"	15.0	11.1	20.0	11.1	20.0	36.0	39.0	56.0	25SS2K1RA	PVC09	0.149
32	M32	1"	1-1/4"	15.0	17.0	26.3	17.0	26.3	41.0	45.0	58.0	32SS2K1RA	PVC10	0.170
40	M40	1-1/4"	1-1/2"	15.0	23.5	32.2	23.5	32.2	50.0	53.5	60.0	40SS2K1RA	PVC13	0.224
50S	M50	1-1/2"	2"	15.0	31.0	38.2	31.0	38.2	55.0	61.0	62.0	50SSS2K1RA	PVC14	0.298
50	M50	2"	2-1/2"	15.0	35.6	44.1	35.6	44.1	60.0	66.0	64.0	50SS2K1RA	PVC17	0.308
63S	M63	2"	2-1/2"	15.0	41.5	50.0	41.5	50.0	70.0	77.5	66.0	63SSS2K1RA	PVC20	0.480
63	M63	2-1/2"	3"	15.0	47.2	56.0	47.2	56.0	75.0	84.0	67.0	63SS2K1RA	PVC22	0.458
75S	M75	2-1/2"	3"	15.0	54.0	62.0	54.0	62.0	79.0	87.0	68.0	75SSS2K1RA	PVC24	0.621
75	M75	3"	3-1/2"	15.0	61.1	68.0	61.1	68.0	84.0	94.0	70.0	75SS2K1RA	PVC26	0.526
90	M90	3"	3-1/2"	15.0	66.6	80.0	66.6	79.4	108.0	120.0	75.0	90SS2K1RA	PVC31	1.795
100	M100	4"	-	15.0	76.0	91.0	76.0	91.0	122.0	138.0	81.0	100SS2K1RA	150/50HST	2.100
115	M115	-	-	15.0	86.0	98.0	86.0	98.0	138.0	148.0	85.0	115SS2K1RA	180/60HST	3.096
130	M130	-	-	15.0	97.0	115.0	97.0	115.0	154.0	178.0	92.0	130SS2K1RA	180/60HST	4.530

All dimensions in millimetres

Note: *LSF Shrouds also available on request. *Marine approvals including Lloyds, DNV & ABS are also available from CMP Products. # Other thread forms are available.



SS2KPB CABLE GLAND

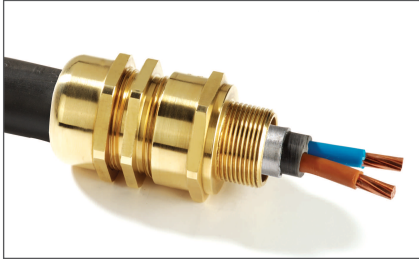

Type SS2KPB Tri-Star Flameproof Ex d, Increased Safety Ex e and Restricted Breathing Ex nR Cable Gland

CMP Type SS2KPB Tri-Star Triple Certified Flameproof (Type 'd'), Increased Safety (Type 'e') and Restricted Breathing (Type 'nR') indoor and outdoor cable gland for use in Zone 1, Zone 2, Zone 21 and Zone 22 hazardous areas with lead sheathed or lead covered un-armoured cables. This cable gland provides a flameproof seal on the cable inner lead sheath and a secondary environmental seal on the cable outer sheath. Suitable for use Zone 1, Zone 2, Zone 21 and Zone 22 hazardous areas, this cable gland design affords extra stability and superior resistance to cable pull out. This product provides full compatibility with restricted breathing equipment and affords extra stability and superior resistance to cable pull out.

The CMP SS2KPB Tri-Star Cable Gland is suitable for use with all forms of equipment protection permitted in Zone 1, Zone 2, Zone 21 & Zone 22 provided always that the prevailing code of practice for selection and installation is observed, e.g. IEC 60079-14.

TECHNICAL DATA	
Type	SS2KPB
Design Specification	BS 6121:Part 1:1989, EN 50262:1999
ATEX Certification	SIRA06ATEX1097X
Code of Protection Category	ATEX (Ex) II 2 GD Ex d IIC, Ex e II, Ex nR II, Ex tD A21 IP66, - Equipment Zone 1, Zone 2, Zone 21, & Zone 22 - Gas Groups IIA, IIB, IIC
Compliance Standards	EN 60079-0:2004, EN 60079-1:2004, EN 60079-7:2003, EN 60079-15:2003, EN 61241-0:2004, EN 61241-1:2004
IECEx Approval Number	IECEx SIR 06.0041X
Code of Protection Category	Ex d IIC, Ex e II, Ex nR II, Ex tD A21 IP66, Ex dI, Ex eI
Compliance Standards	IEC 60079-0:2004, IEC 60079-1:2003, IEC 60079-7:2001, IEC 60079-15:2005, IEC 61241-0:2004, IEC 61241-1:2004
GOST R Certificate Number	POCC GB. ГБ 05.В01912
Code of Protection Category	Ex d IIC U / Ex e II U
Compliance Standards	ГОСТ P 52350.0-2005,ГОСТ P 52350.1-2005, ГОСТ P 52350.7-2005
GGTN Permit Number	PPC 00-18262
GOST K Certificate Number	KZ7500052.05.01.00063
RoK Permit for Use Number	08-067693
Lloyds Approval Number	01/00172
DNV Approval Number	E-6157
ABS Approval Number	01-LD 234401-PDA
Continuous Operating Temperature	-60° to +130°
Ingress Protection Rating	IP66, IP67, IP68
Ingress Protection Document	5046 C549K
Deluge Protection Compliance	DTS01 : 91
Deluge Protection Document	5046 C549K-D
Cable Gland Material	Brass, Electroless Nickel Plated Brass, Aluminium, Stainless Steel
Seal Material	CMP SOLO LSF Thermoplastic Elastomer
Cable Type	Lead Sheathed or Lead Covered & Unarmoured
Sealing Technique	CMP Displacement Seal
Sealing Area(s)	Cable Inner Lead Sheath or Lead Covering and Cable Outer Sheath
Optional Accessories	Locknut, Shroud, Entry Thread Seal, Serrated Washer, Earth Tag, Adaptor/Reducer

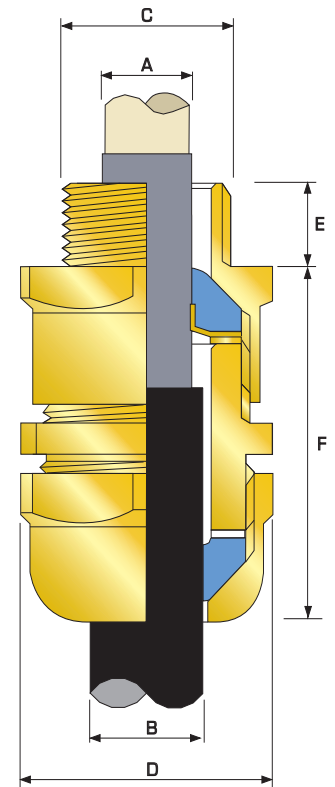

Cable Gland Selection Table

Cable Gland Size	Available Entry Threads 'C'			Minimum Thread Length 'E'	Diameter Over Lead Sheath 'A'		Overall Cable Diameter 'B'		Across Flats 'D'	Across Corners 'D'	Nominal Protrusion Length 'F'	Ordering Reference (Brass Metric) #	PVC Shroud Reference*	Cable Gland Weight (Kgs)
	Standard		Option		Min	Max	Min	Max						
	Metric	NPT	NPT											
20S/16	M20	1/2"	3/4"	15.0	3.2	8.7	3.2	8.7	24.0	26.6	42.0	20S16SS2KPB1RA	PVC04	0.072
20S	M20	1/2"	3/4"	15.0	6.1	11.7	6.1	11.7	24.0	26.6	42.0	20SSS2KPB1RA	PVC04	0.072
20	M20	1/2"	3/4"	15.0	6.5	14.0	6.5	14.0	27.0	31.0	47.0	20SS2KPB1RA	PVC05	0.079
25	M25	3/4"	1"	15.0	11.1	20.0	11.1	20.0	36.0	39.0	56.0	25SS2KPB1RA	PVC09	0.149
32	M32	1"	1-1/4"	15.0	17.0	26.3	17.0	26.3	41.0	45.0	58.0	32SS2KPB1RA	PVC10	0.170
40	M40	1-1/4"	1-1/2"	15.0	23.5	32.2	23.5	32.2	50.0	53.5	60.0	40SS2KPB1RA	PVC13	0.224
50S	M50	1-1/2"	2"	15.0	31.0	38.2	31.0	38.2	55.0	61.0	62.0	50SSS2KPB1RA	PVC14	0.298
50	M50	2"	2-1/2"	15.0	35.6	44.1	35.6	44.1	60.0	66.0	64.0	50SS2KPB1RA	PVC17	0.308
63S	M63	2"	2-1/2"	15.0	41.5	50.0	41.5	50.0	70.0	77.5	66.0	63SSS2KPB1RA	PVC20	0.480
63	M63	2-1/2"	3"	15.0	47.2	56.0	47.2	56.0	75.0	84.0	67.0	63SS2KPB1RA	PVC22	0.458
75S	M75	2-1/2"	3"	15.0	54.0	62.0	54.0	62.0	79.0	87.0	68.0	75SSS2KPB1RA	PVC24	0.621
75	M75	3"	3-1/2"	15.0	61.1	68.0	61.1	68.0	84.0	94.0	70.0	75SS2KPB1RA	PVC26	0.526
90	M90	3"	3-1/2"	15.0	66.6	80.0	66.6	79.4	108.0	120.0	75.0	90SS2KPB1RA	PVC31	1.795
100	M100	4"	-	15.0	76.0	91.0	76.0	91.0	122.0	138.0	81.0	100SS2KPB1RA	150/50HST	2.100
115	M115	-	-	15.0	86.0	98.0	86.0	98.0	138.0	148.0	85.0	115SS2KPB1RA	180/60HST	3.096
130	M130	-	-	15.0	97.0	115.0	97.0	115.0	154.0	178.0	92.0	130SS2KPB1RA	180/60HST	4.530

All dimensions in millimetres

Note: *LSF Shrouds also available on request. Marine approvals including Lloyds, DNV & ABS are also available from CMP Products.
Other thread forms are available.

SS2KTA CABLE GLAND

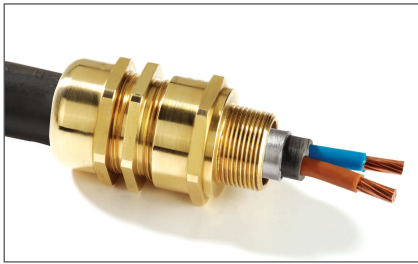

Type SS2KTA Increased Safety Ex e Cable Gland

CMP Type SS2KTA Increased Safety (Type 'e') indoor and outdoor cable gland for use in Zone 1, Zone 2, Zone 21 and Zone 22 hazardous areas with Steel Tape Armour cables. This cable gland provides a flameproof seal on the cable inner lead sheath and a secondary environmental seal on the cable outer sheath. Suitable for use Zone 1, Zone 2, Zone 21 and Zone 22 hazardous areas, this cable gland design affords extra stability and superior resistance to cable pull out.

The CMP SS2KTA Cable Gland is suitable for use with Increased safety Type e and Flameproof Type d enclosures that are equipped with a secondary Increased Safety Type e terminal enclosure (i.e. Ex de) provided always that no source of ignition prevails and the prevailing code of practice for selection and installation is observed, e.g. IEC 60079-14.

TECHNICAL DATA	
Type	SS2KTA
Design Specification	BS 6121:Part 1:1989, EN 50262:1999
ATEX Certification	SIRA06ATEX1097X
Code of Protection Category	ATEX (Ex) II 2 GD Ex e II, Ex tD A21 IP66, - Equipment Zone 1, Zone 2, Zone 21, & Zone 22 - Gas Groups IIA, IIB, IIC
Compliance Standards	EN 60079-0:2004, EN 60079-7:2003, EN 61241-0:2004, EN 61241-1:2004
IECEx Approval Number	IECEx SIR 06.0041X
Code of Protection Category	Ex e II, Ex tD A21 IP66
Compliance Standards	IEC 60079-0:2004, IEC 60079-7:2001, IEC 61241-0:2004, IEC 61241-1:2004
GOST R Certificate Number	POCC GB. ГБ05.В01912
Code of Protection Category	Ex e II U
Compliance Standards	ГОСТ P 52350.0-2005,ГОСТ P 52350.7-2005
GGTN Permit Number	PPC 00-18262
GOST K Certificate Number	KZ7500052.05.01.00063
RoK Permit for Use Number	08-067693
Lloyds Approval Number	01/00172
DNV Approval Number	E-6157
ABS Approval Number	01-LD 234401-PDA
Continuous Operating Temperature	-60° to +130°
Ingress Protection Rating	IP66, IP67, IP68
Ingress Protection Document	5046 C549K
Deluge Protection Compliance	DTS01 : 91
Deluge Protection Document	5046 C549K-D
Cable Gland Material	Brass, Electroless Nickel Plated Brass, Aluminium, Stainless Steel
Seal Material	CMP SOLO LSF Thermoplastic Elastomer
Cable Type	Steel Tape Armour
Sealing Technique	CMP Displacement Seal
Sealing Area(s)	Steel Tape Armour and Cable Outer Sheath
Optional Accessories	Locknut, Shroud, Entry Thread Seal, Serrated Washer, Earth Tag, Adaptor/Reducer

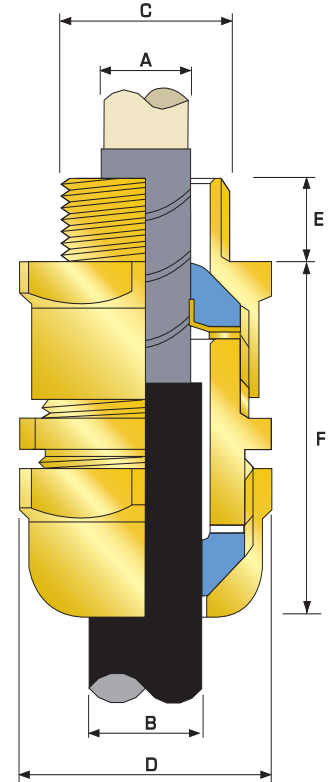

Cable Gland Selection Table

Cable Gland Size	Available Entry Threads 'C'			Minimum Thread Length 'E'	Diameter Over Tape Armour 'A'		Overall Cable Diameter 'B'		Across Flats 'D'	Across Corners 'D'	Nominal Protrusion Length 'F'	Ordering Reference (Brass Metric) #	PVC Shroud Reference*	Cable Gland Weight (Kgs)
	Standard	Option			Min	Max	Min	Max						
	Metric	NPT	NPT											
20S/16	M20	1/2"	3/4"	15.0	3.2	8.7	3.2	8.7	24.0	26.6	42.0	20S16SS2KTA1RA	PVC04	0.072
20S	M20	1/2"	3/4"	15.0	6.1	11.7	6.1	11.7	24.0	26.6	42.0	20SSS2KTA1RA	PVC04	0.072
20	M20	1/2"	3/4"	15.0	6.5	14.0	6.5	14.0	27.0	31.0	47.0	20SS2KTA1RA	PVC05	0.079
25	M25	3/4"	1"	15.0	11.1	20.0	11.1	20.0	36.0	39.0	56.0	25SS2KTA1RA	PVC09	0.149
32	M32	1"	1-1/4"	15.0	17.0	26.3	17.0	26.3	41.0	45.0	58.0	32SS2KTA1RA	PVC10	0.170
40	M40	1-1/4"	1-1/2"	15.0	23.5	32.2	23.5	32.2	50.0	53.5	60.0	40SS2KTA1RA	PVC13	0.224
50S	M50	1-1/2"	2"	15.0	31.0	38.2	31.0	38.2	55.0	61.0	62.0	50SSS2KTA1RA	PVC14	0.298
50	M50	2"	2-1/2"	15.0	35.6	44.1	35.6	44.1	60.0	66.0	64.0	50SS2KTA1RA	PVC17	0.308
63S	M63	2"	2-1/2"	15.0	41.5	50.0	41.5	50.0	70.0	77.5	66.0	63SSS2KTA1RA	PVC20	0.480
63	M63	2-1/2"	3"	15.0	47.2	56.0	47.2	56.0	75.0	84.0	67.0	63SS2KTA1RA	PVC22	0.458
75S	M75	2-1/2"	3"	15.0	54.0	62.0	54.0	62.0	79.0	87.0	68.0	75SSS2KTA1RA	PVC24	0.621
75	M75	3"	3-1/2"	15.0	61.1	68.0	61.1	68.0	84.0	94.0	70.0	75SS2KTA1RA	PVC26	0.526
90	M90	3"	3-1/2"	15.0	66.6	80.0	66.6	79.4	108.0	120.0	75.0	90SS2KTA1RA	PVC31	1.795
100	M100	4"	-	15.0	76.0	91.0	76.0	91.0	122.0	138.0	81.0	100SS2KTA1RA	150/50HST	2.100
115	M115	-	-	15.0	86.0	98.0	86.0	98.0	138.0	148.0	85.0	115SS2KTA1RA	180/60HST	3.096
130	M130	-	-	15.0	97.0	115.0	97.0	115.0	154.0	178.0	92.0	130SS2KTA1RA	180/60HST	4.530

All dimensions in millimetres

Note: *LSF Shrouds also available on request. Marine approvals including Lloyds, DNV & ABS are also available from CMP Products.
Other thread forms are available.

A2FRC CABLE GLAND

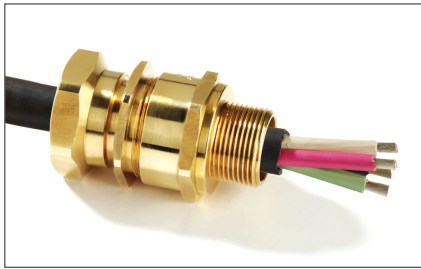

Type A2FRC Tri-Star Flameproof Ex d, Increased Safety Ex e and Restricted Breathing Ex nR Cable Gland for Conduit Connection

CMP Type A2FRC Tri-Star Triple Certified Flameproof (Type 'd'), Increased Safety (Type 'e') and Restricted Breathing (Type 'nR') indoor and outdoor conduit connection cable gland for use in Zone 1, Zone 2, Zone 21 and Zone 22 hazardous areas with un-armoured cable housed in rigid or flexible conduit systems. The cable gland provides a combined flameproof seal and environmental seal on the cable outer sheath. This product provides full compatibility with restricted breathing equipment.

The CMP A2FRC Tri-Star Cable Gland is suitable for use with all forms of equipment protection permitted in Zone 1, Zone 2, Zone 21 & Zone 22 provided always that the prevailing code of practice for selection and installation is observed, e.g. IEC 60079-14.

TECHNICAL DATA	
Type	A2FRC
Design Specification	BS 6121:Part 1:1989, EN 50262:1999
ATEX Certification	SIRA06ATEX1097X
Code of Protection Category	ATEX (Ex) II 2 GD Ex d IIC, Ex e II, Ex nR II, Ex tD A21 IP66, - Equipment Zone 1, Zone 2, Zone 21, & Zone 22 - Gas Groups IIA, IIB, IIC
Compliance Standards	EN 60079-0:2004, EN 60079-1:2004, EN 60079-7:2003, EN 60079-15:2003, EN 61241-0:2004, EN 61241-1:2004
IECEx Approval Number	IECEx SIR 06.0040X
Code of Protection Category	Ex d IIC, Ex e II, Ex nR II, Ex tD A21 IP66
Compliance Standards	IEC 60079-0:2004, IEC 60079-1:2003, IEC 60079-7:2001, IEC 60079-15:2005, IEC 61241-0:2004, IEC 61241-1:2004
INMETRO Approval Certificate Number	MC, AEX-7619-X
Code of Protection Category	BR - Ex d IIC / BR - Ex e II / IP66W
Compliance Standards	IEC 60079-0/00, IEC 60079-1/01, IEC 60079-7/2001, NBR/IEC 60529/2005
GOST R Certificate Number	POCC GB. Г Б 05.Б01912
Code of Protection Category	Ex d IIC U / Ex e II U
Compliance Standards	ГОСТ P 52350.0-2005,ГОСТ P 52350.1-2005, ГОСТ P 52350.7-2005
GGTN Permit Number	PPC 00-18262
GOST K Certificate Number	KZ7500052.05.01.00063
RoK Permit for Use Number	08-067693
Lloyds Approval Number	01/00172
ABS Approval Number	01-LD 234401-PDA
Continuous Operating Temperature	-60°C to +130°C
Ingress Protection Rating	IP66
Cable Gland Material	Brass, Electroless Nickel Plated Brass, Aluminium, Stainless Steel
Seal Material	CMP SOLO LSF Thermoplastic Elastomer
Cable Type	Unarmoured & Braided
Sealing Technique	CMP Displacement Seal
Sealing Area(s)	Outer Sheath
Optional Accessories	Locknut, Entry Thread Seal, Serrated Washer, Earth Tag, Adaptor/Reducer

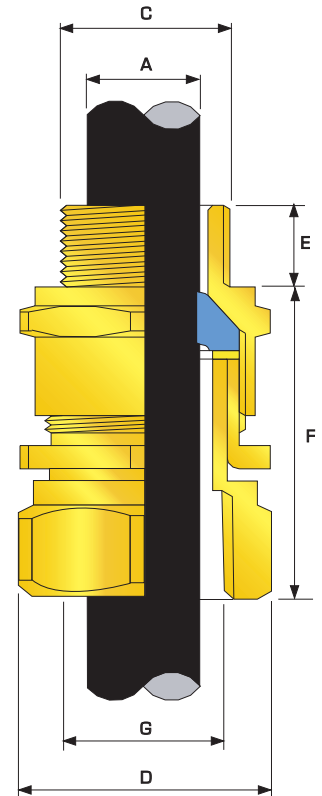

Cable Gland Selection Table



Cable Gland Size	Available Entry Threads 'C'			Minimum Thread Length 'E'	Standard Female Connection Thread 'G'	Overall Cable Diameter 'A'		Across Flats 'D'	Across Corners 'D'	Nominal Protrusion Length 'F'	Ordering Reference (Brass Metric) Metric Mx NPT #	Cable Gland Weight (Kgs)
	Standard		Option			Max	Max	Max	Max			
	Metric	NPT	NPT									
20S/16	M20	1/2"	3/4"	15.0	1/2"	3.1	8.7	24.0	26.6	21.0	20S16A2FRC1RA031	0.060
20S	M20	1/2"	3/4"	15.0	1/2"	6.1	11.7	24.0	26.6	21.0	20SA2FRC1RA031	0.075
20	M20	1/2"	3/4"	15.0	1/2"	6.5	14.0	27.0	31.0	24.0	20A2FRC1RA031	0.100
25	M25	3/4"	1"	15.0	3/4"	11.1	20.0	36.0	39.0	26.0	25A2FRC1RA032	0.232
32	M32	1"	1-1/4"	15.0	1"	17.0	26.3	41.0	45.0	27.0	32A2FRC1RA033	0.400
40	M40	1-1/4"	1-1/2"	15.0	1-1/4"	23.5	32.2	50.0	53.5	28.0	40A2FRC1RA034	0.560
50S	M50	1-1/2"	2"	15.0	1-1/2"	31.0	38.2	55.0	61.0	29.0	50SA2FRC1RA035	0.600
50	M50	2"	2-1/2"	15.0	2"	35.6	44.1	60.0	66.0	30.0	50A2FRC1RA036	0.590
63S	M63	2"	2-1/2"	15.0	2"	41.5	50.0	70.0	77.5	30.0	63SA2FRC1RA036	0.720
63	M63	2-1/2"	3"	15.0	2-1/2"	47.2	56.0	75.0	84.0	30.0	63A2FRC1RA037	0.690
75S	M75	2-1/2"	3"	15.0	2-1/2"	54.0	62.0	79.0	87.0	32.0	75SA2FRC1RA037	0.850
75	M75	3"	3-1/2"	15.0	3"	61.1	68.0	84.0	94.0	32.0	75A2FRC1RA038	0.800
90	M90	3"	3-1/2"	15.0	3"	66.6	80.0	108.0	120.0	44.0	90A2FRC1RA038	1.120

All dimensions in millimetres

Note: † Please specify male and female connection threads required when ordering. Marine approvals including Lloyds, DNV & ABS are also available from CMP Products.
Other thread forms are available.

C2K CABLE GLAND

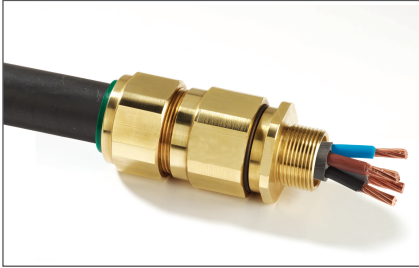

Type C2K Increased Safety Ex e Cable Gland

CMP Type C2K Increased Safety (Type 'e') cable gland for use in Zone 1, Zone 2, Zone 21 and Zone 22 Hazardous Areas with all types of armoured cable providing an environmental seal on the cable outer sheath. The cable gland being suitable for use with armoured cables provides mechanical cable retention and electrical continuity via armour wire termination. A reversible armour cone and AnyWay universal clamping ring arrangement allows the cable to be easily disconnected from the equipment, for maintenance and change out etc. This feature also facilitates remote make off procedures when the termination is to be conducted in confined spaces or in areas of restricted access.

The CMP C2K Cable Gland is suitable for use with Increased Safety Type e and Flameproof Type d enclosures that are equipped with a secondary Increased Safety Type e terminal enclosure (i.e. Ex de) provided always that no source of ignition prevails and the prevailing code of practice for selection and installation is observed, e.g. IEC 60079-14.

TECHNICAL DATA	
Type	C2K
Design Specification	BS 6121:Part 1:1989, EN 50262:1999
ATEX Certification	SIRA06ATEX1097X
Code of Protection Category	ATEX $\text{Ex II 2 GD Ex e II, Ex tD A21 IP66}$, - Equipment Zone 1, Zone 2, Zone 21, & Zone 22 - Gas Groups IIA, IIB, IIC
Compliance Standards	EN 60079-0:2004, EN 60079-7:2003, EN 61241-0:2004, EN 61241-1:2004
IECEX Approval Number	IECEX SIR 06.0042X
Code of Protection Category	Ex e II, Ex tD A21 IP66
Compliance Standards	IEC 60079-0:2004, IEC 60079-7:2001, IEC 61241-0:2004, IEC 61241-1:2004
Lloyds Approval Number	01/00171
INMETRO Approval Certificate Number	MC, AEX-7620-X
Code of Protection Category	BR - Ex e II / IP66W
Compliance Standards	IEC 60079-0/00, IEC 60079-7/2001, NBR/IEC 60529/2005
GOST R Certificate Number	POCC GB.ГБ05.В01912
Code of Protection Category	Ex e II U
Compliance Standards	ГОСТ Р 52350.0-2005,ГОСТ Р 52350.7-2005
GOST K Certificate Number	KZ7500052.05.01.00063
RoK Permit for Use Number	08-067693
DNV Approval Number	E-6157
ABS Approval Number	01-LD 234401-PDA
Continuous Operating Temperature	-60°C to +130°C
Ingress Protection Rating	IP66, IP67, IP68
Deluge Protection Compliance	DTS01 : 91
Cable Gland Material	Brass, Electroless Nickel Plated Brass, Aluminium, Stainless Steel
Seal Material	CMP SOLO LSF Thermoplastic Elastomer
Cable Type	Single Wire Armour (SWA), Aluminium Wire Armour (AWA), Pliable Wire Armour (PWA), Steel Tape Armour (STA), Wire Braid Armour, Aluminium Strip Armour (ASA), Screened Flexible Wire Braid (e.g. CY / SY), Armored & Jacketed
Armour Clamping	Reversible Armour Cone & AnyWay Universal Clamping Ring
Sealing Technique	Unique CMP "LRS"™ Outer Seal (Load Retention Seal)
Sealing Area(s)	Cable Outer Sheath
Optional Accessories	Locknut, Adaptor/Reducer, Earth Tag, Shroud, Entry Thread Seal, Serrated Washer

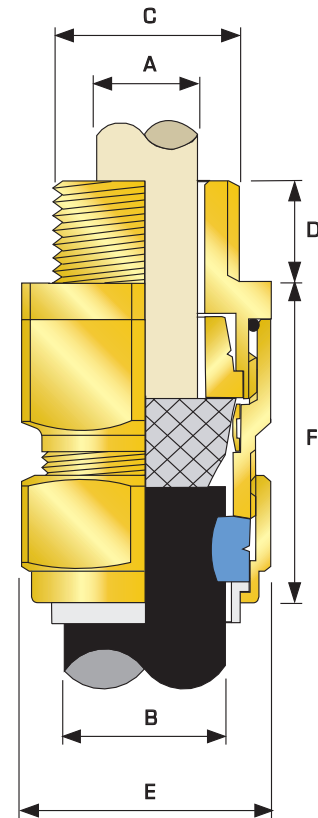

Cable Gland Selection Table

Cable Gland Size	Available Entry Threads 'C'			Minimum Thread Length 'E'	Cable Bedding Diameter 'A'	Overall Cable Diameter 'B'		Armour Range †			Across Flats 'D'	Across Corners 'D'	Nominal Protrusion Length 'F'	Ordering Reference (Brass Metric) #	PVC Shroud Reference *	Cable Gland Weight (Kgs)	
	Standard	Option				Min	Max	Grooved Cone		Stepped Cone							
	Metric	NPT	NPT			Min	Max	Min	Max	Min	Max	Max	Max				
20S/16	M20	1/2"	3/4"	15.0	8.7	6.1	11.5	0.0	1.0	0.9	1.0	24.0	26.6	47.0	20S16C2K1RA	PVC04	0.132
20S	M20	1/2"	3/4"	15.0	11.7	9.5	15.9	0.0	1.0	0.9	1.25	24.0	26.6	47.0	206C2K1RA	PVC04	0.132
20	M20	1/2"	3/4"	15.0	14.0	12.5	20.9	0.0	1.0	0.9	1.25	30.5	33.3	50.0	20C2K1RA	PVC06	0.194
25S	M25	3/4"	1"	15.0	20.0	14.0	22.0	0.0	1.0	1.25	1.6	37.5	40.5	55.0	25SC2K1RA	PVC09	0.306
25	M25	3/4"	1"	15.0	20.0	18.2	26.2	0.0	1.0	1.25	1.6	37.5	40.5	55.0	25C2K1RA	PVC09	0.306
32	M32	1"	1-1/4"	15.0	26.3	23.7	33.9	0.0	1.0	1.6	2.0	46.0	51.0	58.0	32C2K1RA	PVC11	0.468
40	M40	1-1/4"	1-1/2"	15.0	32.2	27.9	40.4	0.0	1.0	1.6	2.0	55.0	61.0	58.0	40C2K1RA	PVC15	0.678
50S	M50	1-1/2"	2"	15.0	38.2	35.2	46.7	0.0	1.0	2.0	2.5	60.0	66.5	58.0	50SC2K1RA	PVC18	0.750
50	M50	2"	2-1/2"	15.0	44.1	40.4	53.1	0.0	1.0	2.0	2.5	70.0	78.6	60.0	50C2K1RA	PVC21	1.044
63S	M63	2"	2-1/2"	15.0	50.0	45.6	59.4	0.0	1.0	2.0	2.5	75.0	83.2	70.0	63SC2K1RA	PVC23	1.074
63	M63	2-1/2"	3"	15.0	56.0	54.6	65.9	0.0	1.0	2.0	2.5	80.0	89.0	70.0	63C2K1RA	PVC25	1.280
75S	M75	2-1/2"	3"	15.0	62.0	59.0	72.1	0.0	1.0	2.0	2.5	89.0	101.6	80.0	75SC2K1RA	PVC28	1.860
75	M75	3"	3-1/2"	15.0	68.0	66.7	78.5	0.0	1.0	2.0	2.5	99.0	111.1	82.0	75C2K1RA	PVC30	2.550
90	M90	3"	3-1/2"	15.0	80.0	76.2	90.4	0.0	1.6	3.15	3.15	114.0	128.6	96.0	90C2K1RA	PVC32	3.650
100	M100	4"	-	15.0	91.0	86.1	101.5	0.0	1.6	3.15	4.0	123.0	138.0	106.0	100C2K1RA	150/50HST	4.050
115	M115	-	-	15.0	98.0	101.5	110.3	0.0	1.6	3.15	4.0	133.4	147.6	115.0	115C2K1RA	180/60HST	4.800
130	M130	-	-	15.0	115.0	114.2	123.3	0.0	1.6	3.15	4.0	146.1	161.9	125.0	130C2K1RA	180/60HST	5.300

All dimensions in millimetres

Note: Alternative armour clamping range available for non-standard armour sizes. Marine approvals including Lloyds, DNV & ABS are also available from CMP Products.
Other thread forms are available.

CWe CABLE GLAND

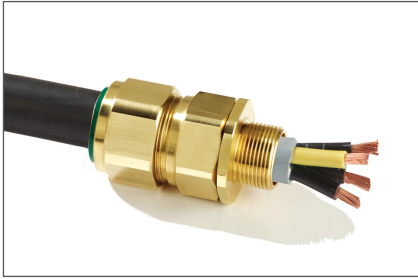

CWe Increased Safety Ex e Cable Gland

CMP Type CWe Increased Safety (Type 'e') cable gland for use in Zone 1, Zone 2, Zone 21 and Zone 22 Hazardous Areas with Single Wire Armour (SWA) cable providing an environmental seal on the cable outer sheath. The cable gland being suitable for armoured cables, provides mechanical cable retention and electrical continuity via armour wire termination. A detachable armour cone and AnyWay universal clamping ring arrangement allows the cable to be easily disconnected from the equipment, for maintenance and change out etc., and re-connected with the same consummate ease. This feature also facilitates remote make off procedures when the termination is to be conducted in confined spaces or in areas of restricted access.

The CMP CWe Cable Gland is suitable for use with Increased Safety Type e and Flameproof Type d enclosures that are equipped with a secondary Increased Safety Type e terminal enclosure (i.e. Ex de) provided always that no source of ignition prevails and the prevailing code of practice for selection and installation is observed, e.g. IEC 60079-14.

TECHNICAL DATA	
Type	CWe
Design Specification	BS 6121:Part 1:1989, EN 50262:1999
ATEX Certification	SIRA06ATEX1097X
Code of Protection Category	ATEX (Ex) II 2 GD Ex e II, Ex tD A21 IP66, Equipment Zone 1, Zone 2, Zone 21, & Zone 22 - Gas Groups IIA, IIB, IIC
Compliance Standards	EN 60079-0:2004, EN 60079-7:2003, EN 61241-0:2004, EN 61241-1:2004
IECEX Approval Number	IECEX SIR 06.0042X
Code of Protection Category	Ex e II, Ex tD A21 IP66
Compliance Standards	IEC 60079-0:2004, IEC 60079-7:2001, IEC 61241-0:2004, IEC 61241-1:2004
GOST R Certificate Number	POCC GB. ГБ 05.Б01912
INMETRO Approval Certificate Number	MC, AEX-7618-X
Code of Protection Category	BR - Ex e II / IP66W
Compliance Standards	IEC 60079-0/00, IEC 60079-7/2001, NBR/IEC 60529/2005
Code of Protection Category	Ex e II U
Compliance Standards	ГОСТ P 52350.0-2005, ГОСТ P 52350.7-2005
GGTN Permit Number	PPC 00-18262
GOST K Certificate Number	KZ7500052.05.01.00063
RoK Permit for Use Number	08-067693
Lloyds Approval Number	01/00172
DNV Approval Number	E-6157
ABS Approval Number	01-LD 234401-PDA
Continuous Operating Temperature	-60°C to +130°C
Ingress Protection Rating	IP66
Cable Gland Material	Brass, Electroless Nickel Plated Brass, Aluminium, Stainless Steel
Seal Material	CMP SOLO LSF Thermoplastic Elastomer
Cable Type	Single Wire Armour (SWA)
Armour Clamping	Detachable Armour Cone & AnyWay Universal Clamping Ring
Sealing Technique	Unique CMP "LRS"™ Outer Seal (Load Retention Seal)
Sealing Area(s)	Cable Outer Sheath
Optional Accessories	Locknut, Shroud, Entry Thread Seal, Serrated Washer, Earth Tag, Adaptor/Reducer

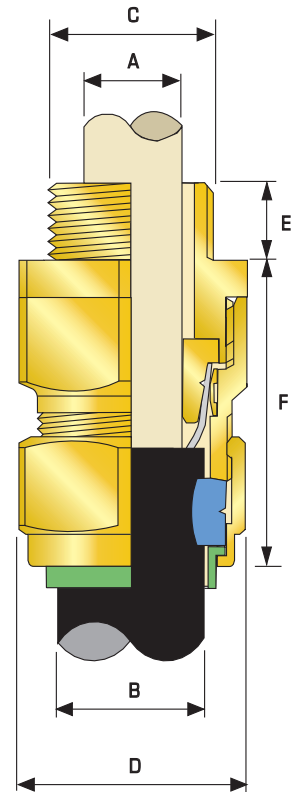

Cable Gland Selection Table

Cable Gland Size	Standard Metric Entry Threads 'C'	Minimum Thread Length 'E'	Cable Bedding Diameter 'A'		Overall Cable Diameter 'B'		Armour Range †		Across Flats 'D'	Across Corners 'D'	Nominal Protrusion Length 'F'	Ordering Reference (Brass Metric)	PVC Shroud Reference*	Cable Gland Weight (Kgs)
			Max	Min	Max	Min	Max	Min						
20S/16	M20	15.0	8.7	6.1	11.5	0.90	1.00	24.0	26.6	21.0	20S16CWe1RA	PVC04	0.054	
20S	M20	15.0	11.7	9.5	15.9	0.90	1.25	24.0	26.6	21.0	20SCWe1RA	PVC04	0.054	
20	M20	15.0	14.0	12.5	20.9	0.90	1.25	30.5	33.3	24.0	20CWe1RA	PVC06	0.059	
25S	M25	15.0	20.0	14.0	22.0	1.25	1.60	37.5	40.5	26.0	25SCWe1RA	PVC09	0.112	
25	M25	15.0	20.0	18.2	26.2	1.25	1.60	37.5	40.5	26.0	25CWe1RA	PVC09	0.128	
32	M32	15.0	26.3	23.7	33.9	1.60	2.00	46.0	51.0	27.0	32CWe1RA	PVC11	0.128	
40	M40	15.0	32.2	27.9	40.4	1.60	2.00	55.0	61.0	28.0	40CWe1RA	PVC15	0.168	
50S	M50	15.0	38.2	35.2	46.7	2.00	2.50	60.0	66.5	29.0	50SCWe1RA	PVC18	0.224	
50	M50	15.0	44.1	40.4	53.1	2.00	2.50	70.0	78.6	30.0	50CWe1RA	PVC21	0.231	
63S	M63	15.0	50.0	45.6	59.4	2.00	2.50	75.0	83.2	30.0	63SCWe1RA	PVC23	0.360	
63	M63	15.0	56.0	54.6	65.9	2.00	2.50	80.0	89.0	30.0	63CWe1RA	PVC25	0.344	
75S	M75	15.0	62.0	59.0	72.1	2.00	2.50	89.0	101.6	32.0	75SCWe1RA	PVC28	0.466	
75	M75	15.0	68.0	66.7	78.5	2.00	2.50	99.0	111.1	32.0	75CWe1RA	PVC30	0.395	
90	M90	15.0	80.0	76.2	90.4	3.15	3.15	114.0	128.6	44.0	90CWe1RA	PVC32	1.346	
100	M100	15.0	91.0	86.1	101.5	3.15	4.00	123.0	138.0	48.0	100CWe1RA	150/50HST	1.575	
115	M115	15.0	98.0	101.5	110.3	3.15	4.00	133.4	147.6	55.0	115CWe1RA	180/60HST	2.322	
130	M130	15.0	115.0	114.2	123.3	3.15	4.00	146.1	161.9	62.0	130CWe1RA	180/60HST	3.400	

All dimensions in millimetres

Note: *LSF Shrouds also available on request. Alternative armour clamping range available for non-standard armour sizes. Marine approvals including Lloyds, DNV & ABS are also available from CMP Products.

CXe CABLE GLAND

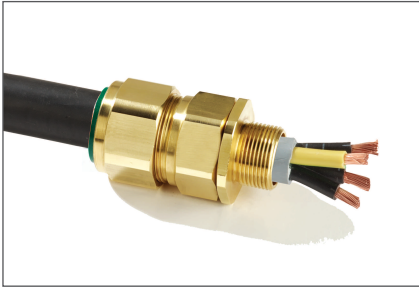

CXe Increased Safety Ex e Cable Gland

CMP Type CXe Increased Safety (Type 'e') cable gland for use in Zone 1, Zone 2, Zone 21 and Zone 22 Hazardous Areas with Braided, Pliable Wire Armour (PWA), Strip Armour and Steel Tape Armour (STA) cable providing an environmental seal on the cable outer sheath. The cable gland being suitable for armoured cables, provides mechanical cable retention and electrical continuity via armour wire termination. A detachable armour cone and AnyWay universal clamping ring arrangement allows the cable to be easily disconnected from the equipment, for maintenance and change out etc., and re-connected with the same consummate ease. This feature also facilitates remote make off procedures when the termination is to be conducted in confined spaces or in areas of restricted access.

The CMP CXe Cable Gland is suitable for use with Increased Safety Type e and Flameproof Type d enclosures that are equipped with a secondary Increased Safety Type e terminal enclosure (i.e. Ex de) provided always that no source of ignition prevails and the prevailing code of practice for selection and installation is observed, e.g. IEC 60079-14.

TECHNICAL DATA	
Type	CXe
Design Specification	BS 6121:Part 1:1989, EN 50262:1999
ATEX Certification	SIRA06ATEX1097X
Code of Protection Category	ATEX II 2 GD Ex e II, Ex tD A21 IP66, Equipment Zone 1, Zone 2, Zone 21, & Zone 22 - Gas Groups IIA, IIB, IIC
Compliance Standards	EN 60079-0:2004, EN 60079-7:2003, EN 61241-0:2004, EN 61241-1:2004
IECEX Approval Number	IECEX SIR 06.0042X
Code of Protection Category	Ex e II / Ex tD A21 IP66
Compliance Standards	IEC 60079-0:2004, IEC 60079-7:2001, IEC 61241-0:2004, IEC 61241-1:2004
GOST R Certificate Number	POCC GB. ГБ 05.Б01912
INMETRO Approval Certificate Number	MC, AEX-7618-X
Code of Protection Category	BR – Ex e II / IP66W
Compliance Standards	IEC 60079-0/00, IEC 60079-7/2001, NBR/IEC 60529/2005
Code of Protection Category	Ex e II U
Compliance Standards	ГОСТ P 52350.0-2005, ГОСТ P 52350.7-2005
GGTN Permit Number	PPC 00-18262
GOST K Certificate Number	KZ7500052.05.01.00063
RoK Permit for Use Number	08-067693
Lloyds Approval Number	01/00172
DNV Approval Number	E-6157
ABS Approval Number	01-LD 234401-PDA
Continuous Operating Temperature	-60°C to +130°C
Ingress Protection Rating	IP66
Cable Gland Material	Brass, Electroless Nickel Plated Brass, Aluminium, Stainless Steel
Seal Material	CMP SOLO LSF Thermoplastic Elastomer
Cable Type	Wire Braid Armour, Screened Flexible Wire Braid (e.g. CY / SY), Strip Armour, Pliable Wire Armour (PWA), Steel Tape Armour (STA)
Armour Clamping	Detachable Armour Cone & AnyWay Universal Clamping Ring
Sealing Technique	Unique CMP "LRS"™ Outer Seal (Load Retention Seal)
Sealing Area(s)	Cable Outer Sheath
Optional Accessories	Locknut, Shroud, Entry Thread Seal, Serrated Washer, Earth Tag, Adaptor/Reducer

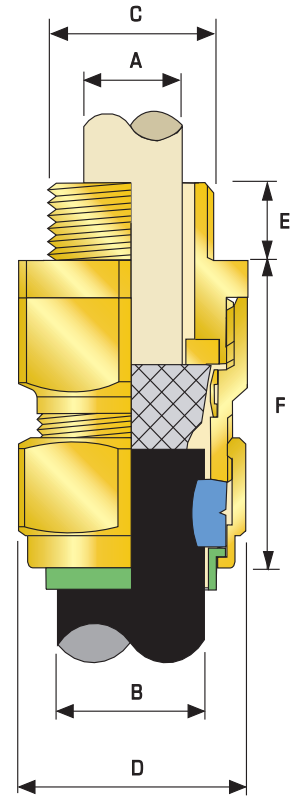

Cable Gland Selection Table

Cable Gland Size	Standard Metric Entry Threads 'C'	Minimum Thread Length 'E'	Cable Bedding Diameter 'A'	Overall Cable Diameter 'B'		Armour Range †		Across Flats 'D'	Across Corners 'D'	Nominal Protusion Length 'F'	Ordering Reference (Brass Metric)	PVC Shroud Reference*	Cable Gland Weight Kgs
				Min	Max	Min	Max						
20S16	M20	15.0	8.7	6.1	11.5	0.15	1.0	24.0	26.6	21.0	20S16CXe1RA	PVC04	0.054
20S	M20	15.0	11.7	9.5	15.9	0.15	1.0	24.0	26.6	21.0	20SCXe1RA	PVC04	0.054
20	M20	15.0	14.0	12.5	20.9	0.15	1.0	30.5	33.3	24.0	20CXe1RA	PVC06	0.059
25S	M25	15.0	20.0	14.0	22.0	0.15	1.0	37.5	40.5	26.0	25SCXe1RA	PVC09	0.112
25	M25	15.0	20.0	18.2	26.2	0.15	1.0	37.5	40.5	26.0	25CXe1RA	PVC09	0.128
32	M32	15.0	26.3	23.7	33.9	0.15	1.0	46.0	51.0	27.0	32CXe1RA	PVC11	0.128
40	M40	15.0	32.2	27.9	40.4	0.15	1.0	55.0	61.0	28.0	40CXe1RA	PVC15	0.168
50S	M50	15.0	38.2	35.2	46.7	0.15	1.0	60.0	66.5	29.0	50SCXe1RA	PVC18	0.224
50	M50	15.0	44.1	40.4	53.1	0.15	1.0	70.0	78.6	30.0	50CXe1RA	PVC21	0.231
63S	M63	15.0	50.0	45.6	59.4	0.15	1.0	75.0	83.2	30.0	63SCXe1RA	PVC23	0.360
63	M63	15.0	56.0	54.6	65.9	0.15	1.0	80.0	89.0	30.0	63CXe1RA	PVC25	0.344
75S	M75	15.0	62.0	59.0	72.1	0.15	1.0	89.0	101.6	32.0	75SCXe1RA	PVC28	0.466
75	M75	15.0	68.0	66.7	78.5	0.15	1.0	99.0	111.1	32.0	75CXe1RA	PVC30	0.395
90	M90	15.0	80.0	76.2	90.4	0.25	1.6	114.0	128.6	44.0	90CXe1RA	PVC32	1.346
100	M100	15.0	91.0	86.1	101.5	0.25	1.6	123.0	138.0	48.0	100CXe1RA	150/50HST	1.575
115	M115	15.0	98.0	101.5	110.3	0.25	1.6	133.4	147.6	55.0	115CXe1RA	180/60HST	2.322
130	M130	15.0	115.0	114.2	123.3	0.25	1.6	146.1	161.9	62.0	130CXe1RA	180/60HST	3.400

All dimensions in millimetres

Note: †Alternative armour clamping range available for non-standard armour sizes. Marine approvals including Lloyds, DNV & ABS are also available from CMP Products.

E1FU CABLE GLAND

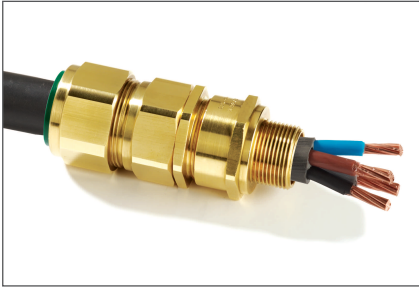

E1FU Tri-Star Flameproof Ex d, Increased Safety Ex e and Restricted Breathing Ex nR Cable Gland

CMP Type E1FU Tri-Star Triple Certified Flameproof (Type 'd'), Increased Safety (Type 'e') and Restricted Breathing (Type 'nR') indoor and outdoor cable gland for use in Zone 1, Zone 2, Zone 21 and Zone 22 Hazardous Areas with all types of armoured cable. This cable gland provides a Flameproof seal on the cable inner bedding and in addition the gas tight seal has been tested to prove compatibility with Restricted Breathing equipment. The cable gland allows mechanical cable retention and earth continuity via the cable armour termination. Separate tightening actions for the inner Displacement Seal and the Armour Termination afford maximum control over the pressure applied to the cable bedding, and also allows the effectiveness of the gas tight seal to be tested. A reversible armour cone and AnyWay clamping ring arrangement facilitates remote make off and enables the cable to be disconnected from the equipment. An environmental / load retention seal is provided on the cable outer sheath.

The CMP E1FU Tri-Star Cable Gland is suitable for use with all forms of equipment protection permitted in Zone 1, Zone 2, Zone 21 & Zone 22 provided always that the prevailing code of practice for selection and installation is observed, e.g. IEC 60079-14.

TECHNICAL DATA	
Type	E1FU Tri-Star
Design Specification	BS 6121: Part 1: 1989, EN 50262:1999
ATEX Certification	SIRA06ATEX1097X
Code of Protection Category	ATEX II 2 GD / 3 GD Ex d IIC, Ex e II, Ex nR II, Ex tD A21 IP66, - Equipment Zone 1, Zone 2, Zone 21, & Zone 22 - Gas Groups IIA, IIB, IIC
Compliance Standards	EN 60079-0:2004, EN 60079-1:2004, EN 60079-7:2003, EN 60079-15:2003, EN 61241-0:2004, EN 61241-1:2004
IECEx Approval Number	IECEx SIR 06.0043X
Code of Protection Category	Ex d IIC, Ex e II, Ex nR II, Ex tD A21 IP66, Ex d I, Ex e I
Compliance Standards	IEC 60079-0:2004, IEC 60079-1:2003, IEC 60079-7:2001, IEC 60079-15:2005, IEC 61241-0:2004, IEC 61241-1:2004
GOST R Certificate Number	POCC GB. ГБ05.Б01912
Code of Protection Category	Ex d IIC U / Ex e II U
Gost Compliance Standards	ГОСТ P 52350.0-2005, ГОСТ P 52350.1-2005, ГОСТ P 52350.7-2005
GGTN Permit Number	PPC 00-18262
GOST K Certificate Number	KZ7500052.05.01.00063
RoK Permit for Use Number	08-067693
Continuous Operating Temperature	-60°C to +130°C
Ingress Protection Rating	IP66 as standard, IP67 / IP68 available on request. Deluge Proof when fitted with optional CMP O-ring in the cable gland body joint
Cable Gland Material	Brass, Electroless Nickel Plated Brass, Aluminium, Stainless Steel
Seal Material	CMP SOLO LSF Thermoplastic Elastomer
Cable Type	Single Wire Armour (SWA), Aluminium Wire Armour (AWA), Steel Tape Armour (STA), Wire Braid Armour, Aluminium Strip Armour (ASA), Pliable Wire Armour (PWA), Screened Flexible Wire Braid (e.g. CY / SY), Armoured & Jacketed
Armour Clamping	Reversible Armour Cone & AnyWay Universal Clamping Ring
Sealing Technique	CMP Inner Displacement Seal & Unique CMP "LRS"™ Outer Seal (Load Retention Seal)
Sealing Area(s)	Cable Inner Bedding & Cable Outer Sheath
Optional Accessories	Locknut, Shroud, Entry Thread Sealing Washer, Serrated Washer, Earth Tag, Adaptor/Reducer

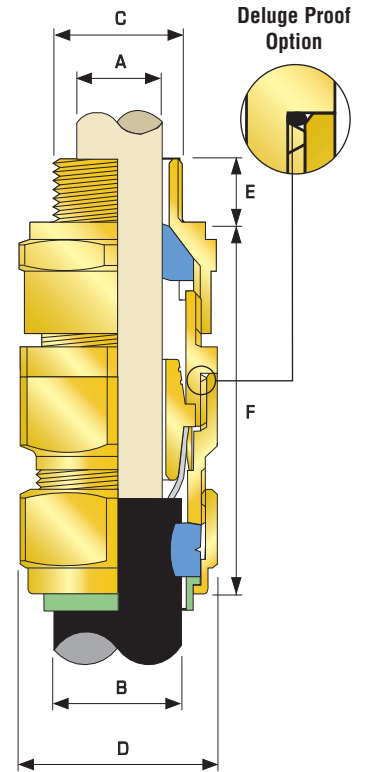

Note 1: Deluge Proof version available, ferrule colour coded "natural" for ease of identification.

Note 2: Stepped Cone is suitable for SWA cables, Grooved Cone is suitable for all other approved armoured cables

Note: Ingress Protection and Deluge Protection are essentially different and should not be confused with each other.

Cable Gland Selection Table

Cable Gland Size	Entry Threads 'C'			Minimum Thread Length 'E'	Cable Bedding Diameter 'A'		Overall Cable Diameter 'B'		Armour Range ¹				Across Flats 'D'	Across Corners 'D'	Nominal Protrusion Length 'F'	Ordering Reference (Brass Metric) #	PVC Shroud Reference*	Cable Gland Weight (Kgs)
	Standard		Option		Min	Max	Min	Max	Grooved Cone		Stepped Cone							
	Metric	NPT	NPT 2						Min	Max	Min	Max						
20S/16	M20	1/2"	3/4"	15.0	3.1	8.7	6.1	11.5	0	1.0	0.9	1.0	24.0	24.4	58.5	20S16E1FU1RA	PVC04	0.163
20S	M20	1/2"	3/4"	15.0	6.1	11.7	9.5	15.9	0	1.0	0.9	1.25	24.0	26.6	58.5	20SE1FU1RA	PVC04	0.163
20	M20	1/2"	3/4"	15.0	6.5	14.0	12.5	20.9	0	1.0	0.9	1.25	30.5	33.3	60.5	20E1FU1RA	PVC06	0.217
25S	M25	3/4"	1"	15.0	11.1	20.0	14.0	22.0	0	1.0	1.25	1.6	37.5	40.5	67.5	25SE1FU1RA	PVC09	0.345
25	M25	3/4"	1"	15.0	11.1	20.0	18.2	26.2	0	1.0	1.25	1.6	37.5	40.5	67.5	25E1FU1RA	PVC09	0.345
32	M32	1"	1-1/4"	15.0	17.0	26.3	23.7	33.9	0	1.0	1.6	2.0	46.0	51.0	69.5	32E1FU1RA	PVC11	0.484
40	M40	1-1/4"	1-1/2"	15.0	23.5	32.2	27.9	40.4	0	1.0	1.6	2.0	55.0	61.0	78.0	40E1FU1RA	PVC15	0.700
50S	M50	1-1/2"	2"	15.0	31.0	38.2	35.2	46.7	0	1.0	2.0	2.5	60.0	66.5	75.5	50SE1FU1RA	PVC18	0.800
50	M50	2"	2-1/2"	15.0	35.6	44.1	40.4	53.1	0	1.0	2.0	2.5	70.0	78.6	80.5	50E1FU1RA	PVC21	0.830
63S	M63	2"	2-1/2"	15.0	41.5	50.0	45.6	59.4	0	1.0	2.0	2.5	75.0	83.2	91.5	63SE1FU1RA	PVC23	1.415
63	M63	2-1/2"	3"	15.0	47.2	56.0	54.6	65.9	0	1.0	2.0	2.5	80.0	89.0	92.0	63E1FU1RA	PVC25	1.514
75S	M75	2-1/2"	3"	15.0	54.0	62.0	59.0	72.1	0	1.0	2.0	2.5	89.0	101.6	99.0	75SE1FU1RA	PVC28	2.199
75	M75	3"	3-1/2"	15.0	61.1	68.0	66.7	78.5	0	1.0	2.0	2.5	99.0	111.1	102.0	75E1FU1RA	PVC30	2.770
90	M90	3-1/2"	4"	15.0	66.6	80.0	76.2	90.4	0	1.6	3.15	3.15	114.0	128.6	120.0	90E1FU1RA	PVC32	4.350
100	M100	-	-	15.0	76.0	91.0	86.1	101.5	0	1.6	3.15	4.0	123.0	138.0	148.0	100E1FU1RA	150/50HST	4.750
115	M115	-	-	15.0	86.0	98.0	101.5	110.3	0	1.6	3.15	4.0	133.4	147.8	169.0	115E1FU1RA	180/60HST	7.300
130	M130	-	-	15.0	97.0	115.0	114.2	123.3	0	1.6	3.15	4.0	146.1	161.9	183.0	130E1FU1RA	180/60HST	8.600

All dimensions in millimetres

Note: *LSF Shrouds also available on request. Alternative armour clamping range available for non-standard armour sizes. Marine approvals including Lloyds, DNV & ABS are also available from CMP Products.
Other thread forms are available.

E2FU CABLE GLAND

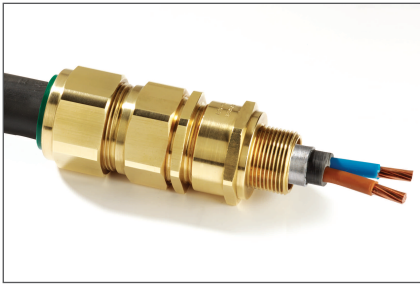

E2FU Tri-Star Flameproof Ex d, Increased Safety Ex e and Restricted Breathing Ex nR Cable Gland

CMP Type E2FU Tri-Star Triple Certified Flameproof (Type 'd'), Increased Safety (Type 'e') and Restricted Breathing (Type 'nR') indoor and outdoor cable gland for use in Zone 1, Zone 2, Zone 21 and Zone 22 Hazardous Areas with all types of Lead Covered or Lead Sheathed and armoured cable. This cable gland provides a Flameproof seal on the cable inner lead covering and in addition the gas tight seal has been tested to prove compatibility with Restricted Breathing equipment. The cable gland allows mechanical cable retention and earth continuity via the cable armour termination, and also earth bonding of the inner Lead Covering or Lead Sheath. Separate tightening actions for the inner Displacement Seal and the Armour Termination afford maximum control over the pressure applied to the cable inner lead covering, and also allows the effectiveness of the gas tight seal to be tested. A detachable universal armour cone and AnyWay clamping ring arrangement facilitates remote make off and enables the cable to be disconnected from the equipment. An environmental / load retention seal is provided on the cable outer sheath.

The CMP E2FU Tri-Star Cable Gland is suitable for use with all forms of equipment protection permitted in Zone 1, Zone 2, Zone 21 & Zone 22 provided always that the prevailing code of practice for selection and installation is observed, e.g. IEC 60079-14.

TECHNICAL DATA	
Type	E2FU Tri-Star
Design Specification	BS 6121: Part 1: 1989, EN 50262:1999
ATEX Certification	SIRA06ATEX1097X
Code of Protection Category	ATEX (Ex) II 2 GD / 3 GD Ex d IIC, Ex e II, Ex nR II, Ex tD A21 IP66, - Equipment Zone 1, Zone 2, Zone 21, & Zone 22 - Gas Groups IIA, IIB, IIC
Compliance Standards	EN 60079-0: 2004, EN 60079-1:2004, EN 60079-7:2003, EN 60079-15:2003, EN 61241-0:2004, EN 61241-1:2004
IECEx Approval Number	IECEx SIR 06.0043X
Code of Protection Category	Ex d IIC, Ex e II, Ex nR II, Ex tD A21 IP66, Ex d I, Ex e I
Compliance Standards	IEC 60079-0:2004, IEC 60079-1:2003, IEC 60079-7:2003, IEC 60079-15:2005, IEC61241-0:2004, IEC 61241-1:2004
GOST R Certificate Number	POCC GB. ГЕ05.В01912
Code of Protection Category	Ex d IIC U / Ex e II U
Gost Compliance Standards	ГОСТ P 52350.0-2005,ГОСТ P 52350.1-2005,ГОСТ P 52350.7-2005
GGTN Permit Number	PPC 00-18262
GOST K Certificate Number	KZ7500052.05.01.00063
RoK Permit for Use Number	08-067693
INMETRO / UC Approval	MC, AEX-7618-X
Code of Protection Category	BR-Ex d IIC / BR-Ex e II
Compliance Standards	IEC 60079-0/00, IEC 60079-1/01, IEC 60079-7/01, NBR IEC 60529/05
Continuous Operating Temperature	-60°C to +130°C
Ingress Protection Rating	IP66 as standard, IP67 / IP68 available on request. Deluge Proof when fitted with optional CMP O-ring in the cable gland body joint
Cable Gland Material	Brass, Electroless Nickel Plated Brass, Aluminium, Stainless Steel
Seal Material	CMP SOLO LSF Thermoplastic Elastomer
Cable Type	Lead Sheathed and Single Wire Armour (SWA), Aluminium Wire Armour (AWA), Steel Tape Armour (STA), Wire Braid Armour, Aluminium Strip Armour (ASA), Pliable Wire Armour (PWA)
Armour Clamping	Reversible Armour Cone & AnyWay Universal Clamping Ring
Sealing Technique	CMP Inner Displacement Seal & Unique CMP "LRS"™ Outer Seal (Load Retention Seal)
Sealing Area(s)	Cable Inner Lead Covering & Cable Outer Sheath
Optional Accessories	Locknut, Shroud, Entry Thread Sealing Washer, Serrated Washer, Earth Tag, Adaptor/Reducer

Note: Ingress Protection and Deluge Protection are essentially different and should not be confused with each other.

Cable Gland Selection Table

Cable Gland Size	Entry Threads 'C'			Minimum Thread Length 'E'	Lead Sheath Diameter 'A'		Overall Cable Diameter 'B'		Armour Range [†]				Across Flats 'D'	Across Corners 'D'	Nominal Protrusion Length 'F'	Ordering Reference (Brass Metric) #	PVC Shroud Reference*	Cable Gland Weight Kgs
	Standard		Option		Min	Max	Min	Max	Grooved Cone		Stepped Cone							
	Metric	NPT	NPT 2						Min	Max	Min	Max						
20S/16	M20	1/2"	3/4"	15.0	3.1	8.7	6.1	11.5	0.0	1.0	0.9	1.0	24.0	24.4	58.5	20S16E2FU1RA	PVC04	0.163
20S	M20	1/2"	3/4"	15.0	6.1	11.7	9.5	15.9	0.0	1.0	0.9	1.25	24.0	26.6	58.5	20SE2FU1RA	PVC04	0.163
20	M20	1/2"	3/4"	15.0	6.5	14.0	12.5	20.9	0.0	1.0	0.9	1.25	30.5	33.3	60.5	20E2FU1RA	PVC06	0.217
25S	M25	3/4"	1"	15.0	11.1	20.0	14.0	22.0	0.0	1.0	1.25	1.6	37.5	40.5	67.5	25SE2FU1RA	PVC09	0.345
25	M25	3/4"	1"	15.0	11.1	20.0	18.2	26.2	0.0	1.0	1.25	1.6	37.5	40.5	67.5	25E2FU1RA	PVC09	0.345
32	M32	1"	1-1/4"	15.0	17.0	26.3	23.7	33.9	0.0	1.0	1.6	2.0	46.0	51.0	69.5	32E2FU1RA	PVC11	0.484
40	M40	1-1/4"	1-1/2"	15.0	23.5	32.2	27.9	40.4	0.0	1.0	1.6	2.0	55.0	61.0	78.0	40E2FU1RA	PVC15	0.700
50S	M50	1-1/2"	2"	15.0	31.0	38.2	35.2	46.7	0.0	1.0	2.0	2.5	60.0	66.5	75.5	50SE2FU1RA	PVC18	0.800
50	M50	2"	2-1/2"	15.0	35.6	44.1	40.4	53.1	0.0	1.0	2.0	2.5	70.0	78.6	80.5	50E2FU1RA	PVC21	0.830
63S	M63	2"	2-1/2"	15.0	41.5	50.0	45.6	59.4	0.0	1.0	2.0	2.5	75.0	83.2	91.5	63SE2FU1RA	PVC23	1.415
63	M63	2-1/2"	3"	15.0	47.2	56.0	54.6	65.9	0.0	1.0	2.0	2.5	80.0	89.0	92.0	63E2FU1RA	PVC25	1.514
75S	M75	2-1/2"	3"	15.0	54.0	62.0	59.0	72.1	0.0	1.0	2.0	2.5	89.0	101.6	99.0	75SE2FU1RA	PVC28	2.199
75	M75	3"	3-1/2"	15.0	61.1	68.0	66.7	78.5	0.0	1.0	2.0	2.5	99.0	111.1	102.0	75E2FU1RA	PVC30	2.770
90	M90	3-1/2"	4"	15.0	66.6	80.0	76.2	90.4	0.0	1.6	3.15	3.15	114.0	128.6	120.0	90E2FU1RA	PVC32	4.350
100	M100	-	-	15.0	76.0	91.0	86.1	101.5	0.0	1.6	3.15	4.0	123.0	138.0	148.0	100E2FU1RA	150/50HST	4.750
115	M115	-	-	15.0	86.0	98.0	101.5	110.3	0.0	1.6	3.15	4.0	133.4	147.8	169.0	115E2FU1RA	180/60HST	7.300
130	M130	-	-	15.0	97.0	115.0	114.2	123.3	0.0	1.6	3.15	4.0	146.1	161.9	183.0	130E2FU1RA	180/60HST	8.600

All dimensions in millimetres

Note: *LSF Shrouds also available on request. Alternative armour clamping range available for non-standard armour sizes. Marine approvals including Lloyds, DNV & ABS are also available from CMP Products. # Other thread forms are available.

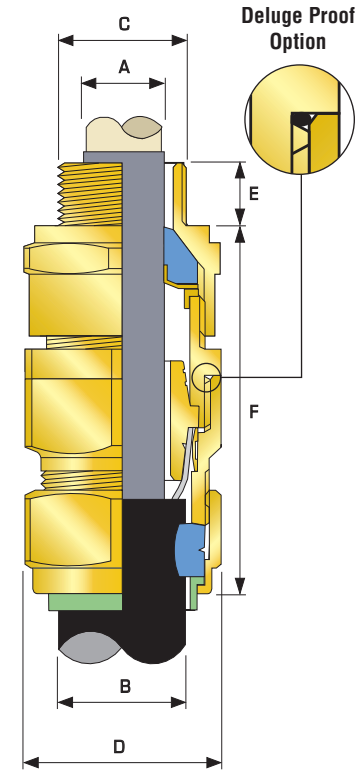

Note 1: Deluge Proof version available, ferrule colour coded "natural" for ease of identification.

Note 2: Stepped Cone is suitable for SWA cables, Grooved Cone is suitable for all other approved armoured cables

E1FW CABLE GLAND

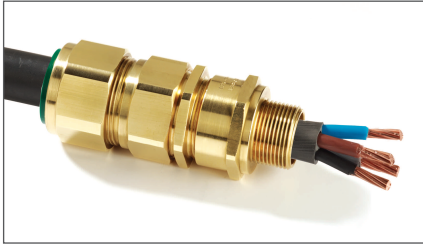

E1FW Tri-Star Flameproof Ex d, Increased Safety Ex e and Restricted Breathing Ex nR Cable Gland

CMP Type E1FW Tri-Star Triple Certified Flameproof (Type 'd'), Increased Safety (Type 'e') and Restricted Breathing (Type 'nR') cable gland for use in Zone 1, Zone 2, Zone 21 and Zone 22 Hazardous Areas with Single Wire Armour (SWA) cable. This cable gland provides a Flameproof seal on the cable inner bedding and in addition the gas tight seal has been tested to prove compatibility with Restricted Breathing equipment. The cable gland allows mechanical cable retention and earth continuity via the cable armour termination. Separate tightening actions for the inner displacement seal and the armour termination afford maximum control over the pressure applied to the cable bedding, and also allows the effectiveness of the gas tight seal to be tested. A detachable armour cone and AnyWay clamping ring arrangement facilitates remote make off and enables the cable to be disconnected from the equipment. An environmental / load retention seal is provided on the cable outer sheath.

The CMP E1FW Tri-Star Cable Gland is suitable for use with all forms of equipment protection permitted in Zone 1, Zone 2, Zone 21 & Zone 22 provided always that the prevailing code of practice for selection and installation is observed, e.g. IEC 60079-14.

TECHNICAL DATA	
Type	E1FW Tri-Star
Design Specification	BS 6121: Part 1: 1989, EN 50262:1999
ATEX Certification	SIRA06ATEX1097X
Code of Protection Category	ATEX II 2GD / 3GD Ex d IIC, Ex e II, Ex nR II, Ex tD A21 IP66, - Equipment Zone 1, Zone 2, Zone 21, & Zone 22 - Gas Groups IIA, IIB, IIC, ATEX IM2 Exd I / Exe I
Compliance Standards	EN 60079-0:2004, EN 60079-1:2004, EN 60079-7: 2003, EN 60079-15:2003, EN 61241-0:2004, EN 61241-1:2004
IECEx Approval Number	IECEx SIR 06.0043X
Code of Protection Category	Ex d IIC, Ex e II, Ex nR II, Ex tD A21 IP66, Ex d I, Ex e I
Compliance Standards	IEC 60079-0:2004, IEC 60079-1:2003, IEC 60079-7:2001, IEC 60079-15:2005, IEC 61241-0:2004, IEC 61241-1:2004
GOST R Certificate Number	POCC GB.ГБ05.В01912
Code of Protection Category	Ex d IIC U / Ex e II U
GOST Compliance Standards	ГОСТ Р 52350.0-2005, ГОСТ Р 52350.1-2005, ГОСТ Р 52350.7-2005
GGTN Permit Number	PPC 00-18262
GOST K Certificate Number	KZ7500052.05.01.00063
RoK Permit for Use Number	08-067693
INMETRO / UC Approval	MC, AEX-7618-X
Code of Protection Category	BR-Ex d IIC / BR-Ex e II / IP66W
Compliance Standards	IEC 60079-0/00, IEC 60079-1/01, IEC 60079-7/01, & NBR IEC 60529/05
Continuous Operating Temperature	-60°C to +130°C
Ingress Protection Rating	IP66 as standard, IP67 / IP68 available on request. Deluge Proof when fitted with optional CMP O-ring in the cable gland body joint
Cable Gland Material	Brass, Electroless Nickel Plated Brass, Stainless Steel, Aluminium
Seal Material	CMP SOLO LSF Thermoplastic Elastomer
Cable Type	Single Wire Armour (SWA)
Armour Clamping	Detachable Armour Cone & AnyWay Universal Clamping Ring
Sealing Technique	CMP Inner Displacement Seal & Unique CMP "LRS" [™] Outer Seal (Load Retention Seal)
Sealing Area(s)	Cable Inner Bedding & Cable Outer Sheath
Optional Accessories	Locknut, Shroud, Entry Thread Sealing Washer, Serrated Washer, Earth Tag, Adaptor/Reducer

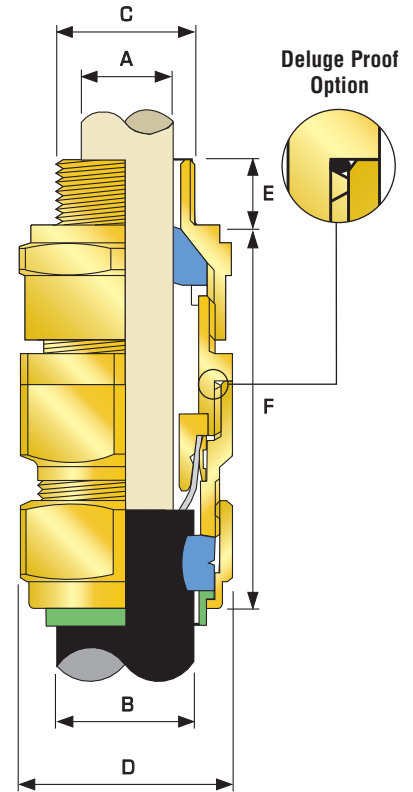

Note: Ingress Protection and Deluge Protection are essentially different and should not be confused with each other.

Note: Deluge Proof version available, ferrule colour coded "natural" for ease of identification

Cable Gland Selection Table

Cable Gland Size	Available Entry Threads 'C'			Minimum Thread Length 'E'	Cable Bedding Diameter 'A'		Overall Cable Diameter 'B'		Armour Range †		Across Flats 'D'	Across Corners 'D'	Nominal Protusion Length 'F'	Ordering Reference (Brass Metric) #	PVC Shroud Reference*	Cable Gland Weight (Kgs)
	Standard		Option		Min	Max	Min	Max	Min	Max						
	Metric	NPT	NPT 2													
20S/16	M20	1/2"	3/4"	15.0	3.1	8.7	6.1	11.5	0.90	1.00	24.0	24.4	58.5	20S16E1FW1RA	PVC04	0.157
20S	M20	1/2"	3/4"	15.0	6.1	11.7	9.5	15.9	0.90	1.25	24.0	26.6	58.5	20SE1FW1RA	PVC04	0.157
20	M20	1/2"	3/4"	15.0	6.5	14.0	12.5	20.9	0.90	1.25	30.5	33.3	60.5	20E1FW1RA	PVC06	0.206
25S	M25	3/4"	1"	15.0	11.1	20.0	14.0	22.0	1.25	1.60	37.5	40.5	67.5	25SE1FW1RA	PVC09	0.325
25	M25	3/4"	1"	15.0	11.1	20.0	18.2	26.2	1.25	1.60	37.5	40.5	67.5	25E1FW1RA	PVC09	0.325
32	M32	1"	1-1/4"	15.0	17.0	26.3	23.7	33.9	1.60	2.00	46.0	51.0	69.5	32E1FW1RA	PVC11	0.452
40	M40	1-1/4"	1-1/2"	15.0	22.0	32.2	27.9	40.4	1.60	2.00	55.0	61.0	78.0	40E1FW1RA	PVC15	0.657
50S	M50	1-1/2"	2"	15.0	29.5	38.2	35.2	46.7	2.00	2.50	60.0	66.5	75.5	50SE1FW1RA	PVC18	0.734
50	M50	2"	2-1/2"	15.0	35.6	44.1	40.4	53.1	2.00	2.50	70.0	78.6	80.5	50E1FW1RA	PVC21	0.748
63S	M63	2"	2-1/2"	15.0	40.1	50.0	45.6	59.4	2.00	2.50	75.0	83.2	91.5	63SE1FW1RA	PVC23	1.337
63	M63	2-1/2"	3"	15.0	47.2	56.0	54.6	65.9	2.00	2.50	80.0	89.0	92.0	63E1FW1RA	PVC25	1.436
75S	M75	2-1/2"	3"	15.0	52.8	62.0	59.0	72.1	2.00	2.50	89.0	101.6	99.0	75SE1FW1RA	PVC28	2.073
75	M75	3"	3-1/2"	15.0	59.1	68.0	66.7	78.5	2.00	2.50	99.0	111.1	102.0	75E1FW1RA	PVC30	2.622
90	M90	3-1/2"	4"	15.0	66.6	80.0	76.2	90.4	3.15	3.15	114.0	128.6	120.0	90E1FW1RA	PVC32	4.174
100	M100	-	-	15.0	76.0	91.0	86.1	101.5	3.15	4.00	123.0	138.0	148.0	100E1FW1RA	150/50HST	4.523
115	M115	-	-	15.0	86.0	98.0	101.5	110.3	3.15	4.00	133.4	147.8	169.0	115E1FW1RA	180/60HST	6.860
130	M130	-	-	15.0	97.0	115.0	114.2	123.3	3.15	4.00	146.1	161.9	183.0	130E1FW1RA	180/60HST	8.121

All dimensions in millimetres

Note: *LSF Shrouds also available on request. Alternative armour clamping range available for non-standard armour sizes. Marine approvals including Lloyds, DNV & ABS are also available from CMP Products. # Other thread forms are available.

E2FW CABLE GLAND

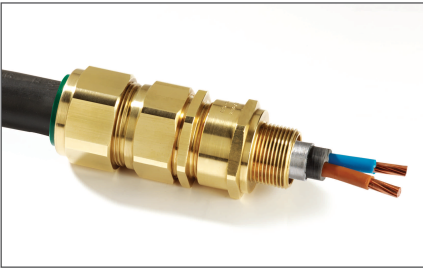

E2FW Tri-Star Flameproof Ex d, Increased Safety Ex e and Restricted Breathing Ex nR Cable Gland

CMP Type E2FW Tri-Star Triple Certified Flameproof (Type 'd'), Increased Safety (Type 'e') and Restricted Breathing (Type 'nR') cable gland with use in Zone 1, Zone 2, Zone 21 and Zone 22 Hazardous Areas with lead covered or lead sheathed and single wire armour (SWA) cable. This cable gland provides a flameproof seal on the cable inner lead covering and in addition the gas tight seal has been tested to prove compatibility with Restricted Breathing equipment that relies upon flammable gases being excluded from the main enclosure. The cable gland allows mechanical cable retention and earth continuity via the cable armour termination, and also earth bonding of the inner lead covering or lead sheath. Separate tightening actions for the inner displacement seal and the armour termination afford maximum control over the pressure applied to the cable inner lead covering, and also allows the effectiveness of the gas tight seal to be tested. A detachable armour cone and AnyWay clamping ring arrangement facilitates remote make off and enables the cable to be disconnected from the equipment. An environmental / load retention seal is provided on the cable outer sheath.

The CMP E2FW Tri-Star Cable Gland is suitable for use with all forms of equipment protection permitted in Zone 1, Zone 2, Zone 21 & Zone 22 provided always that the prevailing code of practice for selection and installation is observed, e.g. IEC 60079-14.

TECHNICAL DATA	
Type	E2FW Tri-Star
Design Specification	BS 6121: Part 1: 1989, EN 50262:1999
ATEX Certification	SIRA06ATEX1097X
Code of Protection Category	ATEX (Ex) II 2GD / 3 GD Ex d IIC, Ex e II, Ex nR II, Ex tD A21 IP66, - Equipment Zone 1, Zone 2, Zone 21, & Zone 22 - Gas Groups IIA, IIB, IIC
Compliance Standards	EN 60079-0: 2004, EN 60079-1:2004, EN 60079-7: 2003, EN 60079-15:2003, EN 61241-0:2004, EN 61241-1:2004
IECEx Approval Number	IECEx SIR 06.0043X
Code of Protection Category	Ex d IIC / Ex e II / Ex nR II / Ex tD A21 IP66, Ex d I / Ex e I
Compliance Standards	IEC 60079-0:2004, IEC 60079-1:2003, IEC 60079-7:2001, IEC 60079-15:2005, IEC 61241-0:2004, IEC 61241-1:2004
GOST R Certificate Number	POCC GB.ГБ05.В01912
Code of Protection Category	Ex d IIC U / Ex e II U
GOST Compliance Standards	ГОСТ P 52350.0-2005,ГОСТ P 52350.1-2005,ГОСТ P 52350.7-2005
GGTN Permit Number	PPC 00-18262
GOST K Certificate Number	KZ7500052.05.01.00063
RoK Permit for Use Number	08-067693
INMETRO / UC Approval	MC, AEX-7618-X
Code of Protection Category	BR-Ex d IIC / BR-Ex e II / IP66W
Compliance Standards	IEC 60079-0/00, IEC 60079-1/01, IEC 60079-7/01, & NBR IEC 60529/05
Continuous Operating Temperature	-60°C to +130°C
Ingress Protection Rating	IP66 as standard, IP67 / IP68 available on request. Deluge Proof when fitted with optional CMP O-ring in the cable gland body joint
Cable Gland Material	Brass, Electroless Nickel Plated Brass, Stainless Steel, Aluminium
Seal Material	CMP SOLO LSF Thermoplastic Elastomer
Cable Type	Lead Sheathed and Single Wire Armour (SWA)
Armour Clamping	Detachable Armour Cone & AnyWay Universal Clamping Ring
Sealing Technique	CMP Inner Displacement Seal & Unique CMP "LRS" [™] Outer Seal (Load Retention Seal)
Sealing Area(s)	Cable Inner Lead Covering & Cable Outer Sheath
Optional Accessories	Locknut, Shroud, Entry Thread Sealing Washer, Serrated Washer, Earth Tag, Adaptor/Reducer

Note: Ingress Protection and Deluge Protection are essentially different and should not be confused with each other.

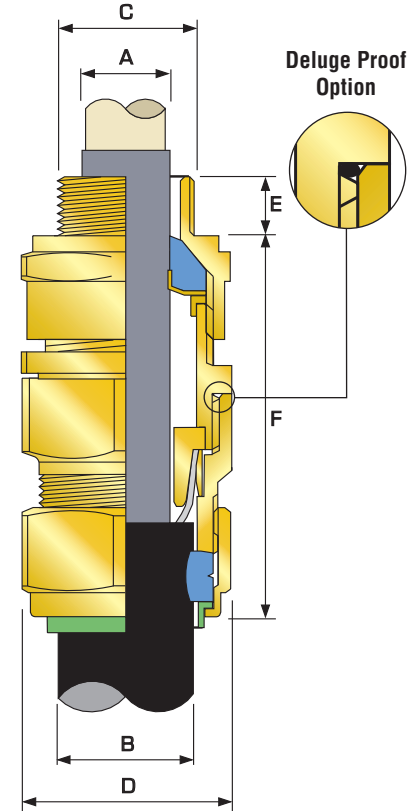

Note: Deluge Proof version available, ferrule colour coded "natural" for ease of identification

Cable Gland Selection Table

Cable Gland Size	Available Entry Threads 'C'			Minimum Thread Length 'E'	Cable Lead Sheath Diameter 'A'		Overall Cable Diameter 'B'		Armour Range †		Across Flats 'D'	Across Corners 'D'	Nominal Protrusion Length 'F'	Ordering Reference (Brass Metric) #	PVC Shroud Reference*	Cable Gland Weight (Kgs)
	Standard		Option		Min	Max	Min	Max	Min	Max						
	Metric	NPT	NPT													
20S/16	M20	1/2"	3/4"	15.0	3.1	8.7	6.1	11.5	0.90	1.00	24.0	24.4	58.5	20S16E2FW1RA	PVC04	0.157
20S	M20	1/2"	3/4"	15.0	6.1	11.7	9.5	15.9	0.90	1.25	24.0	26.6	58.5	20SE2FW1RA	PVC04	0.157
20	M20	1/2"	3/4"	15.0	6.5	14.0	12.5	20.9	0.90	1.25	30.5	33.3	60.5	20E2FW1RA	PVC06	0.206
25S	M25	3/4"	1"	15.0	11.1	20.0	14.0	22.0	1.25	1.60	37.5	40.5	67.5	25SE2FW1RA	PVC09	0.325
25	M25	3/4"	1"	15.0	11.1	20.0	18.2	26.2	1.25	1.60	37.5	40.5	67.5	25E2FW1RA	PVC09	0.325
32	M32	1"	1-1/4"	15.0	17.0	26.3	23.7	33.9	1.60	2.00	46.0	51.0	69.5	32E2FW1RA	PVC11	0.452
40	M40	1-1/4"	1-1/2"	15.0	22.0	32.2	27.9	40.4	1.60	2.00	55.0	61.0	78.0	40E2FW1RA	PVC15	0.657
50S	M50	1-1/2"	2"	15.0	29.5	38.2	35.2	46.7	2.00	2.50	60.0	66.5	75.5	50SE2FW1RA	PVC18	0.734
50	M50	2"	2-1/2"	15.0	35.6	44.1	40.4	53.1	2.00	2.50	70.0	78.6	80.5	50E2FW1RA	PVC21	0.748
63S	M63	2"	2-1/2"	15.0	40.1	50.0	45.6	59.4	2.00	2.50	75.0	83.2	91.5	63SE2FW1RA	PVC23	1.337
63	M63	2-1/2"	3"	15.0	47.2	56.0	54.6	65.9	2.00	2.50	80.0	89.0	92.0	63E2FW1RA	PVC25	1.436
75S	M75	2-1/2"	3"	15.0	52.8	62.0	59.0	72.1	2.00	2.50	89.0	101.6	99.0	75SE2FW1RA	PVC28	2.073
75	M75	3"	3-1/2"	15.0	59.1	68.0	66.7	78.5	2.00	2.50	99.0	111.1	102.0	75E2FW1RA	PVC30	2.622
90	M90	3-1/2"	4"	15.0	66.6	80.0	76.2	90.4	3.15	3.15	114.0	128.6	120.0	90E2FW1RA	PVC32	4.174
100	M100	-	-	15.0	76.0	91.0	86.1	101.5	3.15	4.00	123.0	138.0	148.0	100E2FW1RA	150/50HST	4.523
115	M115	-	-	15.0	86.0	98.0	101.5	110.3	3.15	4.00	133.4	147.8	169.0	115E2FW1RA	180/60HST	6.860
130	M130	-	-	15.0	97.0	115.0	114.2	123.3	3.15	4.00	146.1	161.9	183.0	130E2FW1RA	180/60HST	8.121

All dimensions in millimetres

Note: Alternative armour clamping range available for non-standard armour sizes. Marine approvals including Lloyds, DNV & ABS are also available from CMP Products.
Other thread forms are available



E1FX CABLE GLAND

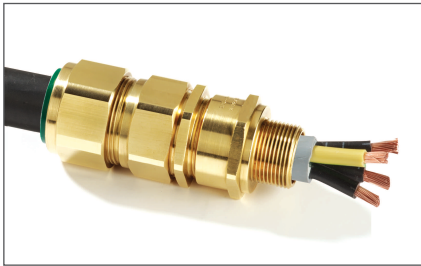

E1FX Tri-Star Flameproof Ex d, Increased Safety Ex e and Restricted Breathing Ex nR Cable Gland

CMP Type E1FX Tri-Star Triple Certified Flameproof (Type 'd'), Increased Safety (Type 'e') and Restricted Breathing (Type 'nR') indoor and outdoor cable gland for use in Zone 1, Zone 2, Zone 21 and Zone 22 Hazardous Areas with Braided, Pliable Wire Armour (PWA), Strip Armour and Steel Tape Armour (STA) cable. This cable gland provides a Flameproof seal on the cable inner bedding and in addition the gas tight seal has been tested to prove compatibility with Restricted Breathing equipment. The cable gland allows mechanical cable retention and earth continuity via the cable armour termination. Separate tightening actions for the inner displacement seal and the armour termination afford maximum control over the pressure applied to cable bedding, and also allows the effectiveness of the gas tight seal to be tested. A detachable armour cone and AnyWay clamping ring arrangement facilitates remote make off and enables the cable to be disconnected from the equipment. An environmental / load retention seal is provided on the cable outer sheath.

The CMP E1FX Tri-Star Cable Gland is suitable for use with all forms of equipment protection permitted in Zone 1, Zone 2, Zone 21 & Zone 22 provided always that the prevailing code of practice for selection and installation is observed, e.g. IEC 60079-14.

TECHNICAL DATA

Type	E1FX Tri-Star
Design Specification	BS 6121: Part 1: 1989, EN 50262:1999
ATEX Certification	SIRA06ATEX1097X
Code of Protection Category	ATEX II 2GD / 3GD Ex d IIC, Ex e II, Ex nR II Ex tD A21 IP66, - Equipment Zone 1, Zone 2, Zone 21, & Zone 22 - Gas Groups IIA, IIB, IIC, IM2, Ex d I / Ex e I
Compliance Standards	EN 60079-0: 2004, EN 60079-1:2004, EN 60079-7: 2003, EN 60079-15:2003, EN 61241-0:2004, EN 61241-1:2004
IECEX Approval Number	IECEX SIR 06.0043X
Code of Protection Category	Ex d IIC, Ex e II, Ex nR II, Ex tD A21 IP66, Ex d I, Ex e I
Compliance Standards	IEC 60079-0:2004, IEC 60079-1:2003, IEC 60079-7:2001, IEC 60079-15:2005, IEC61241-0:2004, IEC 61241-1:2004
GOST R Certificate Number	POCC GB. ГБ05.Б01912
Code of Protection Category	Ex d IIC U / EX e II U
Compliance Standards	ГОСТ P 52350.0-2005, ГОСТ P 52350.1-2005, ГОСТ P 52350.7-2005
GGTN Permit Number	PPC 00-18262
GOST K Certificate Number	KZ7500052.05.01.00063
RoK Permit for Use Number	08-067693
INMETRO / UC Approval	MC, AEX-7618-X
Code of Protection Category	BR-Ex d IIC / BR-Ex e II / IP66W
Compliance Standards	IEC 60079-0/00, IEC 60079-1/01, IEC 60079-7/01, & NBR IEC 60529/05
Continuous Operating Temperature	-60°C to +130°C
Ingress Protection Rating	IP66 as standard, IP67 / IP68 available on request. Deluge Proof when fitted with optional CMP O-ring in the cable gland body joint
Cable Gland Material	Brass, Electroless Nickel Plated Brass, Stainless Steel, Aluminium
Seal Material	CMP SOLO LSF Thermoplastic Elastomer
Cable Type	Wire Braid Armour, Screened Flexible Wire Braid (e.g. CY / SY), Pliable Wire Armour PWA, Steel Tape Armour (STA), Aluminium Strip Armour (ASA), Armored & Jacketed.
Armour Clamping	Detachable Armour Cone & AnyWay Universal Clamping Ring
Sealing Technique	CMP Inner Displacement Seal & Unique CMP "LRS"™ Outer Seal (Load Retention Seal)
Sealing Area(s)	Cable Inner Bedding & Cable Outer Sheath
Optional Accessories	Locknut, Shroud, Entry Thread Sealing Washer, Serrated Washer, Earth Tag, Adaptor/Reducer

Note: Ingress Protection and Deluge Protection are essentially different and should not be confused with each other.

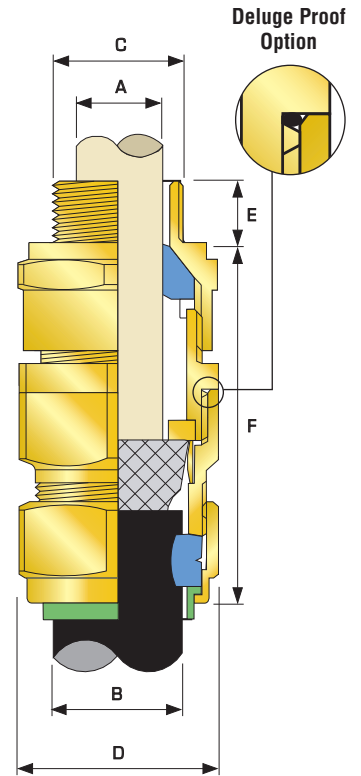

Note: Deluge Proof version available, ferrule colour coded "natural" for ease of identification

Cable Gland Selection Table

Cable Gland Size	Available Entry Threads 'C'			Minimum Thread Length 'E'	Cable Bedding Diameter 'A'		Overall Cable Diameter 'B'		Armour Range		Across Flats 'D'	Across Corners 'D'	Nominal Protrusion Length 'F'	Ordering Reference (Brass Metric) #	PVC Shroud Reference*	Cable Gland Weight (Kgs)
	Standard	Option			Min	Max	Min	Max	Min	Max						
		Metric	NPT													
20S/16	M20	1/2"	3/4"	15.0	3.1	8.7	6.1	11.5	0.0	1.0	24.0	24.4	58.5	20S16E1FX1RA	PVC04	0.158
20S	M20	1/2"	3/4"	15.0	6.1	11.7	9.5	15.9	0.0	1.0	24.0	26.6	58.5	20SE1FX1RA	PVC04	0.158
20	M20	1/2"	3/4"	15.0	6.5	14.0	12.5	20.9	0.0	1.0	30.5	33.3	60.5	20E1FX1RA	PVC06	0.208
25S	M25	3/4"	1"	15.0	11.1	20.0	14.0	22.0	0.0	1.0	37.5	40.5	67.5	25SE1FX1RA	PVC09	0.330
25	M25	3/4"	1"	15.0	11.1	20.0	18.2	26.2	0.0	1.0	37.5	40.5	67.5	25E1FX1RA	PVC09	0.330
32	M32	1"	1-1/4"	15.0	17.0	26.3	23.7	33.9	0.0	1.0	46.0	51.0	69.5	32E1FX1RA	PVC11	0.463
40	M40	1-1/4"	1-1/2"	15.0	22.0	32.2	27.9	40.4	0.0	1.0	55.0	61.0	78.0	40E1FX1RA	PVC15	0.671
50S	M50	1-1/2"	2"	15.0	29.5	38.2	35.2	46.7	0.0	1.0	60.0	66.5	75.5	50SE1FX1RA	PVC18	0.760
50	M50	2"	2-1/2"	15.0	35.6	44.1	40.4	53.1	0.0	1.0	70.0	78.6	80.5	50E1FX1RA	PVC21	0.777
63S	M63	2"	2-1/2"	15.0	40.1	50.0	45.6	59.4	0.0	1.0	75.0	83.2	91.5	63SE1FX1RA	PVC23	1.369
63	M63	2-1/2"	3"	15.0	47.2	56.0	54.6	65.9	0.0	1.0	80.0	89.0	92.0	63E1FX1RA	PVC25	1.472
75S	M75	2-1/2"	3"	15.0	52.8	62.0	59.0	72.1	0.0	1.0	89.0	101.6	99.0	75SE1FX1RA	PVC28	2.119
75	M75	3"	3-1/2"	15.0	59.1	68.0	66.7	78.5	0.0	1.0	99.0	111.1	102.0	75E1FX1RA	PVC30	2.688
90	M90	3-1/2"	4"	15.0	66.6	80.0	76.2	90.4	0.0	1.6	114.0	128.6	120.0	90E1FX1RA	PVC32	4.281
100	M100	-	-	15.0	76.0	91.0	86.1	101.5	0.0	1.6	123.0	138.0	148.0	100E1FX1RA	150/50HST	4.674
115	M115	-	-	15.0	86.0	98.0	101.5	110.3	0.0	1.6	133.4	147.8	169.0	115E1FX1RA	180/60HST	7.085
130	M130	-	-	15.0	97.0	115.0	114.2	123.3	0.0	1.6	146.1	161.9	183.0	130E1FX1RA	180/60HST	8.382

All dimensions in millimetres

Note: *LSF Shrouds also available on request. Alternative armour clamping range available for non-standard armour sizes. Marine approvals including Lloyds, DNV & ABS are also available from CMP Products. # Other thread forms are available

E2FX CABLE GLAND

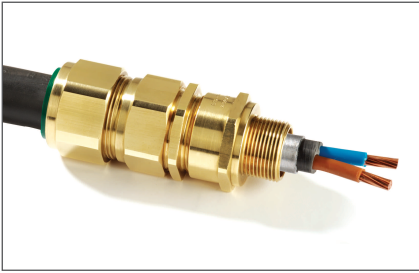

E2FX Tri-Star Flameproof Ex d, Increased Safety Ex e and Restricted Breathing Ex nR Cable Gland

CMP Type E2FX Tri-Star Triple Certified Flameproof (Type 'd'), Increased Safety (Type 'e') and Restricted Breathing (Type 'nR') cable gland for use in Zone 1, Zone 2, Zone 21 and Zone 22 Hazardous Areas with Lead Covered or Lead Sheathed and Braided, Pliable Wire Armour (PWA), Strip Armour, or Steel Tape Armour (STA) cable. This cable gland provides a Flameproof seal on the cable inner lead covering and in addition the gas tight seal has been tested to prove compatibility with restricted breathing equipment. The cable gland allows mechanical cable retention and earth continuity via the cable armour termination, and also earth bonding of the inner lead covering or lead sheath. Separate tightening actions for the inner displacement seal and the armour termination afford maximum control over the pressure applied to cable inner lead covering, and also allows the effectiveness of the gas tight seal to be tested. A detachable armour cone and AnyWay clamping ring arrangement facilitates remote make off and enables the cable to be disconnected from the equipment. An environmental / load retention seal is provided on the cable outer sheath.

The CMP E2FX Tri-Star Cable Gland is suitable for use with all forms of equipment protection permitted in Zone 1, Zone 2, Zone 21 & Zone 22 provided always that the prevailing code of practice for selection and installation is observed, e.g. IEC 60079-14.

TECHNICAL DATA	
Type	E2FX Tri-Star
Design Specification	BS 6121: Part 1: 1989, EN 50262:1999
ATEX Certification	SIRA06ATEX1097X
Code of Protection Category	ATEX Ⓜ II 2GD / 3GD Ex d IIC, Ex e II, Ex nR II, Ex tD A21 IP66, - Equipment Zone 1, Zone 2, Zone 21, & Zone 22 - Gas Groups IIA, IIB, IIC
Compliance Standards	EN 60079-0:2004, EN 60079-1:2004, EN 60079-7: 2003, EN 60079-15:2003, EN 61241-0:2004, EN 61241-1:2004
IECEx Approval Number	IECEx SIR 06.0043X
Code of Protection Category	Ex d IIC, Ex e II, Ex nR II, Ex tD A21 IP66
Compliance Standards	IEC 60079-0:2004, IEC 60079-1:2003, IEC 60079-7:2001, IEC 60079-15:2005, IEC61241-0:2004, IEC 61241-1:2004
GOST R Certificate Number	POCC GB.ГБ05.Б01912
Code of Protection Category	Ex d IIC U / EX e II U
Compliance Standards	ГОСТ P 52350.0-2005,ГОСТ P 52350.1-2005,ГОСТ P 52350.7-2005
GGTN Permit Number	PPC 00-18262
GOST K Certificate Number	KZ7500052.05.01.00063
RoK Permit for Use Number	08-067693
INMETRO / UC Approval	MC, AEX-7618-X
Code of Protection Category	BR-Ex d IIC / BR-Ex e II / IP66W
Compliance Standards	IEC 60079-0/00, IEC 60079-1/01, IEC 60079-7/01, & NBR IEC 60529/05
Continuous Operating Temperature	-60°C to +130°C
Ingress Protection Rating	IP66 as standard, IP67 / IP68 available on request. Deluge Proof when fitted with optional CMP O-ring in the cable gland body joint
Cable Gland Material	Brass, Electroless Nickel Plated Brass, Stainless Steel, Aluminium
Seal Material	CMP SOLO LSF Thermoplastic Elastomer
Cable Type	Lead Sheathed and Wire Braid Armour, Pliable Wire Armour (PWA), Steel Tape Armour (STA), Aluminium Strip Armour (ASA)
Armour Clamping	Detachable Armour Cone & AnyWay Universal Clamping Ring
Sealing Technique	CMP Inner Displacement Seal & Unique CMP "LRS"™ Outer Seal (Load Retention Seal)
Sealing Area(s)	Cable Inner Lead Sheath & Outer Cable Sheath
Optional Accessories	Locknut, Shroud, Entry Thread Sealing Washer, Serrated Washer, Earth Tag, Adaptor/Reducer

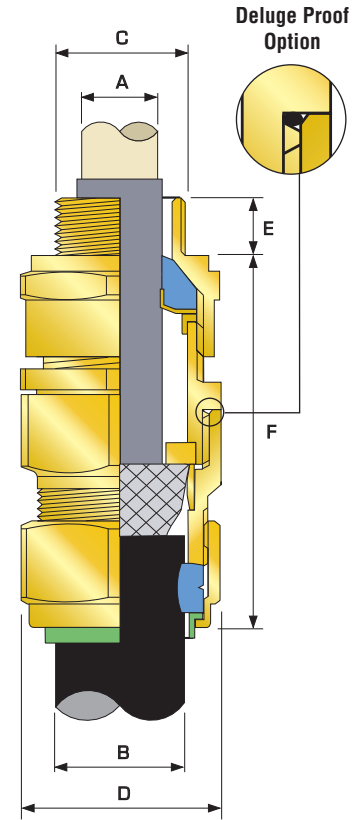

Note: Ingress Protection and Deluge Protection are essentially different and should not be confused with each other.

Note: Deluge Proof version available, ferrule colour coded "natural" for ease of identification

Cable Gland Selection Table

Cable Gland Size	Available Entry Threads 'C'			Minimum Thread Length 'E'	Cable Lead Sheath Diameter 'A'		Overall Cable Diameter 'B'		Armour Range		Across Flats 'D'		Nominal Protrusion Length 'F'	Ordering Reference (Brass Metric) #	PVC Shroud Reference*	Cable Gland Weight (Kgs)
	Standard		Option		Min	Max	Min	Max	Min	Max	Max	Max				
	Metric	NPT	NPT 2													
20S/16	M20	1/2"	3/4"	15.0	3.1	8.7	6.1	11.5	0.0	1.0	24.0	24.4	58.5	20S16E2FX1RA	PVC04	0.158
20S	M20	1/2"	3/4"	15.0	6.1	11.7	9.5	15.9	0.0	1.0	24.0	26.6	58.5	20SE2FX1RA	PVC04	0.158
20	M20	1/2"	3/4"	15.0	6.5	14.0	12.5	20.9	0.0	1.0	30.5	33.3	60.5	20E2FX1RA	PVC06	0.208
25S	M25	3/4"	1"	15.0	11.1	20.0	14.0	22.0	0.0	1.0	37.5	40.5	67.5	25SE2FX1RA	PVC09	0.330
25	M25	3/4"	1"	15.0	11.1	20.0	18.2	26.2	0.0	1.0	37.5	40.5	67.5	25E2FX1RA	PVC09	0.330
32	M32	1"	1-1/4"	15.0	17.0	26.3	23.7	33.9	0.0	1.0	46.0	51.0	69.5	32E2FX1RA	PVC11	0.463
40	M40	1-1/4"	1-1/2"	15.0	22.0	32.2	27.9	40.4	0.0	1.0	55.0	61.0	78.0	40E2FX1RA	PVC15	0.671
50S	M50	1-1/2"	2"	15.0	29.5	38.2	35.2	46.7	0.0	1.0	60.0	66.5	75.5	50SE2FX1RA	PVC18	0.760
50	M50	2"	2-1/2"	15.0	35.6	44.1	40.4	53.1	0.0	1.0	70.0	78.6	80.5	50E2FX1RA	PVC21	0.777
63S	M63	2"	2-1/2"	15.0	40.1	50.0	45.6	59.4	0.0	1.0	75.0	83.2	91.5	63SE2FX1RA	PVC23	1.369
63	M63	2-1/2"	3"	15.0	47.2	56.0	54.6	65.9	0.0	1.0	80.0	89.0	92.0	63E2FX1RA	PVC25	1.472
75S	M75	2-1/2"	3"	15.0	52.8	62.0	59.0	72.1	0.0	1.0	89.0	101.6	99.0	75SE2FX1RA	PVC28	2.119
75	M75	3"	3-1/2"	15.0	59.1	68.0	66.7	78.5	0.0	1.0	99.0	111.1	102.0	75E2FX1RA	PVC30	2.688
90	M90	3-1/2"	4"	15.0	66.6	80.0	76.2	90.4	0.0	1.6	114.0	128.6	120.0	90E2FX1RA	PVC32	4.281
100	M100	-	-	15.0	76.0	91.0	86.1	101.5	0.0	1.6	123.0	138.0	148.0	100E2FX1RA	150/50HST	4.674
115	M115	-	-	15.0	86.0	98.0	101.5	110.3	0.0	1.6	133.4	147.8	169.0	115E2FX1RA	180/60HST	7.085
130	M130	-	-	15.0	97.0	115.0	114.2	123.3	0.0	1.6	146.1	161.9	183.0	130E2FX1RA	180/60HST	8.382

All dimensions in millimetres

Note: *LSF Shrouds also available on request. Alternative armour clamping range available for non-standard armour sizes. Marine approvals including Lloyds, DNV & ABS are also available from CMP Products. # Other thread forms are available

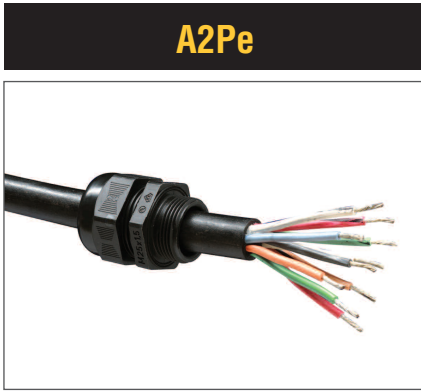

CMP V-TEC EX, EX L & EX M Cable Gland (A2Pe)
Code of protection EEx e II

The CMP V-TEC Type EX, EX L & M Range (A2Pe) of Increased Safety (Type 'e') Non-Metallic Cable Glands for Unarmoured and Screened Flexible Cables, is endorsed by an EC design type approval certificate in accordance with the requirements of EN50014 : 1997 & EN50019 : 1994 and the ATEX Directive 94/9/EC, concerning safety of Electrical Equipment, Products and Protection Systems for use in potentially explosive atmospheres (Hazardous Areas).

These Cable Gland products provide an environmental seal on the cable outer sheath and have been introduced as a cost effective solution for all indoor and outdoor cable installations in Zone 1 and Zone 2 Hazardous Areas, where Ex e or EEx e Code of Protection has been permitted. This cable gland is also suitable for use in conjunction with Ex de or EEx de equipment and apparatus which has an increased safety terminal chamber.

EC design type approval certificate number : PTB 99 ATEX 3112X and 3113X.

TECHNICAL DATA

Type Designation	V-TEC EX, EX L & EX M (A2Pe)
Classification, Hazardous Area	⊕ II 2G EEx e II
Compliance Code	EN50014 & EN50019
CENELEC Certification	PTB 99 ATEX 3112X & ATEX 3113X
UL Listing	E170293
Cable Gland Material	PA Polyamide, (Colour Black)
Seal Material	Chloroprene / Nitrile Rubber
Flame Retardancy Specification	VDE 0471/IEC 695 Part 2-1
Withstand Temperature tested	+750°C
Certified Continuous Operating Temperature Range	-20°C to +70°C
Ingress Protection	IP68 (at 5 bar) to VDE 0619 / IEC529
Cable Type	Unarmoured
Sealing Area	Outer Sheath
Sealing Technique	Controlled Seal with Strain Relief
Optional Accessories	Locknut, Adaptor / Reducer

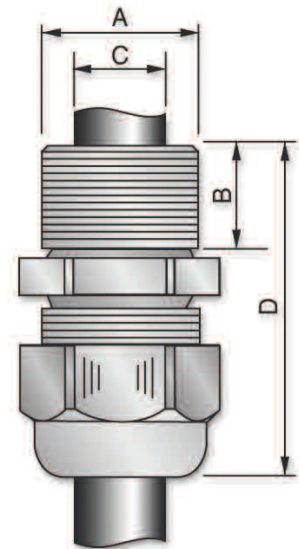

Design Features & Benefits

Wide Cable Sealing range, and additional strain relief for twist protection and high sealing demands
Seal Material - chloroprene/nitrile rubber . Flame-retardant to VDE 0471/IEC 695 Part 21.

Proven sealing technique ensuring a highly effective and reliable high integrity solution.
Metric Entry Threads to IEC 423, also available with Pg connecting thread to DIN 40430
Tested to VDE 0619, protection IP 68 at 5 bar . Test temperature 750°C



CMP V-TEC EX M Cable Glands (A2Pe) - Code of protection EEx e II

Size Ref.	Thread Size 'A'	Thread Length 'B'	Cable Acceptance Range 'C'		Overall Length 'D'		Across Flats	Across Corners	Weight (KG/100)	Pack QTY.
			Min	Max	Min	Max				
A2XMP1	M12	8.0	3.5	6.5	18.0	23.0	15.0	16.5	0.36	50
A2XMP2	M16	8.0	5.0	8.0	21.0	27.0	19.0	21.0	0.63	50
A2XMP3	M20	9.0	7.0	12.0	23.0	30.0	24.0	27.0	1.00	50
A2XMP4	M25	11.0	12.0	18.0	28.0	38.0	33.0	37.5	2.35	25
A2XMP5	M32	11.0	17.0	25.0	32.0	43.0	42.0	47.5	3.90	20

CMP V-TEC EX & EX L Cable Glands (A2Pe) - Code of protection EEx e II

Size Ref.	Thread Size 'A'	Thread Length 'B'		Cable Acceptance Range 'C'		Overall Length 'D'		Across Flats	Across Corners	Weight (KG/100)	Pack QTY.
		EX	EX L	Min	Max	Min	Max				
A2XP1 / A2XLP1	Pg 7	8.0	15.0	3.5	6.5	18.0	23.0	15.0	16.5	0.41	50
A2XP2 / A2XLP2	Pg 9	8.0	15.0	5.0	8.0	21.0	27.0	19.0	21.0	0.67	50
A2XP3 / A2XLP3	Pg 11	8.0	15.0	4.5	10.0	22.0	29.0	22.0	25.0	0.93	50
A2XP4 / A2XLP4	Pg 13.5	9.0	15.0	6.5	12.0	22.0	30.0	24.0	27.0	1.09	50
A2XP5 / A2XLP5	Pg 16	10.0	15.0	7.0	14.0	25.0	33.0	27.0	30.0	1.49	25
A2XP6 / A2XLP6	Pg 21	11.0	15.0	12.0	18.0	28.0	38.0	33.0	37.5	2.33	25
A2XP7 / A2XLP7	Pg 29	11.0	15.0	17.0	25.0	32.0	43.0	42.0	47.5	3.86	20
A2XP9 / A2XLP9	Pg 42	13.0	18.0	24.0	38.0	42.0	57.0	60.0	68.5	10.07	5
A2XP10 / A2XLP10	Pg 48	14.0	18.0	30.0	44.0	42.0	58.0	65.0	74.0	10.73	5

777 SERIES Insulated Adaptors

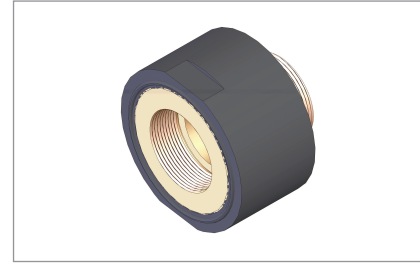
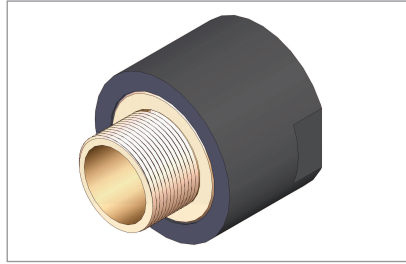

Insulated Adaptor Type 777 with Flameproof Ex d IIC & Increased Safety Ex e II forms of protection.

The CMP Type 777 Insulated Adaptor allows the Metallic Cable Gland, and ultimately the cable armour, to be effectively isolated from the equipment. The use of these Adaptors has proven to be an essential precaution in areas where electromagnetic 'noise' and circulating eddy currents 'stray' around any vulnerable cable system. Particularly relevant in Power Plants and in areas where highly sensitive instrumentation circuits are relied upon for interference free safety critical operations, the cable armour can still be connected to ground externally with the use of an earth tag fitted between the cable gland and insulated adaptor. This allows the user to design his system around a single point earthing strategy and allows the operator to perform tests on the earth circuit without disconnection of the elements installed. A General Purpose Industrial version is also available.

CMP 777 Insulated Adaptors are available in Brass, Aluminium or Stainless Steel and can be supplied for both Industrial and Hazardous Area applications, with Ex 'd' & Ex 'e' Component Approval.

777 Insulated Adaptor	Technical Data	
	Type	777
	Design Specification	BS 6121: Part 1: 1989, EN 50262:1999
	ATEX Certification Detail	SIRA 05 ATEX 1233U
	Code of Protection Category	ATEX (Ex) II 2 GD Ex d IIC & Ex e II Component, Zone 1, Zone 2, Zone 21, & Zone 22 - Gas Groups IIA, IIB, IIC
	IECEX Certification Detail	IECEX SIR 05.0044U
	Code of Protection Category	Ex d IIC / Ex e II / Ex tD A21 IP6X
	Compliance Standards	EN 60079-0, EN 60079-1, EN 60079-7, EN 61241-0, EN 61241-1, IEC 60079-0, IEC 60079-1, IEC 60079-7, IEC 61241-0, IEC 61241-1
	Continuous Operating Temperatures	-20°C to + 60°C
	Ingress Protection Rating	IP68
	Materials	Brass, Nickel Plated Brass, Aluminium, Stainless Steel
Accessories Included	Integral Entry Thread 'O' Ring Seal	
Optional Accessories	Locknut, Serrated Washer	

Product Selection Table *						
Ordering Reference	Male Thread Size	Minimum Thread Length	Female Thread Size	Maximum Bore Diameter	Nominal Protrusion Length	Overall Envelope Diameter
777DM2M2	M20 X 1.5	15	M20 X 1.5	14.3	36.1	40.0
777DM3M3	M25 X 1.5	15	M25 X 1.5	20.3	40.5	57.0
777DM4M4	M32 X 1.5	15	M32 X 1.5	26.8	40.6	57.0
777DM5M5	M40 X 1.5	15	M40 X 1.5	32.7	40.9	76.0
777DM6M6	M50 X 1.5	15	M50 X 1.5	44.6	41.2	76.0
777DM7M7	M63 X 1.5	15	M63 X 1.5	56.5	57.2	100.0
777DM8M8	M75 X 1.5	15	M75 X 1.5	65.2	57.2	100.0

All dimensions shown are in millimetres unless otherwise stated

Marked with ATEX certification details as standard. Alternative certification marking shown in the table below can be applied if requested at the time of ordering.

Additional Approvals	
GOST R Certificate Number	POCC GB.ГБ05.Б01912
CSA Approval Certificate	1055233 Class I ABCD, Class II EFG, IP68 TYPE 4X Exd / Ex e IIC

Note *: Other Thread Variations available on request. Please refer to ordering guide tables on page 161 for reference definitions



PX2K CABLE GLAND

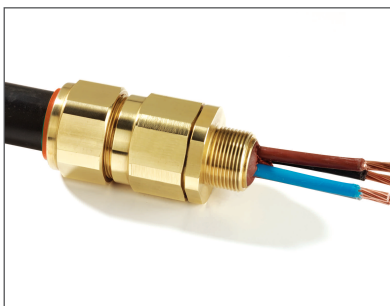

PX2K Flameproof Ex d, Increased Safety Ex e, Restricted Breathing Ex nR Compound Barrier Cable Gland

CMP Type PX2K Triple Certified Flameproof (Type 'd'), Increased Safety (Type 'e') and Restricted Breathing (Type 'nR') cable gland for use in Zone 1, Zone 2, Zone 21 and Zone 22 Hazardous Areas with all types of armoured cable providing a compound barrier seal around the cable conductors and an environmental seal on the cable outer sheath. The cable gland provides mechanical cable retention and electrical continuity via armour termination. A combined detachable armour cone and compound tube, together with AnyWay universal clamping ring arrangement allows the cable to be easily disconnected from the equipment, for maintenance and change out etc., and re-connected with the same consummate ease. This feature also facilitates remote make off procedures when the termination is to be conducted in confined spaces or in areas of restricted access.

The CMP PX2K cable gland is suitable for use with all forms of equipment protection permitted in Zone 1, Zone 2, Zone 21 & Zone 22 provided always that the prevailing code of practice for selection and installation is observed, e.g. IEC 60079-14.

The PX2K is supplied in kit form inclusive of two detachable armour cones. Stepped Cone is suitable for SWA cables, Grooved Cone is suitable for all other approved armoured cables.

TECHNICAL DATA	
Type	PX2K
Design Specification	BS 6121:Part 1:1989, EN 50262:1999
ATEX Certification	SIRA06ATEX1097X
Code of Protection Category	ATEX (E) II 2 GD Ex d IIC, Ex e II, Ex nR II, Ex tD A21 IP66 - Equipment Zone 1, Zone 2, Zone 21, & Zone 22 - Gas Groups IIA, IIB, IIC
Compliance Standards	EN 60079-0:2004, EN 60079-1:2004, EN 60079-7:2003, EN 60079-15:2003, EN 61241-0:2004, EN 61241-1:2004
IECEx Approval Number	IECEx SIR 06.0044X
Code of Protection Category	Ex d IIC, Ex e II, Ex nR II, Ex tD A21 IP66
Compliance Standards	IEC 60079-0:2004, IEC 60079-1:2003, IEC 60079-7:2001, IEC 60079-15:2005, IEC 61241-0:2004, IEC 61241-1:2004
GOST R Certificate Number	POCC GB. ГБ05.В01912
Code of Protection Category	Ex d IIC U, Ex e II U
Compliance Standards	ГОСТ Р 52350.0-2005, ГОСТ Р 52350.1-2005, ГОСТ Р 52350.7-2005
GGTN Permit Number	PPC 00-18262
GOST K Certificate Number	KZ7500052.05.01.00063
RoK Permit for Use Number	08-067693
Lloyds Approval Number	01/00172
DNV Approval Number	E-6157
ABS Approval Number	01-LD 234401-PDA
Continuous Operating Temperature	-60°C to +100°C
Ingress Protection Rating	IP66, IP67, IP68
Ingress Protection Document	5046 C549G
Deluge Protection Compliance	DTS01 : 91
Deluge Protection Document	5046 C549G-D
Cable Gland Material	Brass, Electroless Nickelplated Brass, Stainless Steel, Aluminium
Seal Material	CMP SOLO LSF Thermoplastic Elastomer / Epoxy Resin Barrier Compound
Cable Type	Wire Braid Armour, Single Wire Armour (SWA), Screened Flexible Wire Braid (e.g. CY / SY), Steel Tape Armour (STA) Pliable Wire Armour (PWA)
Armour Clamping	Detachables Compound Tube / Cone & AnyWay Universal Clamping Ring
Sealing Technique	Unique CMP "LRS"™ Outer Seal (Load Retention Seal)
Sealing Area(s)	Inner Compound Barrier & Cable Outer Sheath
Optional Accessories	Locknut, Shroud, Entry Thread Seal, Serrated Washer, Earth Tag, Adaptor/Reducer

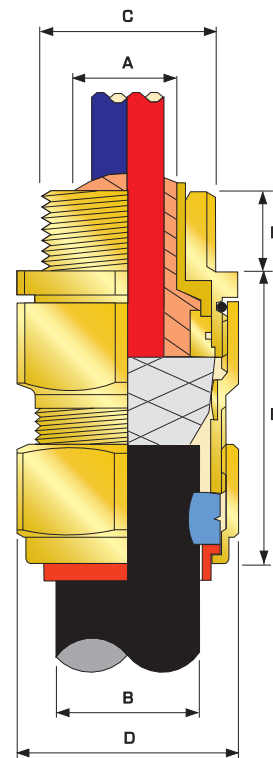

Note: Dedicated version for Steel Wire Armour type is PX2KW. Dedicated version for all other Armour types is PX2KX

Note: This standard design concept is also available with bi-code approvals, suitable for installation in systems complying with NEC wiring code rules.

Cable Gland Selection Table

Cable Gland Size	Available Entry Threads 'C'			Minimum Thread Length 'E'	Diameter Over Conductors 'A'	Number of Cores	Overall Cable Diameter 'B'		Armour Range †				Across Flats 'D'	Across Corners 'D'	Nominal Protrusion Length 'F'	Ordering Reference (Brass Metric) #	PVC Shroud Reference*	Cable Gland Weight (Kgs)		
	Standard	Option					Min	Max	Min	Max	Min	Max							Min	Max
		Metric	NPT																	
20S/16	M20	1/2"	3/4"	15.0	12.6	15	6.1	11.5	0.0	1.0	0.9	1.25	24.0	26.6	58.5	20S16PX2K1RA	PVC04	0.200		
20S	M20	1/2"	3/4"	15.0	12.6	15	9.5	15.9	0.0	1.0	0.9	1.25	24.0	26.6	58.5	20SPX2K1RA	PVC04	0.200		
20	M20	1/2"	3/4"	15.0	12.6	15	12.5	20.9	0.0	1.0	0.9	1.25	30.5	33.3	60.5	20PX2K1RA	PVC06	0.230		
25S	M25	3/4"	1"	15.0	17.5	29	14.0	22.0	0.0	1.0	1.25	1.6	37.5	40.5	67.5	25SPX2K1RA	PVC09	0.330		
25	M25	3/4"	1"	15.0	17.5	29	18.2	26.2	0.0	1.0	1.25	1.6	37.5	40.5	67.5	25PX2K1RA	PVC09	0.330		
32	M32	1"	1-1/4"	15.0	23.6	51	23.7	33.9	0.0	1.0	1.6	2.0	46.0	51.0	69.5	32PX2K1RA	PVC11	0.510		
40	M40	1-1/4"	1-1/2"	15.0	30.0	80	27.9	40.4	0.0	1.0	1.6	2.0	55.0	61.0	78.0	40PX2K1RA	PVC15	0.720		
50S	M50	1-1/2"	2"	15.0	36.6	122	35.2	46.7	0.0	1.0	2.0	2.5	60.0	66.5	75.5	50SPX2K1RA	PVC18	0.825		
50	M50	2"	2-1/2"	15.0	41.0	149	40.4	53.1	0.0	1.0	2.0	2.5	70.0	78.6	80.5	50PX2K1RA	PVC21	0.860		
63S	M63	2"	2-1/2"	15.0	47.9	205	45.6	59.4	0.0	1.0	2.0	2.5	75.0	83.2	91.5	63SPX2K1RA	PVC23	1.450		
63	M63	2-1/2"	3"	15.0	53.7	259	54.6	65.9	0.0	1.0	2.0	2.5	80.0	89.0	92.0	63PX2K1RA	PVC25	1.600		
75S	M75	2-1/2"	3"	15.0	59.8	320	59.0	72.1	0.0	1.0	2.0	2.5	89.0	101.6	99.0	75SPX2K1RA	PVC28	2.300		
75	M75	3"	3-1/2"	15.0	64.3	364	66.7	78.5	0.0	1.0	2.0	2.5	99.0	111.1	102.0	75PX2K1RA	PVC30	3.050		
90	M90	3"	3-1/2"	15.0	75.3	500	76.2	90.4	0.0	1.6	3.15	3.15	114.0	128.6	120.0	90PX2K1RA	PVC32	5.000		

All dimensions in millimetres

Note: *LSF Shrouds also available on request. †Alternative armour clamping range available for non-standard armour sizes. Marine approvals including Lloyds, DNV & ABS are also available from CMP Products. # Other thread forms are available

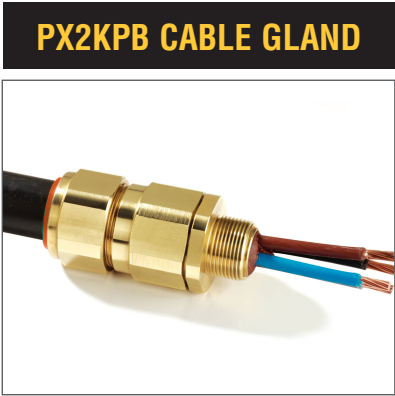

PX2KPB Flameproof Ex d, Increased Safety Ex e, Restricted Breathing Ex nR Compound Barrier Cable Gland

CMP Type PX2KPB Triple Certified Flameproof (Type 'd'), Increased Safety (Type 'e') and Restricted Breathing (Type 'nR') cable gland for use in Zone 1, Zone 2, Zone 21 and Zone 22 Hazardous Areas with all types of lead sheathed and armoured cable providing a compound barrier seal around the cable conductors and an environmental seal on the cable outer sheath. The cable gland provides mechanical cable retention and electrical continuity via armour termination, and also earth bonding of the inner Lead Covering or Lead Sheath. A combined detachable armour cone and compound tube, together with AnyWay universal clamping ring arrangement allows the cable to be easily disconnected from the equipment, for maintenance and change out etc., and re-connected with the same consummate ease. This feature also facilitates remote make off procedures when the termination is to be conducted in confined spaces or in areas of restricted access.

The CMP PX2KPB cable gland is suitable for use with all forms of equipment protection permitted in Zone 1, Zone 2, Zone 21 & Zone 22 provided always that the prevailing code of practice for selection and installation is observed, e.g. IEC 60079-14.

The PX2KPB is supplied in kit form inclusive of two detachable armour cones. Stepped Cone is suitable for SWA cables, Grooved Cone is suitable for all other approved armoured cables.

TECHNICAL DATA	
Type	PX2KPB
Design Specification	BS 6121:Part 1:1989, EN 50262:1999
ATEX Certification	SIRA06ATEX1097X
Code of Protection Category	ATEX II 2 GD Ex d IIC, Ex e II, Ex nR II, Ex tD A21 IP66 - Equipment Zone 1, Zone 2, Zone 21, & Zone 22 - Gas Groups IIA, IIB, IIC
Compliance Standards	EN 60079-0:2004, EN 60079-1:2004, EN 60079-7:2003, EN 60079-15:2003, EN 61241-0:2004, EN 61241-1:2004
IECEx Approval Number	IECEx SIR 06.0044X
Code of Protection Category	Ex d IIC, Ex e II, Ex nR II, Ex tD A21 IP66
Compliance Standards	IEC 60079-0:2004, IEC 60079-1:2003, IEC 60079-7:2001, IEC 60079-15:2005, IEC 61241-0:2004, IEC 61241-1:2004
Gost R Ex Certificate	POCC GB. ГБ05.В01912
Code of Protection Category	Ex d IIC U / Ex e II U
Compliance Standards	ГОСТ P 52520.0-2005,ГОСТ P 52520.1-2005,ГОСТ P 52520.7-2005
GGTN Permit Number	PPC 00-18262
GOST K Certificate Number	KZ7500052.05.01.00063
RoK Permit for Use Number	08-067693
Lloyds Approval Number	01/00172
DNV Approval Number	E-6157
ABS Approval Number	01-LD 234401-PDA
Continuous Operating Temperature	-60°C to +100°C
Ingress Protection Rating	IP66, IP67, IP68
Ingress Protection Document	5046 C549G
Deluge Protection Compliance	DTS01 : 91
Deluge Protection Document	5046 C549G-D
Cable Gland Material	Brass, Electroless Nickelplated Brass, Stainless Steel, Aluminium
Seal Material	CMP SOLO LSF Thermoplastic Elastomer / Epoxy Resin Barrier Compound
Cable Type	Lead Sheathed and Single Wire Armour (SWA), Aluminium Wire Armour (AWA), Steel Tape Armour (STA), Wire Braid Armour, Aluminium Strip Armour (ASA), Pliable Wire Armour (PWA)
Armour Clamping	Detachable Compound Tube / Cone & AnyWay Universal Clamping Ring
Sealing Technique	Unique CMP "LRS"™ Outer Seal (Load Retention Seal)
Sealing Area(s)	Inner Compound Barrier & Cable Outer Sheath
Optional Accessories	Locknut, Shroud, Entry Thread Seal, Serrated Washer, Earth Tag, Adaptor/Reducer

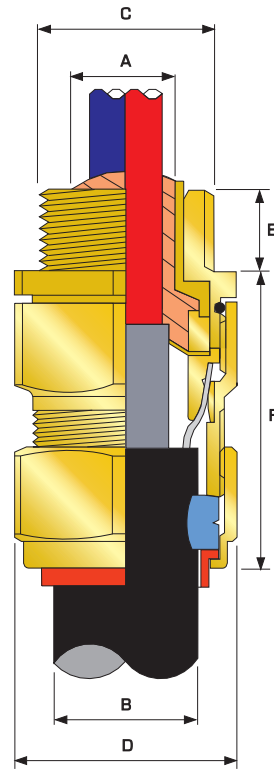

Note: Dedicated version for Steel Wire Armour type is PX2KWPB
Dedicated version for all other Armour types is PX2KXPB

Cable Gland Selection Table

Cable Gland Size	Available Entry Threads 'C'			Minimum Thread Length 'E'	Diameter Over Conductors 'A'	Number of Cores	Overall Cable Diameter 'B'		Armour Range †				Across Flats 'D'	Across Corners 'D'	Nominal Protrusion Length 'F'	Ordering Reference (Brass Metric) #	PVC Shroud Reference *	Cable Gland Weight (Kgs)		
	Standard	Option					Min	Max	Min	Max	Min	Max							Min	Max
		Metric	NPT																	
20S/16	M20	1/2"	3/4"	15.0	12.6	15	6.1	11.5	0.0	1.0	0.9	1.25	24.0	26.6	58.5	20S16PX2KPB1RA	PVC04	0.200		
20S	M20	1/2"	3/4"	15.0	12.6	15	9.5	15.9	0.0	1.0	0.9	1.25	24.0	26.6	58.5	20SPX2KPB1RA	PVC04	0.200		
20	M20	1/2"	3/4"	15.0	12.6	15	12.5	20.9	0.0	1.0	0.9	1.25	30.5	33.3	60.5	20PX2KPB1RA	PVC06	0.230		
25S	M25	3/4"	1"	15.0	17.5	29	14.0	22.0	0.0	1.0	1.25	1.6	37.5	40.5	67.5	25SPX2KPB1RA	PVC09	0.330		
25	M25	3/4"	1"	15.0	17.5	29	18.2	26.2	0.0	1.0	1.25	1.6	37.5	40.5	67.5	25PX2KPB1RA	PVC09	0.330		
32	M32	1"	1-1/4"	15.0	23.6	51	23.7	33.9	0.0	1.0	1.6	2.0	46.0	51.0	69.5	32PX2KPB1RA	PVC11	0.510		
40	M40	1-1/4"	1-1/2"	15.0	30.0	80	27.9	40.4	0.0	1.0	1.6	2.0	55.0	61.0	78.0	40PX2KPB1RA	PVC15	0.720		
50S	M50	1-1/2"	2"	15.0	36.6	122	35.2	46.7	0.0	1.0	2.0	2.5	60.0	66.5	75.5	50SPX2KPB1RA	PVC18	0.825		
50	M50	2"	2-1/2"	15.0	41.0	149	40.4	53.1	0.0	1.0	2.0	2.5	70.0	78.6	80.5	50PX2KPB1RA	PVC21	0.860		
63S	M63	2"	2-1/2"	15.0	47.9	205	45.6	59.4	0.0	1.0	2.0	2.5	75.0	83.2	91.5	63SPX2KPB1RA	PVC23	1.450		
63	M63	2-1/2"	3"	15.0	53.7	259	54.6	65.9	0.0	1.0	2.0	2.5	80.0	89.0	92.0	63PX2KPB1RA	PVC25	1.600		
75S	M75	2-1/2"	3"	15.0	59.8	320	59.0	72.1	0.0	1.0	2.0	2.5	89.0	101.6	99.0	75SPX2KPB1RA	PVC28	2.300		
75	M75	3"	3-1/2"	15.0	64.3	364	66.7	78.5	0.0	1.0	2.0	2.5	99.0	111.1	102.0	75PX2KPB1RA	PVC30	3.050		
90	M90	3"	3-1/2"	15.0	75.3	500	76.2	90.4	0.0	1.6	3.15	3.15	114.0	128.6	120.0	90PX2KPB1RA	PVC32	5.000		

All dimensions in millimetres

Note: *LSF Shrouds also available on request. †Alternative armour clamping range available for non-standard armour sizes. Marine approvals including Lloyds, DNV & ABS are also available from CMP Products. # Other thread forms are available



PXSS2K CABLE GLAND

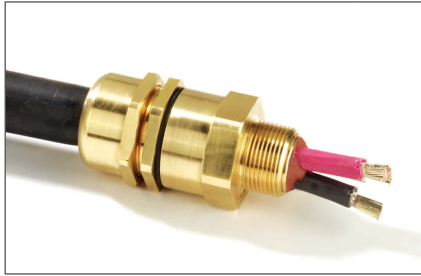

PXSS2K Flameproof Ex d, Increased Safety Ex e, Restricted Breathing Ex nR Compound Barrier Cable Gland

CMP Type PXSS2K Triple Certified Flameproof (Type 'd'), Increased Safety (Type 'e') and Restricted Breathing (Type 'nR') cable gland for use in Zone 1, Zone 2, Zone 21 and Zone 22 Hazardous Areas with all types of unarmoured cable providing a compound barrier seal around the cable conductors and an environmental seal on the cable outer sheath. The cable gland provides mechanical cable retention. A combined detachable spacer and compound tube allows the cable to be easily disconnected from the equipment, for maintenance and change out etc., and re-connected with the same consummate ease. This feature also facilitates remote make off procedures when the termination is to be conducted in confined spaces or in areas of restricted access.

The CMP PXSS2K cable gland is suitable for use with all forms of equipment protection permitted in Zone 1, Zone 2, Zone 21 & Zone 22 provided always that the prevailing code of practice for selection and installation is observed, e.g. IEC 60079-14.

TECHNICAL DATA	
Type	PXSS2K
Design Specification	BS 6121:Part 1:1989, EN 50262:1999, UL 514B, UL 886, UL 2225, UL 2227
ATEX Certification	SIRA06ATEX1097X
Code of Protection Category	ATEX (Ex) I I 2 GD Ex d IIC, Ex e II, Ex nR II, Ex tD A21 IP66 - Equipment Zone 1, Zone 2, Zone 21, & Zone 22 - Gas Groups IIA, IIB, IIC, ATEX (Ex) IM2, Exd I / Exe I
Compliance Standards	EN 60079-0: 2004, EN 60079-1: 2004, EN 60079-7: 2003, EN 60079-15: 2003, EN 61241-0: 2004 EN 61241-1: 2004
IECEx Approval Number	IECEx SIR 06.0044X
Code of Protection Category	Ex d IIC, Ex e II, Ex nR II, Ex tD A21 IP66, Ex d I, Ex e I
Compliance Standards	IEC 60079-0:2004, IEC 60079-1:2003, IEC 60079-7:2001, IEC 60079-15:2005, IEC 61241-0:2004, IEC 61241-1:2004
UL Listing File Number	FLDW.E201187, CYMX.E161256, EBMB.E253914
Code of Protection Category	Class I, Div 2, ABCD, Class II, Div 2, F & G, Class I, Zone 1, AEx d IIC, AEx e II
Compliance Standards	UL514B, UL 886, UL 2225, UL2227
CUL Listing File Number	FLDW7.E201187, CYMX7.E161256
Code of Protection Category	Class I, Div 2, ABCD, Class II, Div 2, F & G
Compliance Standards	UL514B, UL 886, UL 2225, UL2227
GOST R Certificate Number	POCC GB.ГБ05.В01912
Code of Protection Category	Ex d IIC U / Ex e II U
Compliance Standards	ГОСТ P 52350.0-2005,ГОСТ P 52350.1-2005,ГОСТ P 52350.7-2005
GGTN Permit Number	PPC 00-18262
GOST K Certificate Number	KZ7500052.05.01.00063
RoK Permit for Use Number	08-067693
Lloyds approval Number	01/00172
DNV Approval Number	E-6157
ABS Approval Number	01-LD 234401-PDA
Continuous Operating Temperature	-60°C to +100°C
Ingress Protection Rating	IP66, IP67, IP68
Ingress Protection Document	5046 C549J
Deluge Protection Compliance	DTS01 : 91
Deluge Protection Document	5046 C549J-D
NEMA Rating	NEMA 4X
Cable Gland Material	Brass, Electroless Nickelplated Brass, Stainless Steel, Aluminium
Seal Material	CMP SOLO LSF Thermoplastic Elastomer / Epoxy Resin Barrier Compound
Cable Type	Unarmoured
Sealing Technique	CMP Displacement Seal
Sealing Area(s)	Inner Compound Barrier & Cable Outer Sheath
Optional Accessories	Locknut, Shroud, Entry Thread Seal, Serrated Washer, Earth Tag, Adaptor/Reducer

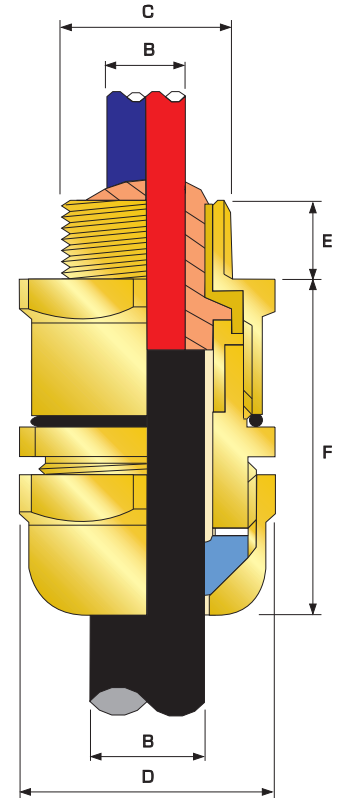

Note: This standard design concept is also available with bi-code approvals, suitable for installation in systems complying with NEC wiring code rules.

Cable Gland Selection Table

Cable Gland Size	Available Entry Threads 'C'			Minimum Thread Length 'E'	Diameter Over Conductors 'A'	Number of Cores	Overall Cable Diameter 'B'		Across Flats 'D'	Across Corners 'D'	Nominal Protusion Length 'F'	Ordering Reference (Brass Metric) #	PVC Shroud Reference*	Cable Gland Weight (Kgs)
	Standard		Option				Min	Max						
	Metric	NPT	NPT				Max	Max						
20S/16	M20	1/2"	3/4"	15.0	12.6	15	3.0	8.7	24.0	26.6	58.5	20S16PXSS2K1RA	PVC04	0.200
20S	M20	1/2"	3/4"	15.0	12.6	15	6.1	11.7	24.0	26.6	58.5	20SPXSS2K1RA	PVC04	0.200
20	M20	1/2"	3/4"	15.0	12.6	15	6.5	14.0	30.5	33.3	60.5	20PXSS2K1RA	PVC04	0.250
25	M25	3/4"	1"	15.0	17.5	29	11.1	20.0	37.5	40.5	67.5	25PXSS2K1RA	PVC09	0.403
32	M32	1"	1-1/4"	15.0	23.6	51	17.0	26.3	46.0	51.0	69.5	32PXSS2K1RA	PVC09	0.555
40	M40	1-1/4"	1-1/2"	15.0	30.0	80	22.0	32.1	55.0	61.0	78.0	40PXSS2K1RA	PVC15	0.600
50S	M50	1-1/2"	2"	15.0	36.6	122	29.5	38.2	60.0	66.5	75.5	50SPXSS2K1RA	PVC18	0.605
50	M50	2"	2-1/2"	15.0	41.0	149	35.6	44.1	70.0	78.6	80.5	50PXSS2K1RA	PVC21	0.620
63S	M63	2"	2-1/2"	15.0	47.9	205	40.1	50.1	75.0	83.2	91.5	63SPXSS2K1RA	PVC23	0.705
63	M63	2-1/2"	3"	15.0	53.7	259	47.2	56.0	80.0	89.0	92.0	63PXSS2K1RA	PVC25	0.730
75S	M75	2-1/2"	3"	15.0	59.8	320	52.8	62.0	89.0	101.6	99.0	75SPXSS2K1RA	PVC28	1.150
75	M75	3"	3-1/2"	15.0	64.3	364	59.1	68.0	99.0	111.1	102.0	75PXSS2K1RA	PVC30	1.300
90	M90	3"	3-1/2"	15.0	75.3	500	66.6	79.4	114.0	128.6	120.0	90PXSS2K1RA	PVC32	2.700

All dimensions in millimetres

Note: *LSF Shrouds also available on request. Marine approvals including Lloyds, DNV & ABS are also available from CMP Products. # Other thread forms are available

PXRC CABLE GLAND

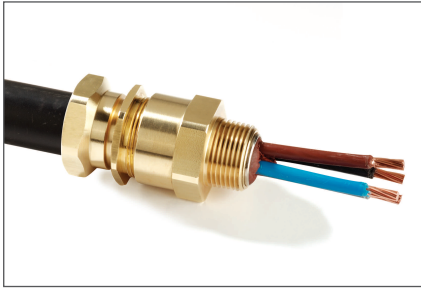

Type PXRC Tri-Star Flameproof Ex d, Increased Safety Ex e and Restricted Breathing Ex nR Conduit Connection Compound Barrier Cable Gland

CMP Type PXRC Triple Certified Flameproof (Type 'd'), Increased Safety (Type 'e') and Restricted Breathing (Type 'nR') indoor and outdoor cable gland for use in Zone 1, Zone 2, Zone 21 and Zone 22 Hazardous Areas with all types of unarmoured housed in rigid or flexible conduit systems. The cable gland provides a compound barrier seal around the cable conductors and is equipped with a rotating female connection for ease of conduit installation. The cable gland provides mechanical cable retention and electrical continuity via metallic conduit termination.

The CMP PXRC Conduit Connection Cable Gland is suitable for use with all forms of equipment protection permitted in Zone 1, Zone 2, Zone 21 & Zone 22 provided always that the prevailing code of practice for selection and installation is observed, e.g. IEC 60079-14.

TECHNICAL DATA	
Type	PXRC
Design Specification	BS 6121:Part 1:1989, EN 50262:1999
ATEX Certification	SIRA06ATEX1097X
Code of Protection Category	ATEX (Ex) II 2 GD Ex d IIC, Ex e II, Ex nR II, Ex tD A21 IP66, - Equipment Zone 1, Zone 2, Zone 21, & Zone 22 - Gas Groups IIA, IIB, IIC
Compliance Standards	EN 60079-0:2004, EN 60079-1:2004, EN 60079-7:2003, EN 60079-15:2003, EN 61241-0:2004, EN 61241-1:2004
IECEX Approval Number	IECEX SIR 06.0040X
Code of Protection Category	Ex d IIC, Ex e II, Ex nR II, Ex tD A21 IP66
Compliance Standards	IEC 60079-0:2004, IEC 60079-1:2003, IEC 60079-7:2001, IEC 60079-15:2005, IEC 61241-0:2004, IEC 61241-1:2004
Lloyds Approval Number	01/00172
ABS Approval Number	01-LD 234401-PDA
Continuous Operating Temperature	-60°C to +100°C
Ingress Protection Rating	IP66
Cable Gland Material	Brass, Electroless Nickel Plated Brass, Aluminium, Stainless Steel
Seal Material	CMP SOLO LSF Thermoplastic Elastomer
Cable Type	Unarmoured
Sealing Area(s)	Inner Compound Barrier
Optional Accessories	Locknut, Entry Thread Seal, Serrated Washer, Earth Tag, Adaptor/Reducer

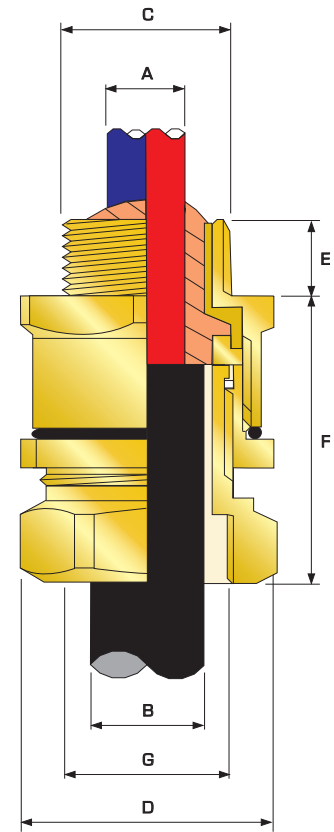

Cable Gland Selection Table

Cable Gland Size	Available Entry Threads 'C'			Minimum Thread Length 'E'	Standard Female Connection Thread 'G'	Diameter Over Conductors 'A'	Number of Cores	Overall Cable Diameter 'B'		Across Flats 'D'	Across Corners 'D'	Nominal Protrusion Length 'F'	Ordering Reference (Brass Metric) M X F #	Cable Gland Weight (Kgs)
	Standard	Option						Min	Max					
		Metric	NPT											
20S	M20	1/2"	3/4"	15.0	1/2"	12.6	15	9.5	15.9	24.0	26.6	21.0	20SPXRCIRA031	0.085
20	M20	1/2"	3/4"	15.0	1/2"	12.6	15	12.5	20.9	27.0	31.0	24.0	20PXRCIRA031	0.100
25	M25	3/4"	1"	15.0	3/4"	17.5	29	14.0	22.0	36.0	39.0	26.0	25PXRCIRA032	0.250
32	M32	1"	1-1/4"	15.0	1"	17.5	29	18.2	26.2	41.0	45.0	27.0	32PXRCIRA033	0.460
40	M40	1-1/4"	1-1/2"	15.0	1-1/4"	23.6	51	23.7	33.9	50.0	53.5	28.0	40PXRCIRA034	0.615
50S	M50	1-1/2"	2"	15.0	1-1/2"	30.0	80	27.9	40.4	55.0	61.0	29.0	50SPXRCIRA035	0.710
50	M50	2"	2-1/2"	15.0	2"	36.6	122	35.2	46.7	60.0	66.0	30.0	50PXRCIRA036	0.700
63S	M63	2"	2-1/2"	15.0	2"	41.0	149	40.4	53.1	70.0	77.5	30.0	63SPXRCIRA036	0.850
63	M63	2-1/2"	3"	15.0	2-1/2"	47.9	205	45.6	59.4	75.0	84.0	30.0	63PXRCIRA037	0.820
75S	M75	2-1/2"	3"	15.0	2-1/2"	53.7	259	54.6	65.9	79.0	87.0	32.0	75SPXRCIRA037	1.100
75	M75	3"	3-1/2"	15.0	3"	59.8	320	59.0	72.1	84.0	94.0	32.0	75PXRCIRA038	1.090
90	M90	3"	3-1/2"	15.0	3"	64.3	364	66.7	78.5	108.0	120.0	44.0	90PXRCIRA038	1.500

All dimensions in millimetres

Note: † Please specify male and female connection threads required when ordering. Marine approvals including Lloyds, DNV & ABS are also available from CMP Products.
Other thread forms are available.

MINING RANGE

■ APPLICATION

CMP have an in-depth knowledge of not only cable gland design, cable gland standards but also an equal in-depth knowledge of the various environments and industries in which our glands are to be installed. This knowledge gives CMP a distinct advantage in assisting potential customers to resolve queries and provide solutions to problems irrespective of the location be it Industrial, Surface Hazardous Group II or Underground Mining Group I.

The gland range offered accommodates all forms of cable used in mining locations. Unarmoured, single wire armoured and pliable wire armour manufactured in both standard and special materials to meet any application requirement.

The Group I Certified range of cable glands provide both the installer and OEM with the choice of using either a threaded entry cable

gland or a flange mounted version both being suitable for direct entry into the equipment. Where a threaded entry is provided in the equipment and a flanged mounted gland either already exists or is preferred or vice versa then we can supply a suitable adaptor which will convert from a threaded entry to a flanged entry by use of a MA/TF adaptor or alternatively a MA/FT when a threaded entry is preferred or required over a flange mounted entry.

For installations using non-filled cables or where the internal free volume exceeds 2 litres barrier type cable glands are available and provide a compound barrier seal around the conductors and an environmental seal on the cable outer sheath. Again these are available for all cable types and can be supplied with either a threaded or flanged entry.

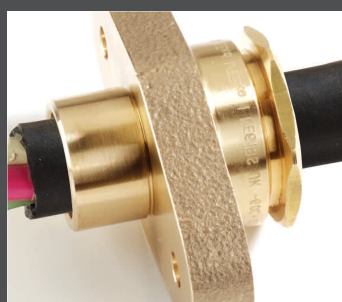

MA/FT, MA/B

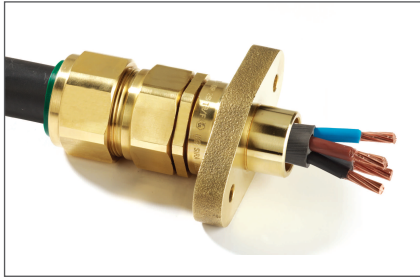

MA/FT, MA/B Adaptor Accessories

CMP Type MA/FT (spigot to thread) adaptors provide both a conversion for all cable glands from spigot entry to a threaded entry and also a method of converting from one size to another ie. 20mm threaded entry glands.

TECHNICAL DATA	
Type	MA/FT, MA/B
Design Specification	BS 6121:Part 1:1989, EN 50262:1999
ATEX Certification	SIRA02ATEX3421U
Code of Protection Category	ATEX Ex IM2 Ex d I, Ex e I
Compliance Standards	EN 50014:1997, EN 50018:2000, EN 50019:2000
GOST R Certificate Number	POCC GB.ГБ 05.В01913
Code of Protection Category	Ex d I U / Ex e I U
Compliance Standards	ГОСТ Р 52350.0-2005, ГОСТ Р 52350.1-2005, ГОСТ Р 52350.7-2005
GGTN Permit Number	PPC 00-18010
GOST K Certificate Number	KZ7500052.05.01.00063
RoK Permit for Use Number	08-067693
Continuous Operating Temperature	-60°C to +130°C
Ingress Protection Rating	IP66
Cable Gland material	Brass, Nickelplated Brass, Stainless Steel

MA/B

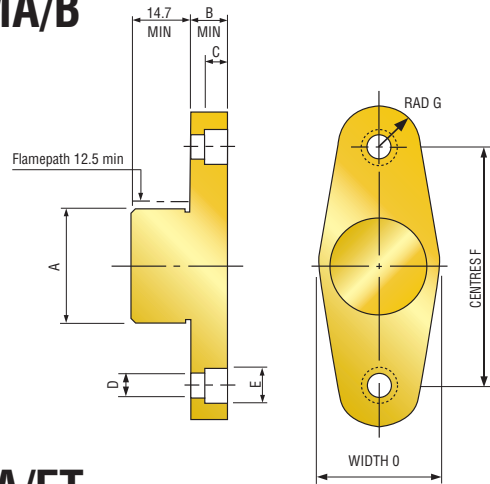

MA/FT

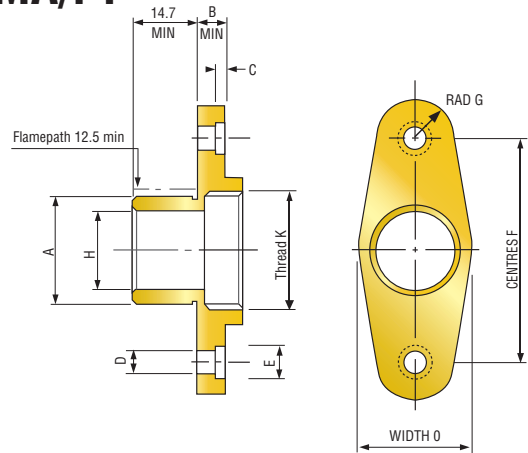

Spigot Selection Table

ADAPTOR SIZE	BORE DIAMETER 'H'	LENGTH 'B'	THREAD DIAMETER 'K'	SPIGOT DIAMETER 'A'	WIDTH 'O'	CENTRES 'F'	DIAMETER 'D'	DIAMETER 'E'	BORE DEPTH 'C'	RADIUS 'G'
20S	11.7	11.1	20.0	19.05	27.0	44.45	6.6	11.5	7.0	12.7
20	14.0	11.1	20.0	19.05	32.0	44.45	6.6	11.5	7.0	12.7
25	20.2	11.1	25.0	25.40	39.0	57.17	6.6	11.5	7.0	12.7
32	26.5	12.7	32.0	31.75	45.0	69.85	9.0	15.5	8.7	14.3
40	32.4	12.7	40.0	38.10	52.0	82.55	9.0	15.5	8.7	14.3
50S	38.4	14.5	50.0	50.80	58.0	95.25	11.0	19.0	10.5	17.5
50	44.3	14.5	50.0	50.80	64.0	95.25	11.0	19.0	10.5	17.5
63S	50.3	14.5	63.0	63.50	71.0	114.30	11.0	19.0	10.5	17.5
63	56.2	14.5	63.0	63.50	76.0	114.30	11.0	19.0	10.5	17.5
75S	62.2	18.0	75.0	76.20	83.0	127.00	14.0	21.0	13.5	17.5
75	68.2	18.0	75.0	76.20	88.0	127.00	14.0	21.0	13.5	17.5

All dimensions in millimetres

A2F/M CABLE GLAND

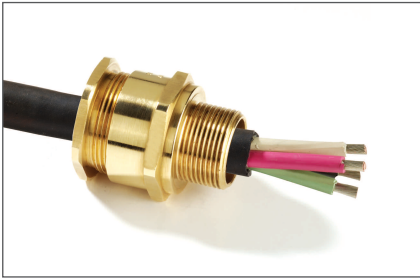

Type A2F/M Cable Gland

CMP Type A2F/M (Type 'd'), Increased Safety (Type 'e') cable gland for use in Zone 1 hazardous areas with un-armoured cable providing a combined flameproof seal and environmental seal on the cable outer sheath. This product provides full compatibility with restricted breathing equipment that rely upon flammable gases being excluded from the main enclosure.

The CMP A2F Cable Gland is suitable for use with all forms of equipment protection permitted in Zone 1 provided always that the prevailing code of practice for selection, installation and maintenance is observed, e.g. IEC 60079-14.

TECHNICAL DATA

Type	A2F/M
Design Specification	BS 6121: Part 1: 1989, EN 50262:1999
ATEX Certification	SIRA06ATEX1097X
Code of Protection Category	ATEX IM2, Exd I, Exe I
Compliance Standards	EN 60079-0:2004, EN 60079-1:2004, EN 60079-7:2003
IECEX Approval Number	IECEX SIR 06.0039X
Code of Protection Category	Ex d I, Ex e I
Compliance Standards	IEC 60079-0:2004, IEC 60079-1:2003, IEC 60079-7:2001
CSA Approval Certificate Number	1211841
Lloyds Approval Number	01/00172
DNV Approval Number	E-6157
ABS Approval Number	01-LD 234401-PDA
Continuous Operating Temperature	-60°C to +130°C
Ingress Protection Rating	IP66, IP67, IP68
Deluge Protection Compliance	DTS01:91
Cable Gland material	Brass, Electroless Nickel Plated Brass, Stainless Steel
Seal Material	CMP SOLO LSF Thermoplastic Elastomer
Cable Type	Unarmoured
Sealing Technique	CMP Displacement Seal
Sealing Area(s)	Cable Outer Sheath
Optional Accessories	Shroud, Earth Tag, Entry Thread Seal, Adaptor/Reducer, Serrated Washer, Locknut

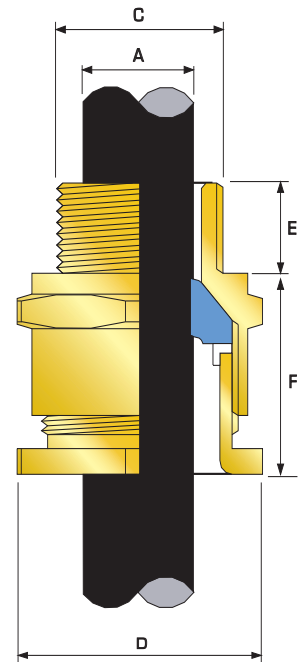

Cable Gland Selection Table

Cable Gland Size	Available Entry Threads 'C'			Minimum Thread Length 'E'	Cable Bedding Diameter 'A'		Across Flats 'D'	Across Corners 'D'	Nominal Protrusion Length 'F'	Ordering Reference (Brass Metric) #	PVC Shroud Reference*	Cable Gland Weight (Kgs)
	Standard		Option		Min	Max	Max	Max				
	Metric	NPT	NPT									
20S/16	M20	1/2"	3/4"	15.0	3.2	8.7	24.0	26.6	21.0	20S16A2F1RA/M	PVC04	0.054
20S	M20	1/2"	3/4"	15.0	6.1	11.7	24.0	26.6	21.0	20SA2F1RA/M	PVC04	0.054
20	M20	1/2"	3/4"	15.0	6.5	14.0	27.0	31.0	24.0	20A2F1RA/M	PVC05	0.059
25	M25	3/4"	1"	15.0	11.1	20.0	36.0	39.0	26.0	25SA2F1RA/M	PVC09	0.112
32	M32	1"	1-1/4"	15.0	17.0	26.3	41.0	45.0	27.0	32A2F1RA/M	PVC10	0.128
40	M40	1-1/4"	1-1/2"	15.0	23.5	32.2	50.0	53.5	28.0	40A2F1RA/M	PVC13	0.168
50S	M50	1-1/2"	2"	15.0	31.0	38.2	55.0	61.0	29.0	50SA2F1RA/M	PVC14	0.224
50	M50	2"	2-1/2"	15.0	35.6	44.1	60.0	66.0	30.0	50A2F1RA/M	PVC17	0.231
63S	M63	2"	2-1/2"	15.0	41.5	50.0	70.0	77.5	30.0	63SA2F1RA/M	PVC20	0.360
63	M63	2-1/2"	3"	15.0	47.2	56.0	75.0	84.0	30.0	63A2F1RA/M	PVC22	0.344
75S	M75	2-1/2"	3"	15.0	54.0	62.0	79.0	87.0	32.0	75SA2F1RA/M	PVC24	0.466
75	M75	3"	3-1/2"	15.0	61.1	68.0	84.0	94.0	32.0	75A2F1RA/M	PVC26	0.395
90	M90	3"	3-1/2"	15.0	66.6	79.4	108.0	120.0	44.0	90A2F1RA/M	PVC31	1.346
100	M100	4"	4-1/2"	15.0	76.0	91.0	122.0	138.0	48.0	100A2F1RA/M	150/50HST	1.575
115	M115	4-1/2"	5"	15.0	86.0	98.0	138.0	148.0	55.0	115A2F1RA/M	180/60HST	2.322
130	M130	5"	6"	15.0	97.0	115.0	154.0	178.0	62.0	130A2F1RA/M	180/60HST	3.400

All dimensions in millimetres

Note: *LSF Shrouds also available on request. # Other thread forms are available.

A2F/MF CABLE GLAND

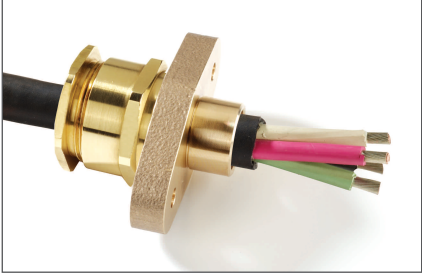

A2F/MF

CMP Type A2F/MF Group I Certified Flameproof Exd & Increased Safety Exe cable gland for use in Zone 1 Hazardous Areas with un-armoured cable providing a flange mounted cable gland with combined flameproof seal and environmental seal on the cable outer sheath.

TECHNICAL DATA	
Type	A2F/MF
Design Specification	BS 6121:Part 1:1989, EN 50262:1999
ATEX Certification	SIRA02ATEX3421U + SIRA06ATEX1097X
Code of Protection Category	ATEX IM2 Exd I, Exe I
Compliance Standards	EN 60079-0:2004, EN 60079-1:2004, EN 60079-7:2003, EN 50014:1997, EN 50018:2000, EN 50019:2000
Continuous Operating Temperature	-60°C to +130°C
Ingress Protection Rating	IP66, IP67, IP68
Cable Gland Material	Brass, Electroless Nickel Plated Brass, Stainless Steel
Seal Material	CMP SOLO LSF Thermoplastic Elastomer
Cable Type	Unarmoured
Sealing Technique	CMP Displacement Seal
Sealing Area(s)	Cable Outer Sheath

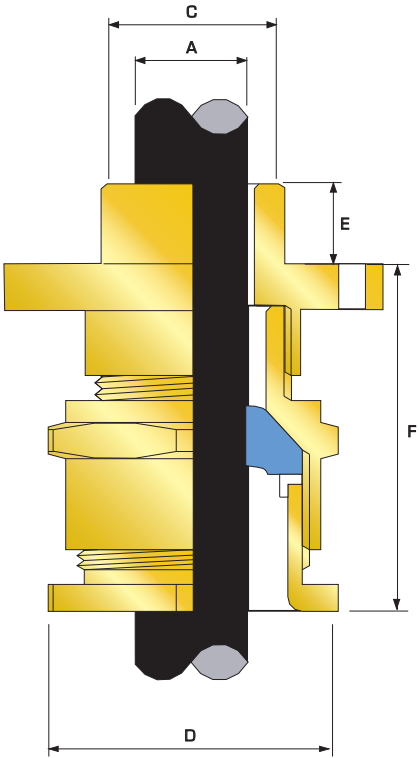

See page 136 for flange mounting dimensions

Cable Gland Selection Table

Cable Gland Size	Spigot Diam. 'C'	Minimum Spigot Length 'E'	Cable Bedding Diameter 'A'		Across Flats 'D'	Across Corners 'D'	Nominal Protrusion Length 'F'	Ordering Reference (Brass Metric)	Cable Gland Weight (Kgs)
			Min	Max	Max	Max			
20S	20.0	14.7	6.1	11.7	24.0	26.6	31.0	20SA2F1RA/MF	0.074
20	20.0	14.7	6.5	14.0	27.0	31.0	34.0	20A2F1RA/MF	0.079
25	25.0	14.7	11.1	20.0	36.0	39.0	36.0	25A2F1RA/MF	0.100
32	32.0	14.7	17.0	26.3	41.0	45.0	37.0	32A2F1RA/MF	0.438
40	40.0	14.7	23.5	32.2	50.0	53.5	38.0	40A2F1RA/MF	0.620
50S	50.0	14.7	31.0	38.2	55.0	61.0	39.0	50SA2F1RA/MF	0.730
50	50.0	14.7	35.6	44.1	60.0	66.0	40.0	50A2F1RA/MF	0.800
63S	63.0	14.7	41.5	50.0	70.0	77.5	40.0	63SA2F1RA/MF	1.040
63	63.0	14.7	47.2	56.0	75.0	84.0	40.0	63A2F1RA/MF	1.060
75S	75.0	14.7	54.0	62.0	79.0	87.0	42.0	75SA2F1RA/MF	1.220
75	75.0	14.7	61.1	68.0	84.0	94.0	42.0	75A2F1RA/MF	1.350

All dimensions in millimetres

Note: *LSF Shrouds also available on request.

E1FX/M CABLE GLAND

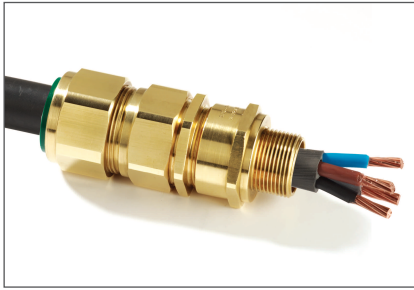

E1FX/M Mining Group I Flameproof Ex d & Increased Safety Ex e Cable Gland

CMP Type E1FX/M Group I Certified Flameproof Exd & Increased Safety Exe cable gland for use in Zone 1 Hazardous Areas with pliable wire armour (PWA) cable providing a cable gland with a flameproof seal on the cable inner sheath and an environmental seal on the cable outer sheath. The cable gland being suitable for armoured cables, provides mechanical cable retention and electrical continuity via armour wire termination. A detachable armour cone and AnyWay universal clamping ring arrangement allows the cable to be easily disconnected from the equipment, for maintenance and change out etc, and re-connected with the same consummate ease. This feature also facilitates remote make off procedures when the termination is to be conducted in confined spaces or in areas of restricted access. Separate tightening actions for the inner displacement seal and the armour termination affords maximum control over the pressure applied to the cable inner bedding. The CMP E1FT/MF cable gland is suitable for use with all forms of equipment protection permitted in Zone 1 provided always that the prevailing code of practice, installation and maintenance is observed ie. IEC60079-14.

TECHNICAL DATA

Type	E1FX/M
Design Specification	BS 6121:Part 1:1989, EN 50262:1999
ATEX Certification	SIRA06ATEX1097X
Code of Protection Category	ATEX IM2 Exd I / Exe I
Compliance Standards	EN 60079-0:2004, EN 60079-1:2004, EN 60079-7:2003
IECEX Approval Number	IECEX SIR 06.0043X
Code of Protection Category	Ex d I, Ex e I
Compliance Standards	IEC 60079-0:2004, IEC 60079-1:2003, IEC 60079-7:2001
GOST R Certificate Number	POCC GB.ГБ05.Б01913
Code of Protection Category	Ex d I U / Ex e I U
Compliance Standards	ГОСТ P 51330.0-99,ГОСТ P 51330.1-99, ГОСТ P 51330.8-99,ГОСТ P 52350.0-2005, ГОСТ P 52350.1-2005, ГОСТ P 52350.7-2005
GGTN Permit Number	PPC 00-18010
GOST K Certificate Number	KZ7500052.05.01.00063
RoK Permit for Use Number	08-067693
Continuous Operating Temperature	-60°C to +130°C
Ingress Protection Rating	IP66
Cable Gland Material	Brass, Electroless Nickel Plated Brass, Stainless Steel
Seal Material	CMP SOLO LSF Thermoplastic Elastomer
Cable Type	Pliable Wire Armour (PWA)
Armour Clamping	Detachable Armour Cone & AnyWay Universal Clamping Ring
Sealing Technique	CMP Inner Displacement Seal & Unique CMP "LRS"™ Outer Seal (Load Retention Seal)
Sealing Area(s)	Cable Inner & Cable Bedding Outer Sheath
Optional Accessories	Locknut, Shroud, Entry Thread Seal, Serrated Washer, Earth Tag, Adaptor/Reducer

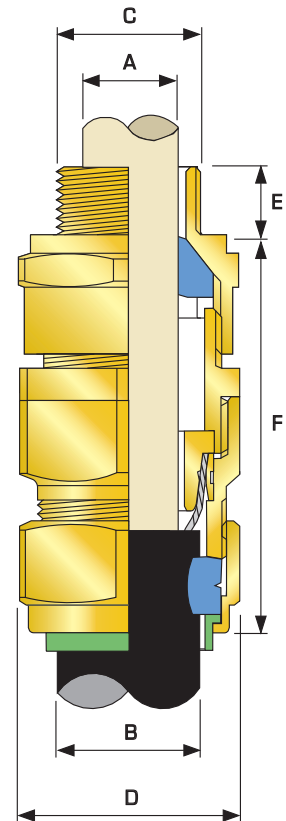

Cable Gland Selection Table

Cable Gland Size	Available Entry Threads 'C'			Minimum Thread Length 'E'	Cable Bedding Diameter 'A'		Overall Cable Diameter 'B'		Pliable Armour Wire		Across Flats 'D'	Across Corners 'D'	Nominal Protusion Length 'F'	Ordering Reference (Brass Metric) #	PVC Shroud Reference *	Cable Gland Weight (Kgs)
	Standard	Option			Min	Max	Min	Max	Min	Max						
		Metric	NPT													
20S	M20	1/2"	3/4"	15.0	6.1	11.7	9.5	15.9	0.0	7/0.45	24.0	26.6	58.5	20SE1FX1RA/M	PVC04	0.158
20	M20	1/2"	3/4"	15.0	6.5	14.0	12.5	20.9	0.0	7/0.45	30.5	33.3	60.5	20E1FX1RA/M	PVC06	0.208
25S	M25	3/4"	1"	15.0	11.1	20.0	14.0	22.0	0.0	7/0.45	37.5	40.5	67.5	25SE1FX1RA/M	PVC09	0.330
25	M25	3/4"	1"	15.0	11.1	20.0	18.2	26.2	0.0	7/0.45	37.5	40.5	67.5	25E1FX1RA/M	PVC09	0.330
32	M32	1"	1-1/4"	15.0	17.0	26.3	23.7	33.9	0.0	7/0.45	46.0	51.0	69.5	32E1FX1RA/M	PVC11	0.463
40	M40	1-1/4"	1-1/2"	15.0	22.0	32.2	27.9	40.4	0.0	7/0.71	55.0	61.0	78.0	40E1FX1RA/M	PVC15	0.671
50S	M50	1-1/2"	2"	15.0	29.5	38.2	35.2	46.7	0.0	7/0.71	60.0	66.5	75.5	50SE1FX1RA/M	PVC18	0.760
50	M50	2"	2-1/2"	15.0	35.6	44.1	40.4	53.1	0.9	7/0.71	70.0	78.6	80.5	50E1FX1RA/M	PVC21	0.777
63S	M63	2"	2-1/2"	15.0	40.1	50.0	45.6	59.4	0.9	7/0.71	75.0	83.2	91.5	63SE1FX1RA/M	PVC23	1.369
63	M63	2-1/2"	3"	15.0	47.2	56.0	54.6	65.9	0.9	7/0.71	80.0	89.0	92.0	63E1FX1RA/M	PVC25	1.472
75S	M75	2-1/2"	3"	15.0	52.8	62.0	59.0	72.1	1.25	7/0.71	89.0	101.6	99.0	75SE1FX1RA/M	PVC28	2.119
75	M75	3"	3-1/2"	15.0	59.1	68.0	66.7	78.5	1.25	7/0.71	99.0	111.1	102.0	75E1FX1RA/M	PVC30	2.688

All dimensions in millimetres

Note: *LSF Shrouds also available on request.

E1FX/MF CABLE GLAND

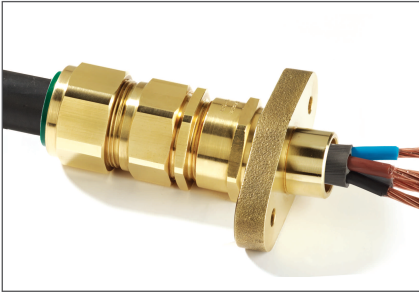

E1FX/MF Mining Group I Flanged Flameproof Ex d & Increased Safety Ex e Cable Gland

CMP Type E1FX/MF Group I Certified Flameproof Exd & Increased Safety Exe cable gland for use in Zone 1 Hazardous Areas with pliable wire armour (PWA) cable providing a flanged mounted cable gland with a flameproof seal on the cable inner sheath and an environmental seal on the cable outer sheath. The cable gland being suitable for SWA armoured cables, provides mechanical cable retention and electrical continuity via armour wire termination. A detachable armour cone and AnyWay universal clamping ring arrangement allows the cable to be easily disconnected from the equipment, for maintenance and change out etc., and re-connected with the same consummate ease. This feature also facilitates remote make off procedures when the termination is to be conducted in confined spaces or in areas of restricted access. Separate tightening actions for the inner displacement seal and the armour termination affords maximum control over the pressure applied to the cable inner bedding. The CMP E1FX/MF cable gland is suitable for use with all forms of equipment protection permitted in Zone 1 provided always that the prevailing code of practice. Installation and maintenance is observed ie. IEC60079-14.

TECHNICAL DATA	
Type	E1FX/MF
Design Specification	BS 6121:Part 1:1989, EN 50262:1999
ATEX Certification	SIRA06ATEX1097X and SIRA02ATEX3421U
Code of Protection Category	ATEX (Ex) I M2 Ex d I, Ex e I
Compliance Standards	EN 60079-0:2004, EN 60079-1:2004, EN 60079-7:2003
GOST R Certificate Number	POCC GB.ГБ05.В01913
Code of Protection Category	Ex d I U / Ex e I U
Compliance Standards	ГОСТ Р 51330.0-99, ГОСТ Р 51330.1-99, ГОСТ Р 51330.8-99, ГОСТ Р 52350.0-2005, ГОСТ Р 52350.1-2005, ГОСТ Р 52350.7-2005
GGTN Permit Number	PPC 00-18010
GOST K Certificate Number	KZ7500052.05.01.00063
RoK Permit for Use Number	08-067693
Continuous Operating Temperature	-60°C to +130°C
Ingress Protection Rating	IP66
Cable Gland Material	Brass, Electroless Nickel Plated Brass, Stainless Steel
Seal Material	CMP SOLO LSF Thermoplastic Elastomer
Cable Type	Pliable Wire Armour (PWA)
Armour Clamping	Detachable Armour Cone & AnyWay Universal Clamping Ring
Sealing Technique	CMP Inner Displacement Seal & Unique CMP "LRS"™ Outer Seal (Load Retention Seal)
Sealing Area(s)	Cable Inner & Cable Bedding Outer Sheath

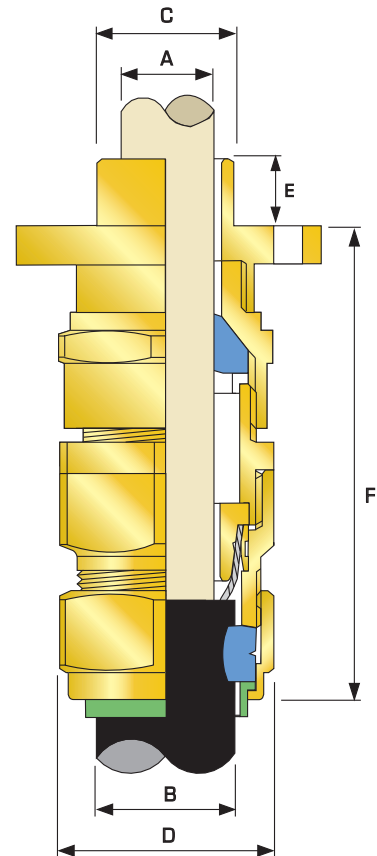

See page 136 for flange mounting dimensions

Cable Gland Selection Table

Cable Gland Size	Spigot Diam. 'C'	Minimum Spigot Length 'E'	Cable Bedding Diameter 'A'		Overall Cable Diameter 'B'		Pliable Armour Wire		Across Flats 'D'	Across Corners 'D'	Nominal Protrusion Length 'F'	Ordering Reference (Brass Metric)	PVC Shroud Reference*	Cable Gland Weight (Kgs)
			Min	Max	Min	Max			Max	Max				
20S	20.0	14.7	6.1	11.7	9.5	15.9	0.0	7/0.45	24.0	26.6	71.8	20SE1FX1RA/MF	PVC04	0.360
20	20.0	14.7	6.5	14.0	12.5	20.9	0.0	7/0.45	30.5	33.3	75.9	20E1FX1RA/MF	PVC06	0.420
25S	25.0	14.7	11.1	20.0	14.0	22.0	0.0	7/0.45	37.5	40.5	81.2	25SE1FX1RA/MF	PVC09	0.570
25	25.0	14.7	11.1	20.0	18.2	26.2	0.0	7/0.45	37.5	40.5	86.2	25E1FX1RA/MF	PVC09	0.570
32	32.0	14.7	17.0	26.3	23.7	33.9	0.0	7/0.45	46.0	51.0	86.4	32E1FX1RA/MF	PVC11	0.790
40	40.0	14.7	22.0	32.2	27.9	40.4	0.0	7/0.71	55.0	61.0	89.4	40E1FX1RA/MF	PVC15	1.150
50S	50.0	14.7	29.5	38.2	35.2	46.7	0.0	7/0.71	60.0	66.5	85.9	50SE1FX1RA/MF	PVC18	1.370
50	50.0	14.7	35.6	44.1	40.4	53.1	0.9	7/0.71	70.0	78.6	90.5	50E1FTX1RA/MF	PVC21	1.400
63S	63.0	14.7	40.1	50.0	45.6	59.4	0.9	7/0.71	75.0	83.2	94.5	63SE1FTX1RA/MF	PVC23	1.830
63	63.0	14.7	47.2	56.0	54.6	65.9	0.9	7/0.71	80.0	89.0	106.5	63E1FTX1RA/MF	PVC25	2.200
75S	75.0	14.7	52.8	62.0	59.0	72.1	1.25	7/0.71	89.0	101.6	109.0	75SE1FTX1RA/MF	PVC28	2.980
75	75.0	14.7	59.1	68.0	66.7	78.5	1.25	7/0.71	99.0	111.1	112.0	75E1FX1RA/MF	PVC30	3.520

All dimensions in millimetres

Note: *LSF Shrouds also available on request. Marine approvals including Lloyds, DNV & ABS are also available from CMP Products.

E1FW/M CABLE GLAND

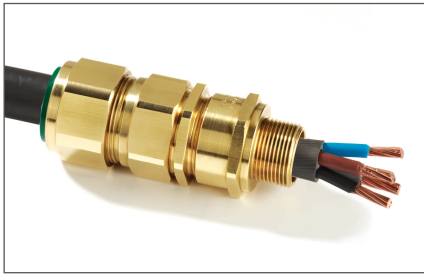

E1FW/M Flameproof Ex d, Increased Safety Ex e Cable Gland

CMP Type E1FW/M Group I Certified Flameproof (Type 'd', Group I), Increased Safety (Type 'e') cable gland for use in Zone 1 Hazardous Areas with Single Wire Armour (SWA) cable. This cable gland provides a flameproof seal on the cable inner bedding and in addition the gas tight seal has been tested to prove compatibility with restricted breathing equipment that relies upon flammable gases being excluded from the main enclosure. The cable gland allows mechanical cable retention and earth continuity via the cable armour termination. Separate tightening actions for the inner displacement seal and the armour termination afford maximum control over the pressure applied to the cable bedding, and also allows the effectiveness of the gas tight seal to be tested. A detachable armour cone and AnyWay clamping ring arrangement facilitates remote make off and enables the cable to be disconnected from the equipment. An environmental / load retention seal is provided on the cable outer sheath.

TECHNICAL DATA

Type	E1FW/M
Design Specification	BS 6121:Part 1:1989, EN 50262:1999
ATEX Certification	SIRA06ATEX1097X
Code of Protection Category	ATEX IM2 Exd I / Exe I
Compliance Standards	EN 60079-0:2004, EN 60079-1:2004, EN 60079-7:2003
IECEX Approval Number	IECEX SIR 06.0043X
Code of Protection Category	Ex d I, Ex e I
Compliance Standards	IEC 60079-0:2004, IEC 60079-1:2003, IEC 60079-7:2001
GOST R Certificate Number	POCC GB.ГБ05.В01913
Code of Protection Category	Ex d I U / Ex e I U
Compliance Standards	ГОСТ P 51330.0-99,ГОСТ P 51330.1-99, ГОСТ P 51330.8-99,ГОСТ P 52350.0-2005, ГОСТ P 52350.1-2005, ГОСТ P 52350.7-2005
GGTN Permit Number	PPC 00-18010
GOST K Certificate Number	KZ7500052.05.01.00063
RoK Permit for Use Number	08-067693
Continuous Operating Temperature	-60°C to +130°C
Ingress Protection Rating	IP66
Cable Gland Material	Brass, Electroless Nickel Plated Brass, Stainless Steel
Seal Material	CMP SOLO LSF Thermoplastic Elastomer
Cable Type	Single Wire Armour (SWA)
Armour Clamping	Detachable Armour Cone & AnyWay Universal Clamping Ring
Sealing Technique	CMP Inner Displacement Seal & Unique CMP "LRS"™ Outer Seal (Load Retention Seal)
Sealing Area(s)	Cable Inner & Cable Bedding Outer Sheath
Optional Accessories	Locknut, Shroud, Entry Thread Seal, Serrated Washer, Earth Tag, Adaptor/Reducer

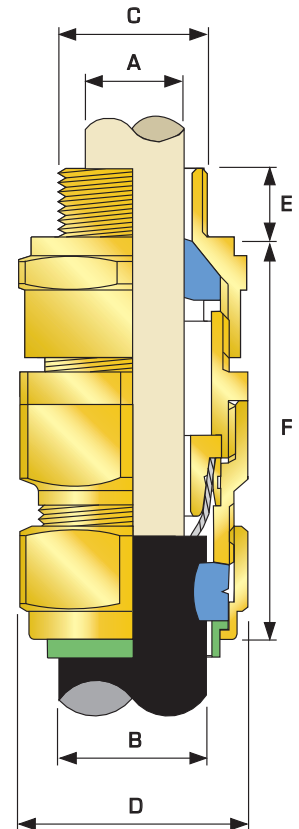

Cable Gland Selection Table

Cable Gland Size	Available Entry Threads 'C'			Minimum Thread Length 'E'	Cable Bedding Diameter 'A'		Overall Cable Diameter 'B'		Standard Armour Range †		Across Flats 'D'	Across Corners 'D'	Nominal Protrusion Length 'F'	Ordering Reference (Brass Metric) #	PVC Shroud Reference *	Cable Gland Weight (Kgs)
	Standard	Option			Min	Max	Min	Max	Min	Max						
		Metric	NPT													
20S	M20	1/2"	3/4"	15.0	6.1	11.7	9.5	15.9	0.90	1.25	26.6	26.6	58.5	20SE1FW1RA/M	PVC04	0.157
20	M20	1/2"	3/4"	15.0	6.5	14.0	12.5	20.9	0.90	1.25	33.3	33.3	60.5	20E1FW1RA/M	PVC06	0.206
25S	M25	3/4"	1"	15.0	11.1	20.0	14.0	22.0	1.25	1.60	40.5	40.5	67.5	25SE1FW1RA/M	PVC09	0.325
25	M25	3/4"	1"	15.0	11.1	20.0	18.2	26.2	1.25	1.60	40.5	40.5	67.5	25E1FW1RA/M	PVC09	0.325
32	M32	1"	1-1/4"	15.0	17.0	26.3	23.7	33.9	1.60	2.00	51.0	51.0	69.5	32E1FW1RA/M	PVC11	0.452
40	M40	1-1/4"	1-1/2"	15.0	22.0	32.2	27.9	40.4	1.60	2.00	61.0	61.0	78.0	40E1FW1RA/M	PVC15	0.657
50S	M50	1-1/2"	2"	15.0	29.5	38.2	35.2	46.7	2.00	2.50	66.5	66.5	75.5	50SE1FW1RA/M	PVC18	0.734
50	M50	2"	2-1/2"	15.0	35.6	44.1	40.4	53.1	2.00	2.50	78.6	78.6	80.5	50E1FW1RA/M	PVC21	0.748
63S	M63	2"	2-1/2"	15.0	40.1	50.0	45.6	59.4	2.00	2.50	83.2	83.2	91.5	63SE1FW1RA/M	PVC23	1.337
63	M63	2-1/2"	3"	15.0	47.2	56.0	54.6	65.9	2.00	2.50	89.0	89.0	92.0	63E1FW1RA/M	PVC25	1.436
75S	M75	2-1/2"	3"	15.0	52.8	62.0	59.0	72.1	2.00	2.50	101.6	101.6	99.0	75SE1FW1RA/M	PVC28	2.073
75	M75	3"	3-1/2"	15.0	59.1	68.0	66.7	78.5	2.00	2.50	111.1	111.1	102.0	75E1FW1RA/M	PVC30	2.622

All dimensions in millimetres

Note: * LSF Shrouds also available on request. † Alternative armour clamping range available for non-standard armour sizes. Marine approvals including Lloyds, DNV & ABS are also available from CMP Products. # Other thread forms are available.

E1FW/MF CABLE GLAND



E1FW/MF Group I Mining Flameproof Ex d & Increased Safety Ex e Flanged Cable Gland.

CMP Type E1FW/MF Group I Certified Flameproof Exd & Increased Safety Exe cable gland for use in Zone 1 Hazardous Areas with single wire armour (SWA) cable providing a flanged mounted cable gland with a flameproof seal on the cable inner sheath and an environmental seal on the cable outer sheath. The cable gland being suitable for armoured cables, provides mechanical cable retention and electrical continuity via armour wire termination. A detachable armour cone and AnyWay universal clamping ring arrangement allows the cable to be easily disconnected from the equipment, for maintenance and change out etc, and re-connected with the same consummate ease. This feature also facilitates remote make off procedures when the termination is to be conducted in confined spaces or in areas of restricted access. Separate tightening actions for the inner displacement seal and the armour termination affords maximum control over the pressure applied to the cable inner bedding. The CMP E1FW/MF Cable Gland is suitable for use with all forms of equipment protection permitted in Zone 1 provided always that the prevailing code of practice. Installation and maintenance is observed ie. IEC60079-14.

TECHNICAL DATA	
Type	E1FW/MF
Design Specification	BS 6121:Part 1:1989, EN 50262:1999
ATEX Certification	SIRA06ATEX1097X and SIRA02ATEX3421U
Code of Protection Category	ATEX I M2 Ex d I, Ex e I
Compliance Standards	EN 60079-0:2004, EN 60079-1:2004, EN 60079-7:2003
GOST R Certificate Number	POCC GB.ГБ05.В01913
Code of Protection Category	Ex d I U / Ex e I U
Compliance Standards	ГОСТ Р 51330.0-99, ГОСТ Р 51330.1-99, ГОСТ Р 51330.8-99, ГОСТ Р 52350.0-2005, ГОСТ Р 52350.1-2005, ГОСТ Р 52350.7-2005
GGTN Permit Number	PPC 00-18010
GOST K Certificate Number	KZ7500052.05.01.00063
RoK Permit for Use Number	08-067693
Continuous Operating Temperature	-60°C to +130°C
Ingress Protection Rating	IP66
Cable Gland Material	Brass, Electroless Nickel Plated Brass, Stainless Steel
Seal Material	CMP SOLO LSF Thermoplastic Elastomer
Cable Type	Single Wire Armour (SWA)
Armour Clamping	Detachable Armour Cone & AnyWay Universal Clamping Ring
Sealing Technique	CMP Inner Displacement Seal & Unique CMP "LRS"™ Outer Seal (Load Retention Seal)
Sealing Area(s)	Cable Inner & Cable Bedding Outer Sheath

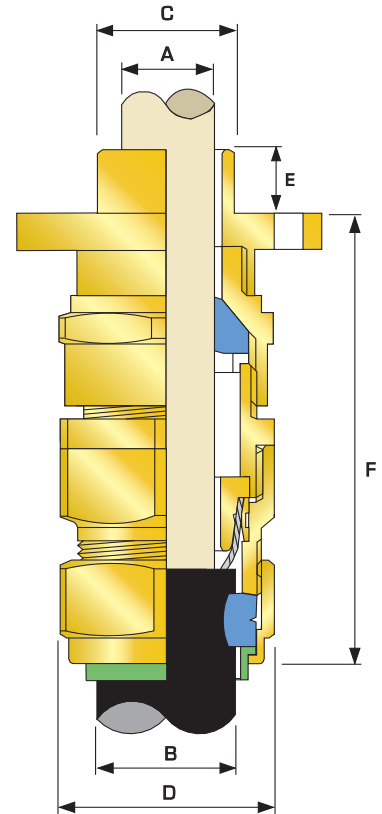

See page 136 for flange mounting dimensions

Cable Gland Selection Table

Cable Gland Size	Spigot Diam. 'C'	Minimum Spigot Length 'E'	Cable Bedding Diameter 'A'		Overall Cable Diameter 'B'		Armour Range †		Across Flats 'D'	Across Corners 'D'	Nominal Protrusion Length 'F'	Ordering Reference (Brass Metric)	PVC Shroud Reference*	Cable Gland Weight (Kgs)
			Min	Max	Min	Max	Min	Max						
20S	20.0	14.7	6.1	11.7	9.5	15.9	0.90	1.25	24.0	26.6	68.5	20SE1FW1RA/MF	PVC04	0.360
20	20.0	14.7	6.5	14.0	12.5	20.9	0.90	1.25	30.5	33.3	70.5	20E1FW1RA/MF	PVC04	0.420
25S	25.0	14.7	11.1	20.0	14.0	22.0	1.25	1.60	37.5	40.5	77.5	25SE1FW1RA/MF	PVC06	0.570
25	25.0	14.7	11.1	20.0	18.2	26.2	1.25	1.60	37.5	40.5	77.5	25E1FW1RA/MF	PVC09	0.570
32	32.0	14.7	17.0	26.3	23.7	33.9	1.60	2.00	46.0	51.0	79.5	32E1FW1RA/MF	PVC09	0.790
40	40.0	14.7	22.0	32.2	27.9	40.4	1.60	2.00	55.0	61.0	88.0	40E1FW1RA/MF	PVC11	1.150
50S	50.0	14.7	29.5	38.2	35.2	46.7	2.00	2.50	60.0	66.5	85.5	50SE1FW1RA/MF	PVC15	1.370
50	50.0	14.7	35.6	44.1	40.4	53.1	2.00	2.50	70.0	78.6	90.5	50E1FW1RA/MF	PVC18	1.400
63S	63.0	14.7	40.1	50.0	45.6	59.4	2.00	2.50	75.0	83.2	101.5	63SE1FW1RA/MF	PVC21	1.830
63	63.0	14.7	47.2	56.0	54.6	65.9	2.00	2.50	80.0	89.0	102.0	63E1FW1RA/MF	PVC23	2.200
75S	75.0	14.7	52.8	62.0	59.0	72.1	2.00	2.50	89.0	101.6	109.0	75SE1FW1RA/MF	PVC25	2.980
75	75.0	14.7	59.1	68.0	66.7	78.5	2.00	2.50	99.0	111.1	112.0	75E1FW1RA/MF	PVC28	3.520

All dimensions in millimetres

Note: *LSF Shrouds also available on request. †Alternative armour clamping range available for non-standard armour sizes. Marine approvals including Lloyds, DNV & ABS are also available from CMP Products.

PXSS2K/M CABLE GLAND

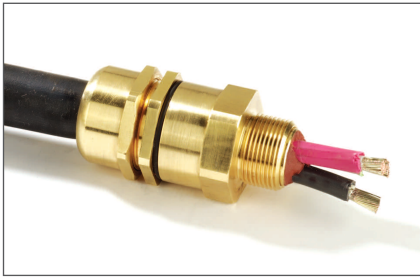

PXSS2K/M Flameproof Cable Gland

CMP Type PXSS2K Dual Certified Flameproof Type 'd', Group I and Increased Safety Type 'e' indoor and outdoor cable gland for use in Zone 1 Hazardous Areas with all types of UN-armoured cable providing a compound barrier seal around the conductors and an environmental seal on the cable outer sheath. The cable gland being suitable for use with un-armoured cables provides mechanical cable retention. The CMP PXSS2K/M cable gland is suitable for use with all forms of equipment protection permitted in Zone 1 provided always that the prevailing code of practice for selection, installation and maintenance is observed, e.g. IEC 60079-14.

TECHNICAL DATA

Type	PXSS2K
Design Specification	BS 6121:Part 1:1989, EN 50262:1999, UL 514B, UL 886, UL 2225, UL 2227
ATEX Certification	SIRA06ATEX1097X
Code of Protection Category	ATEX IM2, Exd I / Exe I
Compliance Standards	EN 60079-0:2004, EN 60079-1: 2004, EN 60079-7: 2003
IECEx Approval Number	IECEx SIR 06.0044X
Code of Protection Category	Ex d I, Ex e I
Compliance Standards	IEC 60079-0:2004, IEC 60079-1:2003, IEC 60079-7:2001
GOST R Certificate Number	POCC GB.ГБ05.В01913
Code of Protection Category	Ex d I U / Ex e I U
Compliance Standards	ГОСТ P 51330.0-99, ГОСТ P 51330.1-99, ГОСТ P 51330.8-99, ГОСТ P 52350.0-2005, ГОСТ P 52350.1-2005, ГОСТ P 52350.7-2005
GGTN Permit Number	PPC 00-18010
GOST K Certificate Number	KZ7500052.05.01.00063
RoK Permit for Use Number	08-067693
Lloyds approval Number	01/00172
DNV Approval Number	E-6157
ABS Approval Number	01-LD 234401-PDA
Continuous Operating Temperature	-60°C to +100°C
Ingress Protection Rating	IP66, IP67, IP68
Ingress Protection Document	5046 C549J
Deluge Protection Compliance	DTS01 : 91
Deluge Protection Document	5046 C549J-D
NEMA Rating	NEMA 4X
Cable Gland Material	Brass, Electroless Nickel Plated Brass, Stainless Steel
Seal Material	CMP SOLO LSF Thermoplastic Elastomer / Epoxy Resin Barrier Compound
Cable Type	Unarmoured, Non-Armoured
Sealing Technique	CMP Displacement Seal
Sealing Area(s)	Inner Compound Barrier & Cable Outer Sheath
Optional Accessories	Locknut, Adaptor/Reducer, Earth Tag, Shroud, Entry Thread Seal, Serrated Washer

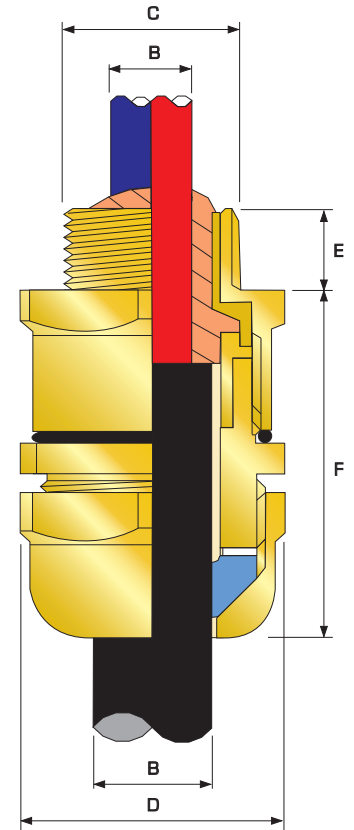

Cable Gland Selection Table

Cable Gland Size	Available Entry Threads 'C'			Minimum Thread Length 'E'	Max. dia. Over Conductors & Max. No. of Cores 'A'		Overall Cable Diameter 'B'		Across Flats 'D'	Across Corners 'D'	Nominal Protrusion Length 'F'	Ordering Reference (Brass Metric)	PVC Shroud Reference*	Cable Gland Weight (Kgs)
	Standard	Option			Dia.	Cores	Min	Max						
	Metric	NPT	NPT											
20S	M20	1/2"	3/4"	15.0	12.6	15	6.1	11.7	24.0	26.6	58.5	20PXSS2K1RA/M	PVC04	0.200
20	M20	1/2"	3/4"	15.0	12.6	15	6.5	14.0	30.5	33.3	60.5	20PXSS2K1RA/M	PVC04	0.250
25	M25	3/4"	1"	15.0	17.5	29	11.1	20.0	37.5	40.5	67.5	25PXSS2K1RA/M	PVC09	0.403
32	M32	1"	1-1/4"	15.0	23.6	51	17.0	26.3	46.0	51.0	69.5	32PXSS2K1RA/M	PVC09	0.555
40	M40	1-1/4"	1-1/2"	15.0	30.0	80	22.0	32.1	55.0	61.0	78.0	40PXSS2K1RA/M	PVC15	0.600
50S	M50	1-1/2"	2"	15.0	36.6	122	29.5	38.2	60.0	66.5	75.5	50PXSS2K1RA/M	PVC18	0.605
50	M50	2"	2-1/2"	15.0	41.0	149	35.6	44.1	70.0	78.6	80.5	50PXSS2K1RA/M	PVC21	0.620
63S	M63	2"	2-1/2"	15.0	47.9	205	40.1	50.1	75.0	83.2	91.5	63PXSS2K1RA/M	PVC23	0.705
63	M63	2-1/2"	3"	15.0	53.7	259	47.2	56.0	80.0	89.0	92.0	63PXSS2K1RA/M	PVC25	0.730
75S	M75	2-1/2"	3"	15.0	59.8	320	52.8	62.0	89.0	101.6	99.0	75PXSS2K1RA/M	PVC28	1.150
75	M75	3"	3-1/2"	15.0	64.3	364	59.1	68.0	99.0	111.1	102.0	75PXSS2K1RA/M	PVC30	1.300

All dimensions in millimetres

Note: *LSF Shrouds also available on request. Marine approvals including Lloyds, DNV & ABS are also available from CMP Products.

PXSS2K/MF CABLE GLAND

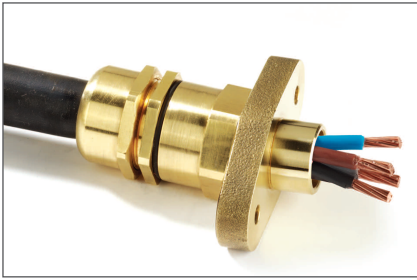

Type PXSS2K/MF Cable Gland

CMP Type PXSS2K/MF Group I Certified Flameproof Exd & Increased Safety Exe cable gland for use in Zone 1 Hazardous Areas with un-armoured cable providing a flange mounted cable gland with combined flameproof seal and environmental seal on the cable outer sheath.

TECHNICAL DATA	
Type	PXSS2K/MF
Design Specification	BS 6121: Part 1: 1989, EN 50262:1999
ATEX Certification	SIRA06ATEX1097X and SIRA02ATEX3421U
Code of Protection Category	ATEX Ex IM2, Ex d I, Ex e I
Compliance Standards	EN 60079-0: 2006, EN 60079-1:2004, EN 60079-7: 2003
Continuous Operating Temperature	-60°C to +100°C
Ingress Protection Rating	IP66
Cable Gland Material	Brass, Electroless Nickel Plated Brass, Stainless Steel
Seal Material	CMP SOLO LSF Thermoplastic Elastomer / Epoxy Resin Barrier Compound
Cable Type	Unarmoured
Sealing Technique	CMP Displacement Seal
Sealing Area(s)	Inner Compound Barrier & Cable Outer Sheath

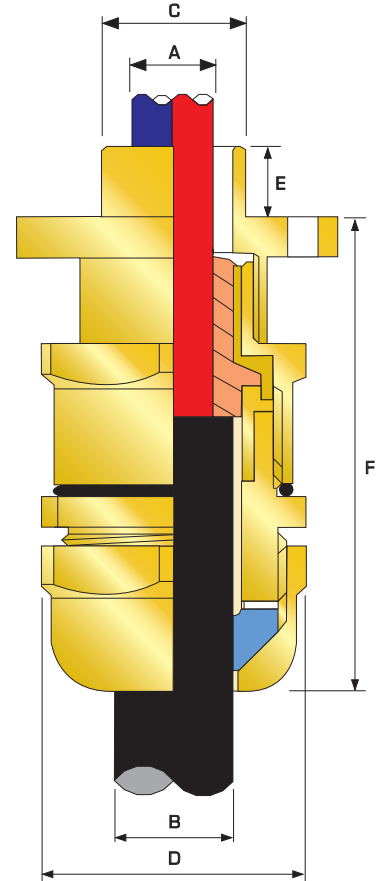

See page 136 for flange mounting dimensions

Cable Gland Selection Table

Cable Gland Size	Spigot Diameter 'C'	Minimum Spigot Length 'E'	Max. dia. Over Conductors & Max. No. of Cores		Overall Cable Diameter		Across Flats 'D'	Across Corners 'D'	Nominal Protrusion Length	Ordering Reference (Metric)	PVC Shroud Reference *	Cable Gland Weight (Kgs)
	Metric		Dia.	Cores	Min	Max	Max	Max				
20S	20.0	15.0	12.6	15	3.2	8.7	24.0	26.6	68.5	20SPXSS2K1RA/MF	PVC04	0.410
20	20.0	15.0	12.6	15	6.1	11.7	30.5	33.3	70.5	20PXSS2K1RA/MF	PVC04	0.460
25	25.0	15.0	17.5	29	11.1	20.0	37.5	40.5	77.5	25PXSS2K1RA/MF	PVC09	0.630
32	32.0	15.0	23.6	51	17.0	26.3	46.0	51.0	79.5	32PXSS2K1RA/MF	PVC09	0.860
40	40.0	15.0	30.0	80	31.0	38.2	55.0	61.0	88.0	40PXSS21RA/MF	PVC15	1.050
50S	50.0	15.0	36.6	122	35.6	44.1	60.0	66.5	85.5	50SPXSS2K1RA/MF	PVC18	1.170
50	50.0	15.0	41.0	149	41.5	50.0	70.0	78.6	90.5	50PXSS2K1RA/MF	PVC21	1.230
63S	63.0	15.0	47.9	205	47.2	56.0	75.0	83.2	101.5	63SPXSS2K1RA/MF	PVC23	1.380
63	63.0	15.0	53.7	259	54.0	62.0	80.0	89.0	102.0	63PXSS2K1RA/MF	PVC25	1.410
75S	75.0	15.0	59.8	320	61.1	68.0	89.0	101.6	109.0	75SPXSS2K1RA/MF	PVC28	1.900
75	75.0	15.0	64.3	364	66.6	79.4	99.0	111.1	112.0	75PXSS2K1RA/MF	PVC30	2.050

All dimensions in millimetres

Note: *LSF Shrouds also available on request. †Alternative armour clamping range available for non-standard armour sizes. Marine approvals including Lloyds, DNV & ABS are also available from CMP Products.

PX2KX/M CABLE GLAND

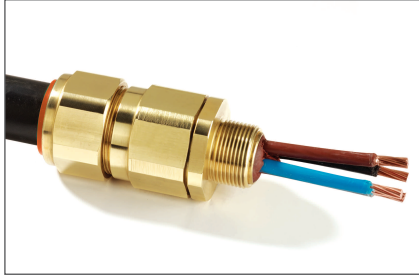

PX2KX/M Flameproof Cable Gland

CMP Type PX2KX/M Dual Certified Flameproof (Type 'd') and Increased Safety (Type 'e') cable gland for use in Zone 1, Zone 2, Zone 21 and Zone 22 Hazardous Areas with all types of Pliable Wire Armour cable providing a compound barrier seal around the conductors and an environmental seal on the cable outer sheath. The cable gland being suitable for use with armoured cables provides mechanical cable retention and electrical continuity via armour termination. A detachable armour cone and AnyWay universal clamping ring arrangement allows the cable to be easily disconnected from the equipment, for maintenance and change out etc, and re-connected with the same consummate ease. This feature also facilitates remote make off procedures when the termination is to be conducted in confined spaces or in areas of restricted access. The CMP PX2KX/M cable gland is suitable for use with all forms of equipment protection permitted in Zone 1, Zone 2, Zone 21 & Zone 22 provided always that the prevailing code of practice for selection, installation and maintenance is observed, e.g. IEC 60079-14.

TECHNICAL DATA

Type	PX2KX/M
Design Specification	EN 50262:1999, BS 6121:Part 1:1989
ATEX Certification	SIRA06ATEX1097X
Code of Protection Category	ATEX Ex IM2, Exd I / Exe I
Compliance Standards	EN 60079-0:2004, EN 60079-1: 2004, EN 60079-7: 2003
IECEX Approval Number	IECEX SIR 06.0044X
Code of Protection Category	Ex d IIC / Ex e II / Ex nR II / Ex tD A21 IP66
Compliance Standards	IEC 60079-0:2004, IEC 60079-1:2003, IEC 60079-7:2001
GOST R Certificate Number	POCC GB. ГБ05.В01913
Code of Protection Category	Ex d I U / Ex e I U
Compliance Standards	ГОСТ Р 51330.0-99, ГОСТ Р 51330.1-99, ГОСТ Р 51330.8-99, ГОСТ Р 52350.0-2005, ГОСТ Р 52350.1-2005, ГОСТ Р 52350.7-2005
GGTN Permit Number	PPC 00-18010
GOST K Certificate Number	KZ7500052.05.01.00063
RoK Permit for Use Number	08-067693
Continuous Operating Temperature	-60°C to +100°C
Ingress Protection Rating	IP66, IP67, IP68
Ingress Protection Document	5046 C549G
Deluge Protection Compliance	DTS01 : 91
Deluge Protection Document	5046 C549G-D
Cable Gland Material	Brass, Electroless Nickel Plated Brass, Stainless Steel
Seal Material	CMP SOLO LSF Thermoplastic Elastomer / Epoxy Resin Barrier Compound
Cable Type	Pliable Wire Armour
Armour Clamping	Detachable Armour Cone & AnyWay Universal Clamping Ring
Sealing Technique	Unique CMP "LRS"™ Outer Seal (Load Retention Seal)
Sealing Area(s)	Inner Compound Barrier & Cable Outer Sheath
Optional Accessories	Locknut, Serrated Washer, Entry Thread Seal, Earth Tag, Adaptor/ Reducer, Shroud

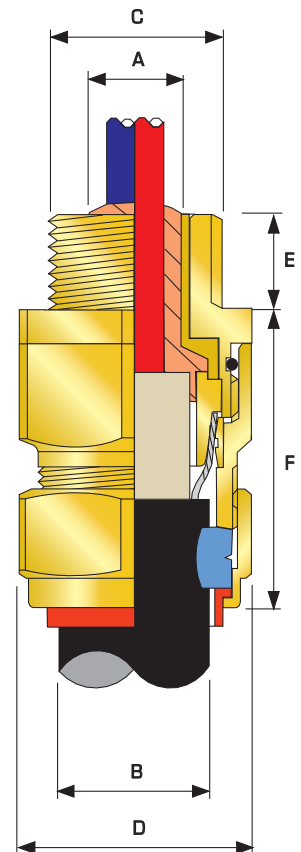

Cable Gland Selection Table

Cable Gland Size	Available Entry Threads 'C'			Minimum Thread Length 'E'	Max. dia. Over conductors & Max. No. of Cores 'A'		Overall Cable Diameter 'B'		Pliable Wire Armour		Across Flats 'D'	Across Corners 'D'	Nominal Protrusion Length 'F'	Ordering Reference (Brass Metric) #	PVC Shroud Reference*	Cable Gland Weight Kgs
	Standard	Option			Dia	Cores	Min	Max	Min	Max						
		Metric	NPT													
20S	M20	1/2"	3/4"	15.0	12.6	15	9.5	15.9	0.0	7/0.45	24.0	26.6	58.5	20SPX2KX1RA/M	PVC04	0.163
20	M20	1/2"	3/4"	15.0	12.6	15	12.5	20.9	0.0	7/0.45	30.5	33.3	60.5	20PX2KX1RA/M	PVC06	0.217
25S	M25	3/4"	1"	15.0	17.5	29	14.0	22.0	0.0	7/0.45	37.5	40.5	67.5	25SPX2KX1RA/M	PVC09	0.345
25	M25	3/4"	1"	15.0	17.5	29	18.2	26.2	0.0	7/0.45	37.5	40.5	67.5	25PX2KX1RA/M	PVC09	0.345
32	M32	1"	1-1/4"	15.0	23.6	51	23.7	33.9	0.0	7/0.45	46.0	51.0	69.5	32PX2KX1RA/M	PVC11	0.484
40	M40	1-1/4"	1-1/2"	15.0	30.0	80	27.9	40.4	0.0	7/0.71	55.0	61.0	78.0	40PX2KX1RA/M	PVC15	0.700
50S	M50	1-1/2"	2"	15.0	36.6	122	35.2	46.7	0.0	7/0.71	60.0	66.5	75.5	50SPX2KX1RA/M	PVC18	0.800
50	M50	2"	2-1/2"	15.0	41.0	149	40.4	53.1	0.9	7/0.71	70.0	78.6	80.5	50PX2KX1RA/M	PVC21	0.830
63S	M63	2"	2-1/2"	15.0	47.9	205	45.6	59.4	0.9	7/0.71	75.0	83.2	91.5	63SPX2KX1RA/M	PVC23	1.415
63	M63	2-1/2"	3"	15.0	53.7	259	54.6	65.9	0.9	7/0.71	80.0	89.0	92.0	63PX2KX1RA/M	PVC25	1.514
75S	M75	2-1/2"	3"	15.0	59.8	320	59.0	72.1	1.25	7/0.71	89.0	101.6	99.0	75SPX2KX1RA/M	PVC28	2.199
75	M75	3"	3-1/2"	15.0	64.3	364	66.7	78.5	1.25	7/0.71	99.0	111.1	102.0	75PX2KX1RA/M	PVC30	2.770

All dimensions in millimetres

Note: *LSF Shrouds also available on request. # Other thread forms are available

PX2KX/MF CABLE GLAND

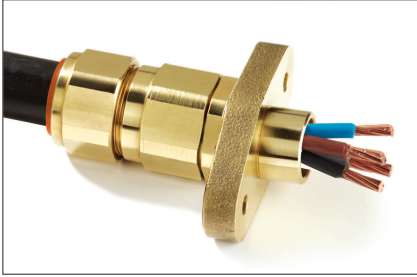

PX2KX/MF Flameproof Cable Gland

CMP Type PX2KX/MF Dual Certified Flameproof (Type 'd') and Increased Safety (Type 'e') cable gland for use in Zone 1, Zone 2, Zone 21 and Zone 22 Hazardous Areas with all types of Pliable Wire Armour cable providing a compound barrier seal around the conductors and an environmental seal on the cable outer sheath. The cable gland being suitable for use with armoured cables provides mechanical cable retention and electrical continuity via armour termination. A detachable armour cone and AnyWay universal clamping ring arrangement allows the cable to be easily disconnected from the equipment, for maintenance and change out etc, and re-connected with the same consummate ease. This feature also facilitates remote make off procedures when the termination is to be conducted in confined spaces or in areas of restricted access. The CMP PX2KX/MF cable gland is suitable for use with all forms of equipment protection permitted in Zone 1, Zone 2, Zone 21 & Zone 22 provided always that the prevailing code of practice for selection, installation and maintenance is observed, e.g. IEC 60079-14.

TECHNICAL DATA	
Type	PX2KX/MF
Design Specification	BS 6121: Part 1: 1989, EN 50262:1999
ATEX Certification	SIRA06ATEX1097X and SIRA02ATEX3421U
Code of Protection Category	ATEX Ex d I, Ex e I
Compliance Standards	EN 60079-0: 2006, EN 60079-1:2004, EN 60079-7: 2003
Continuous Operating Temperature	-60°C to +100°C
Ingress Protection Rating	IP66
Cable Gland Material	Brass, Electroless Nickel Plated Brass, Stainless Steel
Seal Material	CMP SOLO LSF Thermoplastic Elastomer / Epoxy Resin Barrier Compound
Cable Type	Pliable Wire Armour
Sealing Technique	CMP Inner Displacement Seal & Unique CMP "LRS"™ Outer Seal (Load Retention Seal)
Sealing Area(s)	Inner Compound Barrier & Cable Outer Sheath

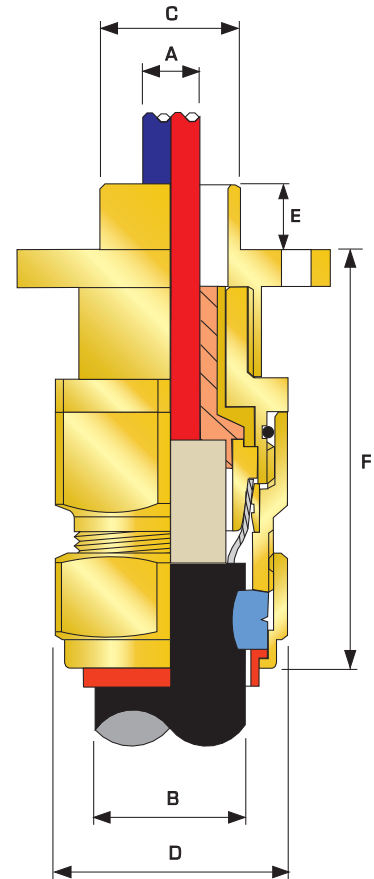

See page 136 for flange mounting dimensions

Cable Gland Selection Table

Cable Gland Size	Spigot Diameter 'C'	Minimum Spigot Length 'E'	Max. dia. Over conductors & Max. No. of Cores 'A'		Overall Cable Diameter 'B'		Pliable Wire Armour		Nominal Across Flats	Nominal Across Corners	Nominal Protrusion Length 'F'	Ordering Reference (Brass Metric) #	PVC Shroud Reference*	Cable Gland Weight Kgs
	Metric		Dia	Cores	Min	Max	Min	Max						
20S	20.0	15.0	12.6	15	9.5	15.9	0.0	7/0.45	24.0	26.6	58.5	20SPX2KX1RA/MF	PVC04	0.163
20	20.0	15.0	12.6	15	12.5	20.9	0.0	7/0.45	30.5	33.3	60.5	20PX2KX1RA/MF	PVC06	0.217
25S	25.0	15.0	17.5	29	14.0	22.0	0.0	7/0.45	37.5	40.5	67.5	25SPX2KX1RA/MF	PVC09	0.345
25	25.0	15.0	17.5	29	18.2	26.2	0.0	7/0.45	37.5	40.5	67.5	25PX2KX1RA/MF	PVC09	0.345
32	32.0	15.0	23.6	51	23.7	33.9	0.0	7/0.45	46.0	51.0	69.5	32PX2KX1RA/MF	PVC11	0.484
40	40.0	15.0	30.0	80	27.9	40.4	0.0	7/0.71	55.0	61.0	78.0	40PX2KX1RA/MF	PVC15	0.700
50S	50.0	15.0	36.6	122	35.2	46.7	0.0	7/0.71	60.0	66.5	75.5	50SPX2KX1RA/MF	PVC18	0.800
50	50.0	15.0	41.0	149	40.4	53.1	0.9	7/0.71	70.0	78.6	80.5	50PX2KX1RA/MF	PVC21	0.830
63S	63.0	15.0	47.9	205	45.6	59.4	0.9	7/0.71	75.0	83.2	91.5	63SPX2KX1RA/MF	PVC23	1.415
63	63.0	15.0	53.7	259	54.6	65.9	0.9	7/0.71	80.0	89.0	92.0	63PX2KX1RA/MF	PVC25	1.514
75S	75.0	15.0	59.8	320	59.0	72.1	1.25	7/0.71	89.0	101.6	99.0	75SPX2KX1RA/MF	PVC28	2.199
75	75.0	15.0	64.3	364	66.7	78.5	1.25	7/0.71	99.0	111.1	102.0	75PX2KX1RA/MF	PVC30	2.770

All dimensions in millimetres

Note: *LSF Shrouds also available on request. # Other thread forms are available

PX2KW/M CABLE GLAND

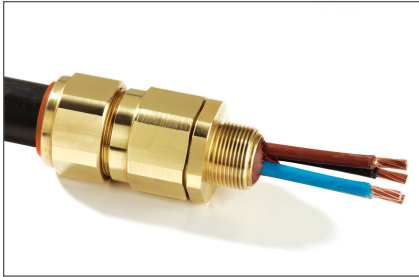

PX2KW/M Flameproof Cable Gland

CMP Type PX2KW/M Dual Certified Flameproof (Type 'd') and Increased Safety (Type 'e') cable gland for use in Zone 1, Zone 2, Zone 21 and Zone 22 Hazardous Areas with all types of Single Wire Armour cable providing a compound barrier seal around the conductors and an environmental seal on the cable outer sheath. The cable gland being suitable for use with armoured cables provides mechanical cable retention and electrical continuity via armour termination. A detachable armour cone and AnyWay universal clamping ring arrangement allows the cable to be easily disconnected from the equipment, for maintenance and change out etc, and re-connected with the same consummate ease. This feature also facilitates remote make off procedures when the termination is to be conducted in confined spaces or in areas of restricted access. The CMP PX2KW/M cable gland is suitable for use with all forms of equipment protection permitted in Zone 1, Zone 2, Zone 21 & Zone 22 provided always that the prevailing code of practice for selection, installation and maintenance is observed, e.g. IEC 60079-14.

TECHNICAL DATA

Type	PX2KW/M
Design Specification	EN 50262:1999, BS 6121:Part 1:1989
ATEX Certification	SIRA06ATEX1097X
Code of Protection Category	ATEX IM2, Exd I / Exe I
Compliance Standards	EN 60079-0:2004, EN 60079-1: 2004, EN 60079-7: 2003
IECEX Approval Number	IECEX SIR 06.0044X
Code of Protection Category	Ex d IIC / Ex e II / Ex nR II / Ex tD A21 IP66
Compliance Standards	IEC 60079-0:2004, IEC 60079-1:2003, IEC 60079-7:2001
GOST R Certificate Number	POCC GB. ГБ05.В01913
Code of Protection Category	Ex d I U / Ex e I U
Compliance Standards	ГОСТ Р 51330.0-99, ГОСТ Р 51330.1-99, ГОСТ Р 51330.8-99, ГОСТ Р 52350.0-2005, ГОСТ Р 52350.1-2005, ГОСТ Р 52350.7-2005
GGTN Permit Number	PPC 00-18010
GOST K Certificate Number	KZ7500052.05.01.00063
RoK Permit for Use Number	08-067693
Continuous Operating Temperature	-60°C to +100°C
Ingress Protection Rating	IP66, IP67, IP68
Ingress Protection Document	5046 C549G
Deluge Protection Compliance	DTS01 : 91
Deluge Protection Document	5046 C549G-D
Cable Gland Material	Brass, Electroless Nickel Plated Brass, Stainless Steel
Seal Material	CMP SOLO LSF Thermoplastic Elastomer / Epoxy Resin Barrier Compound
Cable Type	Single Wire Armour
Armour Clamping	Detachable Armour Cone & AnyWay Universal Clamping Ring
Sealing Technique	Unique CMP "LRS"™ Outer Seal (Load Retention Seal)
Sealing Area(s)	Inner Compound Barrier & Cable Outer Sheath
Optional Accessories	Locknut, Serrated Washer, Entry Thread Seal, Earth Tag, Adaptor/ Reducer, Shroud

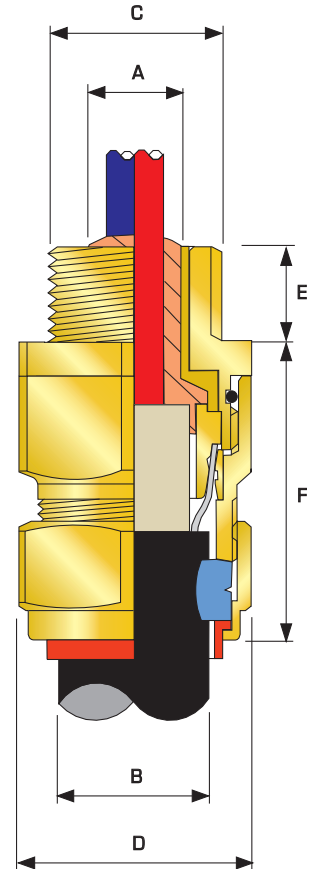

Cable Gland Selection Table

Cable Gland Size	Available Entry Threads 'C'			Thread Length 'E'	Max. dia. Over conductors & Max. No. of Cores 'A'		Overall Cable Diameter 'B'		Standard Armour Range †		Across Flats 'D'	Across Corners 'D'	Nominal Protrusion Length 'F'	Ordering Reference (Brass Metric) #	PVC Shroud Reference*	Cable Gland Weight (Kgs)
	Standard	Option			Dia	Cores	Min	Max	Min	Max						
		Metric	NPT													
20S	M20	1/2"	3/4"	15.0	12.6	15	9.5	15.9	0.90	1.25	24.0	26.6	58.5	20SPX2KW1RA/M	PVC04	0.163
20	M20	1/2"	3/4"	15.0	12.6	15	12.5	20.9	0.90	1.25	30.5	33.3	60.5	20PX2KW1RA/M	PVC06	0.217
25S	M25	3/4"	1"	15.0	17.5	29	14.0	22.0	1.25	1.60	37.5	40.5	67.5	25SPX2KW1RA/M	PVC09	0.345
25	M25	3/4"	1"	15.0	17.5	29	18.2	26.2	1.25	1.60	37.5	40.5	67.5	25PX2KW1RA/M	PVC09	0.345
32	M32	1"	1-1/4"	15.0	23.6	51	23.7	33.9	1.60	2.00	46.0	51.0	69.5	32PX2KW1RA/M	PVC11	0.484
40	M40	1-1/4"	1-1/2"	15.0	30.0	80	27.9	40.4	1.60	2.00	55.0	61.0	78.0	40PX2KW1RA/M	PVC15	0.700
50S	M50	1-1/2"	2"	15.0	36.6	122	35.2	46.7	2.00	2.50	60.0	66.5	75.5	50SPX2KW1RA/M	PVC18	0.800
50	M50	2"	2-1/2"	15.0	41.0	149	40.4	53.1	2.00	2.50	70.0	78.6	80.5	50PX2KW1RA/M	PVC21	0.830
63S	M63	2"	2-1/2"	15.0	47.9	205	45.6	59.4	2.00	2.50	75.0	83.2	91.5	63SPX2KW1RA/M	PVC23	1.415
63	M63	2-1/2"	3"	15.0	53.7	259	54.6	65.9	2.00	2.50	80.0	89.0	92.0	63PX2KW1RA/M	PVC25	1.514
75S	M75	2-1/2"	3"	15.0	59.8	320	59.0	72.1	2.00	2.50	89.0	101.6	99.0	75SPX2KW1RA/M	PVC28	2.199
75	M75	3"	3-1/2"	15.0	64.3	364	66.7	78.5	2.00	2.50	99.0	111.1	102.0	75PX2KW1RA/M	PVC30	2.770

All dimensions in millimetres

Note: *LSF Shrouds also available on request. # Other thread forms are available

PX2KW/MF CABLE GLAND

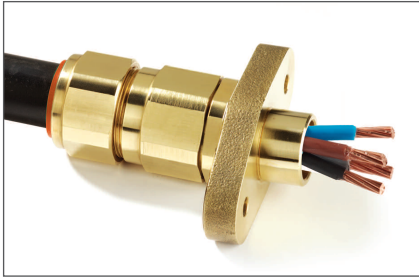

PX2KW/MF Flameproof Cable Gland

CMP Type PX2KW/MF Dual Certified Flameproof (Type 'd') and Increased Safety (Type 'e') cable gland for use in Zone 1, Zone 2, Zone 21 and Zone 22 Hazardous Areas with all types of Single Wire Armour cable providing a compound barrier seal around the conductors and an environmental seal on the cable outer sheath. The cable gland being suitable for use with armoured cables provides mechanical cable retention and electrical continuity via armour termination. A detachable armour cone and AnyWay universal clamping ring arrangement allows the cable to be easily disconnected from the equipment, for maintenance and change out etc, and re-connected with the same consummate ease. This feature also facilitates remote make off procedures when the termination is to be conducted in confined spaces or in areas of restricted access. The CMP PX2KW/MF cable gland is suitable for use with all forms of equipment protection permitted in Zone 1, Zone 2, Zone 21 & Zone 22 provided always that the prevailing code of practice for selection, installation and maintenance is observed, e.g. IEC 60079-14.

TECHNICAL DATA	
Type	PX2KW/MF
Design Specification	EN 50262, BS 6121:Part 1:1989
ATEX Certification	SIRA06ATEX1097X
Code of Protection Category	ATEX $\text{Ex} \text{II} \text{GD} \text{d} \text{IIC}$, $\text{Ex} \text{e} \text{II}$, $\text{Ex} \text{tD} \text{A21} \text{IP66}$, $\text{Ex} \text{nR} \text{II}$, Equipment Zone 1, Zone 2, Zone 21, & Zone 22 - Gas Groups IIA, IIB, IIC
Compliance Standards	EN 60079-0: 2006, EN 60079-1: 2004, EN 60079-7: 2003
IECEX Approval Number	IECEX SIR 06.0044X
Code of Protection Category	$\text{Ex} \text{d} \text{IIC} / \text{Ex} \text{e} \text{II} / \text{Ex} \text{nR} / \text{Ex} \text{tD} \text{A21} \text{IP66/IP67/IP68}$
Compliance Standards	IEC 60079-0:2004, IEC 60079-1:2003, IEC 60079-7:2001
GOST R Certificate Number	POCC GB. ГЕ05.В01912
Code of Protection Category	$\text{Ex} \text{d} \text{IIC} \text{U} / \text{Ex} \text{e} \text{II} \text{U}$
Compliance Standards	ГОСТ Р 51330.0-99, ГОСТ Р 51330.1-99, ГОСТ Р 51330.8-99, ГОСТ Р 52350.0-2005, ГОСТ Р 52350.1-2005, ГОСТ Р 52350.7-2005
GGTN Permit Number	PPC 00-18262
RoK Permit for Use Number	08-067693
Lloyds Approval Number	01/00172
DNV Approval Number	E-6157
ABS Approval Number	01-LD 234401-PDA
Continuous Operating Temperature	-60°C to +100°C
Ingress Protection Rating	IP66, IP67, IP68
Ingress Protection Document	5046 C549G
Deluge Protection Compliance	DTS01 : 91
Deluge Protection Document	5046 C549G-D
NEMA Rating	NEMA 4X
Cable Gland Material	Brass, Electroless Nickel Plated Brass, Stainless Steel
Seal Material	CMP SOLO LSF Thermoplastic Elastomer / Epoxy Resin Barrier Compound
Cable Type	Pliable Wire Armour
Armour Clamping	Detachable Armour Cone & AnyWay Universal Clamping Ring
Sealing Technique	Unique CMP "LRS"™ Outer Seal (Load Retention Seal)
Sealing Area(s)	Inner Compound Barrier & Cable Outer Sheath
Optional Accessories	Locknut, Serrated Washer, Entry Thread Seal, Earth Tag, Adaptor/ Reducer, Shroud

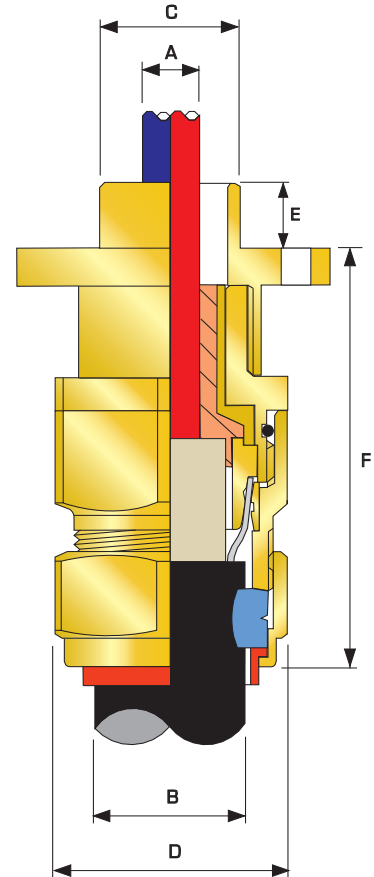

See page 136 for flange mounting dimensions

Cable Gland Selection Table

Cable Gland Size	Spigot Diameter 'C'	Minimum Spigot Length 'E'	Max. dia. Over conductors & Max. No. of Cores 'A'		Overall Cable Diameter 'B'		Standard Armour Range †		Across Flats 'D'	Across Corners 'D'	Nominal Protrusion Length 'F'	Ordering Reference (Brass Metric)	PVC Shroud Reference*	Cable Gland Weight (Kgs)
	Metric		Dia	Cores	Min	Max	Min	Max						
20S	20.0	15.0	12.6	15	9.5	15.9	0.90	1.25	24.0	26.6	68.5	20SPX2KW1RA/MF	PVC04	0.360
20	20.0	15.0	12.6	15	12.5	20.9	0.90	1.25	30.5	33.3	70.5	20PX2KW1RA/MF	PVC06	0.420
25S	25.0	15.0	17.5	29	14.0	22.0	1.25	1.60	37.5	40.5	77.5	25SPX2KW1RA/MF	PVC09	0.570
25	25.0	15.0	17.5	29	18.2	26.2	1.25	1.60	37.5	40.5	77.5	25PX2KW1RA/MF	PVC09	0.570
32	32.0	15.0	23.6	51	23.7	33.9	1.60	2.00	46.0	51.0	79.5	32PX2KW1RA/MF	PVC11	0.790
40	40.0	15.0	30.0	80	27.9	40.4	1.60	2.00	55.0	61.0	88.0	40PX2KW1RA/MF	PVC15	1.150
50S	50.0	15.0	36.6	122	35.2	46.7	2.00	2.50	60.0	66.5	85.5	50SPX2KW1RA/MF	PVC18	1.370
50	50.0	15.0	41.0	149	40.4	53.1	2.00	2.50	70.0	78.6	90.5	50PX2KW1RA/MF	PVC21	1.430
63S	63.0	15.0	47.9	205	45.6	59.4	2.00	2.50	75.0	83.2	101.5	63SPX2KW1RA/MF	PVC23	2.090
63	63.0	15.0	53.7	259	54.6	65.9	2.00	2.50	80.0	89.0	101.5	63PX2KW1RA/MF	PVC25	2.290
75S	75.0	15.0	59.8	320	59.0	72.1	2.00	2.50	89.0	101.6	109.0	75SPX2KW1RA/MF	PVC28	2.950
75	75.0	15.0	64.3	364	66.7	78.5	2.00	2.50	99.0	111.1	112.0	75PX2KW1RA/MF	PVC30	3.520

All dimensions in millimetres

Note: *LSF Shrouds also available on request. # Other thread forms are available



NORTH AMERICAN SPECIFICATION CONNECTORS

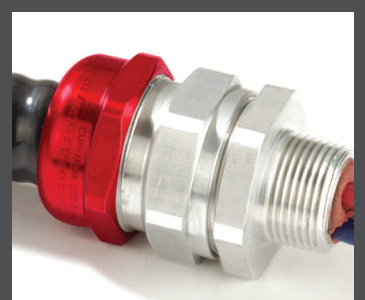
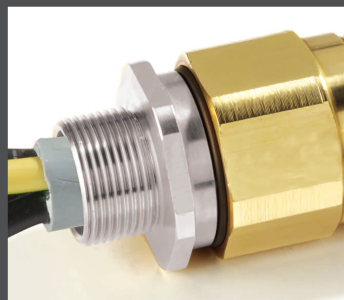
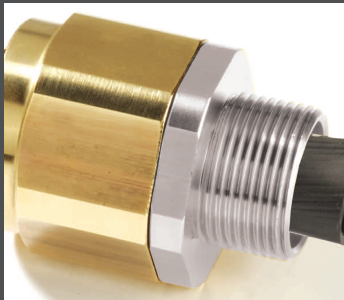



■ APPLICATION

The CMP range of Cable Connectors & Cable Glands for Hazardous and Wet Locations are versatile enough to meet virtually all situations where flexible and non flexible cables are used instead of pipe conduit systems. Designed for both offshore and onshore requirements the options available cover Armoured, Armored & Jacketed and Non-Armored (e.g. IEEE45) Types and also Interlocked or Corrugated Continuously Welded MC (or MC-HL), and Teck cables.

■ PRODUCTS

Solutions for virtually all-conceivable cables permitted for use in hazardous locations when installed in both Class / Divisions and Class / Zones classification concepts.

■ SPECIFICATIONS & APPROVALS

CMP Hazardous Location Cable Connectors comply with prevailing UL, ISA & ANSI Standards and meet the requirements of NEC and CEC installation code requirements. In addition product compliance with ABS and US Coast Guards USCG14CFR requirements is also offered.



BX2KX CABLE CONNECTOR

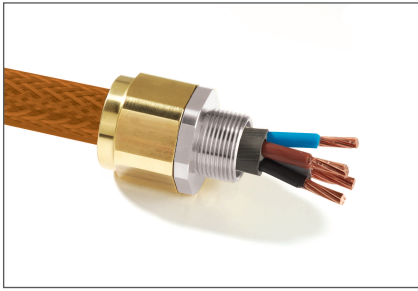

B2KX Ordinary Location Cable Connector

CMP B2KX Cable Connector suitable for use with Bronze Wire Armor non-jacketed cables in ordinary locations but may also be used in Class I Div 2 areas when installed in compliance with the NEC requirements. The cable connector provides mechanical retention and electrical continuity via the armor termination and is available in NPT (standard) or Metric thread forms. Standard material is Brass grade CuZn39Pb3 (CW614N) to EN12168 with Electroless Nickel Plated Brass entry component.

TECHNICAL DATA	
Type	B2KX
Design Specification	UL 514B
UL Listing File Number	UBWE.E200163
Code of Protection Category	Ordinary Locations
Compliance Standards	UL 514B
GOST K Certificate Number	KZ7500052.05.01.00063
RoK Permit for Use Number	08-067693
Lloyds Approval Number	01/00171
ABS Approval Number	01-LD 234401-PDA
Continuous Operating Temperature	-60°C to +150°C
Standard Connector Material	Brass With Nickel Plated Entry Component
Alternative Connector Material	Stainless Steel, Aluminium
Cable Type	Wire Braid Armor
Armor Clamping	Detachable Armor Cone & AnyWay Universal Clamping Ring
Optional Accessories	Locknut, Entry Thread Seal, Serrated Washer, Earth Tag, Adaptor/Reducer

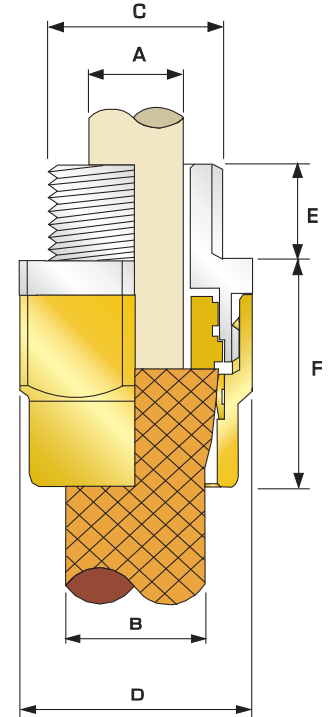

Cable Connector Selection Table



Cable Connector Size	Available Entry Threads 'C'			Minimum Thread Length 'E'		Cable Bedding Diameter 'A'	Overall Cable Diameter 'B'	Armour Range		Across Flats 'D'	Across Corners 'D'	Nominal Protrusion Length 'F'	Ordering Reference (NPT)	PVC Shroud Reference *	Cable Connector Weight (Ozs)
	Standard	Option		NPT	Metric	Max	Max	Min	Max	Max	Max				
		NPT	Metric												
20S	1/2"	3/4"	M20	0.630	0.591	0.461	0.626	0.0	0.039	0.945	1.047	2.303	20SB2KX1RA731	PVC04	4.05
20	1/2"	3/4"	M20	0.630	0.591	0.551	0.823	0.0	0.039	1.201	1.311	2.382	20B2KX1RA731	PVC06	5.29
25	3/4"	1"	M25	0.669	0.591	0.787	1.031	0.0	0.039	1.476	1.594	2.657	25B2KX1RA732	PVC09	7.05
32	1"	1-1/4"	M32	0.787	0.591	1.035	1.335	0.0	0.039	1.811	2.008	2.736	32B2KX1RA733	PVC11	10.57
40	1-1/4"	1-1/2"	M40	0.787	0.591	1.268	1.591	0.0	0.039	2.165	2.402	3.071	40B2KX1RA734	PVC15	13.39
50S	1-1/2"	2"	M50	0.787	0.591	1.504	1.839	0.0	0.039	2.362	2.618	2.972	50SB2KX1RA735	PVC18	14.80
50	2"	2-1/2"	M50	0.906	0.591	1.736	2.091	0.0	0.039	2.756	3.094	3.169	50B2KX1RA736	PVC21	19.74
63S	2"	2-1/2"	M63	0.906	0.591	1.969	2.339	0.0	0.039	2.953	3.276	3.602	63SB2KX1RA736	PVC23	22.91
63	2-1/2"	3"	M63	0.984	0.591	2.205	2.594	0.0	0.039	3.150	3.504	3.622	63B2KX1RA737	PVC25	24.67
75S	2-1/2"	3"	M75	0.984	0.591	2.441	2.839	0.0	0.039	3.504	4.000	3.898	75SB2KX1RA737	PVC28	29.96
75	3"	3-1/2"	M75	1.417	0.591	2.677	3.091	0.0	0.039	3.898	4.374	4.016	75B2KX1RA738	PVC30	37.00
90	4"	4"	M90	1.417	0.591	3.150	3.559	0.0	0.063	4.488	5.063	4.724	90B2KX1RA739	PVC32	42.29

All dimensions in inches

Note: *LSF Shrouds also available on request. Marine approvals including Lloyds, DNV & ABS are also available from CMP Products.

C2KX CABLE CONNECTOR

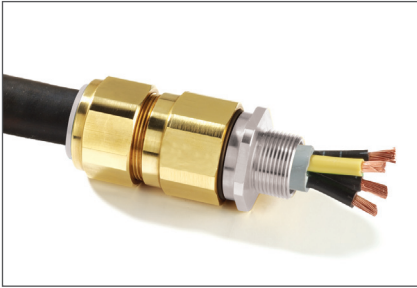

C2KX Ordinary, Wet & Hazardous Location Cable Connector

CMP C2KX Cable Connector suitable for use with Armored & Jacketed cables incorporating Wire Braid Armor in Ordinary, Wet & Hazardous Locations. The cable connector provides mechanical retention and electrical continuity via the armor termination and is available in NPT (standard) or Metric thread forms. Standard material is Brass grade CuZn39Pb3 (CW614N) to EN12168 with Electroless Nickel Plated Brass entry component. This product provides Nema 4X and IP68 ingress protection and is UL listed for use in Class I Zone I AEx e II applications and can be used in Class I Division 2 areas when installed in compliance with the NEC requirements.

TECHNICAL DATA	
Type	C2KX
Design Specification	UL 514B, EN 50262:1999
UL Listing File Number	UBWE.E200163, FDJR.E256367
Code of Protection Category	Ordinary & Wet Locations, Class I, Div 2, *ABCD, Class I, Zone 1, AEx e II, Class I, Zone 2, AEx e II (*When installed in compliance with the NEC)
Compliance Standards	UL 514B, ANSI / UL 60079-0, ANSI / UL 60079-7
Lloyds Approval Number	01/00171
GOST K Certificate Number	KZ7500052.05.01.00063
RoK Permit for Use Number	08-067693
DNV Approval Number	E-6157
ABS Approval Number	01-LD 234401-PDA
Continuous Operating Temperature	-60°C to +130°C
Ingress Protection Rating	IP66, IP67, IP68
Ingress Protection Document	5046 C549G
Deluge Protection Compliance	DTS01 : 91
Code of Protection Category	5046 C549G-D
NEMA Rating	NEMA 4X
Standard Connector Material	Brass With Nickel Plated Entry Component
Alternative Connector Material	Brass, Nickel Plated Brass, Stainless Steel
Seal Material	CMP SOLO LSF Thermoplastic Elastomer
Cable Type	Armored & Jacketed
Armour Clamping	Detachable Armour Cone & AnyWay Universal Clamping Ring
Sealing Technique	Unique CMP "LRS"™ Outer Seal (Load Retention Seal)
Sealing Area(s)	Cable Outer Jacket
Optional Accessories	Locknut, Shroud, Entry Thread Seal, Serrated Washer, Earth Tag, Adaptor/Reducer

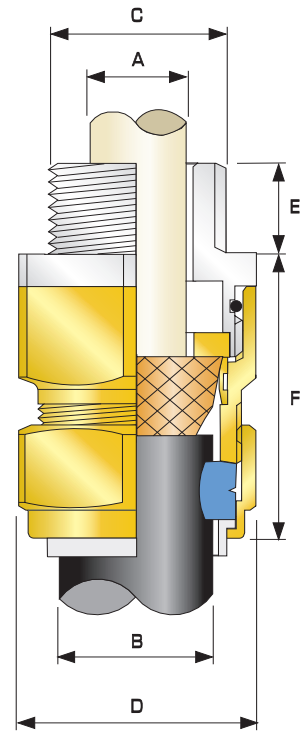

Cable Connector Selection Table

Cable Connector Size	Available Entry Threads 'C'			Minimum Thread Length 'E'		Cable Bedding Diameter 'A'	Overall Cable Diameter 'B'			Armour Range		Across Flats 'D'	Across Corners 'D'	Nominal Protrusion Length 'F'	Ordering Reference (NPT)	PVC Shroud Reference *	Cable Connector Weight (Ozs)
	Standard	Option					NPT	Metric	Min	Max	Min						
		NPT	NPT	Metric	NPT	Metric						Max	Max	Max	Max		
20S/16	1/2"	3/4"	M20	0.630	0.591	0.461	0.240	0.453	0.0	0.039	0.945	1.047	2.303	20S16C2KX1RA731	PVC04	4.65	
20S	1/2"	3/4"	M20	0.630	0.591	0.461	0.374	0.626	0.0	0.039	0.945	1.047	2.303	20SC2KX1RA731	PVC04	4.65	
20	1/2"	3/4"	M20	0.630	0.591	0.551	0.492	0.823	0.0	0.039	1.201	1.311	2.382	20C2KX1RA731	PVC06	6.84	
25S	3/4"	1"	M25	0.669	0.591	0.787	0.551	0.866	0.0	0.039	1.476	1.594	2.657	25C2KX1RA732	PVC09	10.78	
25	3/4"	1"	M25	0.669	0.591	0.787	0.717	1.031	0.0	0.039	1.476	1.594	2.657	25C2KX1RA732	PVC09	10.78	
32	1"	1-1/4"	M32	0.787	0.591	1.035	0.933	1.335	0.0	0.039	1.811	2.008	2.736	32C2KX1RA733	PVC11	16.49	
40	1-1/4"	1-1/2"	M40	0.787	0.591	1.268	1.098	1.591	0.0	0.039	2.165	2.402	3.071	40C2KX1RA734	PVC15	23.89	
50S	1-1/2"	2"	M50	0.787	0.591	1.504	1.386	1.839	0.0	0.039	2.362	2.618	2.972	50SC2KX1RA735	PVC18	26.43	
50	2"	2-1/2"	M50	0.906	0.591	1.736	1.591	2.091	0.0	0.039	2.756	3.094	3.169	50SC2KX1RA736	PVC21	36.79	
63S	2"	2-1/2"	M63	0.906	0.591	1.969	1.795	2.339	0.0	0.039	2.953	3.276	3.602	63SC2KX1RA736	PVC23	37.85	
63	2-1/2"	3"	M63	0.984	0.591	2.205	2.150	2.594	0.0	0.039	3.150	3.504	3.622	63C2KX1RA737	PVC25	45.11	
75S	2-1/2"	3"	M75	0.984	0.591	2.441	2.323	2.839	0.0	0.039	3.504	4.000	3.898	75SC2KX1RA737	PVC28	65.55	
75	3"	3-1/2"	M75	1.417	0.591	2.677	2.626	3.091	0.0	0.039	3.898	4.374	4.016	75C2KX1RA738	PVC30	89.87	
90	3-1/2"	4"	M90	1.417	0.591	3.150	3.000	3.559	0.0	0.063	4.488	5.063	4.724	90C2KX1RA739	PVC32	128.63	

All dimensions in inches

Note: *LSF Shrouds also available on request. Marine approvals including Lloyds, DNV & ABS are also available from CMP Products.



D3CDS CABLE CONNECTOR

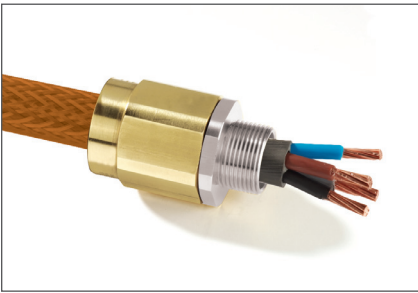

D3CDS Ordinary, Wet & Hazardous Location Cable Connector

CMP D3CDS Type Cable Connector for use all types of with Wire Braid Armored Marine cables in Ordinary, Wet & Hazardous Locations, providing a seal on the cable inner bedding. This product utilises a unique Compensating Displacement Seal (CDS) system which provides full compatibility with Restricted Breathing equipment. The cable gland provides mechanical cable retention and electrical continuity via armor wire termination. A reversible armour cone and AnyWay universal clamping ring arrangement allows the cable to be easily disconnected from the equipment, for maintenance and change out etc. This feature also facilitates remote make off procedures when the termination is to be conducted in confined spaces or in areas of restricted access. Separate tightening actions for the inner Compensating Displacement Seal (CDS) system and the armor termination affords maximum control over the pressure applied to the cable inner bedding. The D3CDS cable connector is available in NPT (standard) or Metric thread forms and the standard material is Brass grade CuZn39Pb3 (CW614N) to EN12168 with Electroless Nickel Plated Brass entry component. This product provides Nema 4X and IP68 ingress protection and is UL listed for use in Class I Zone I AEx e II applications and can be used in Class I Division 2 areas when installed in compliance with the NEC requirements.

TECHNICAL DATA	
Type	D3CDS
Design Specification	BS 6121:Part 1:1989, EN 50262:1999, UL 514B
ATEX Certification	SIRA06ATEX1283X
Code of Protection Category	ATEX (E) II 2/3 GD Ex d IIC, Ex e II, Ex nR II, Ex tD A21 IP66, Equipment Zone 1, Zone 2, Zone 21, & Zone 22 - Gas Groups IIA, IIB, IIC
Compliance Standards	EN 60079-0:2006, EN 60079-1:2004, EN 60079-7:2003, EN 60079-15:2005, EN 61241-0:2004, EN 61241-1:2004
IECEX Approval Number	IECEX SIR 07.005X
Code of Protection Category	Ex d IIC, Ex e II, Ex nR, Ex tD A21 IP66
Compliance Standards	IEC 60079-0:2004, IEC 60079-1:2003, IEC 60079-7:2006, IEC 60079-15:2005, IEC 61241-0:2004, IEC 61241-1:2004
CSA Certification	1310517
Code of Protection Category	Class I, II, III, Class I Div 2 Groups ABCD, Class II Div 2 Groups EFG, Enclosure Type 3, 4 and 4X, Class III, Ex d IIC, Ex e II
Compliance Standards	CSA C22.2 No. 174-M1984, CSA C22.2 No. 25-1966, CAN/CSA-C22.2 No. 18-92, CAN/CSA-C22.2 No. 94-M91, CAN/CSA-E60079-0-2001, IEC 60079-0 1998, CAN/CSA-E79-7-95
UL Listing File Number	UBWE.E200163, CYMJ.E256366, FDJR.E256367
Code of Protection Category	Ordinary & Wet Locations, Class I, Zone 1, AEx e II, Class I, Zone 2, AEx e II
Compliance Standards	UL 514B, ANSI / UL 60079-0, ANSI / UL 60079-7 to UL 514B, UL 60079-0, UL 60079-7
Gost R Certificate	POCC GB. ГБ 05.Б01912
Code of Protection Category	Ex d IIC U / Ex e II U
Compliance Standards	ГОСТ P 52350.0-2005, ГОСТ P 52350.1-2005, ГОСТ P 52350.7-2005
GGTN Permit Number	PPC 00-18262
GOST K Certificate	KZ7500052.05.01.00063
RoK Permit for Use Number	08-067693
Lloyds Approval Number	01/00172
DNV Approval Number	E-6157
ABS Approval Number	01-LD 234401-PDA
Continuous Operating Temperature	-60°C to +130°C
Ingress Protection Rating	IP66
Deluge Protection Compliance	DTS01:91
Deluge Protection Document	ITS 01005029 - D
Standard Cable Connector Material	Brass with Electroless Nickel Plated Brass Entry Component
Seal Material	CMP SOLO LSF Thermoplastic Elastomer
Cable Type	Wire Braid Armor, Armored & Jacketed, Served (Single) Wire Armor (SWA)
Armour Clamping	Reversible Armour Cone & AnyWay Universal Clamping Ring
Sealing Technique	CMP Inner CDS System
Sealing Area(s)	Cable Inner Bedding
Optional Accessories	Locknut, Shroud, Entry Thread Seal, Serrated Washer, Earth Tag, Adaptor/Reducer

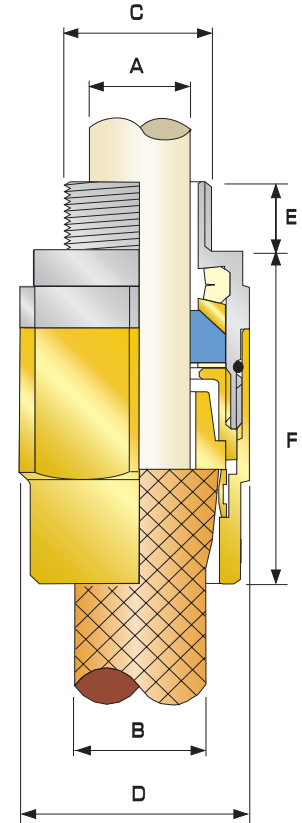

Note: Versions with dedicated armour cones, Type D3CDSW - for SWA cables only, and Type D3CDSX for all other approved cable types also available

Note: Stepped Cone is suitable for SWA cables, Grooved Cone is suitable for all other approved armoured cables

Cable Connector Selection Table

Cable Connector Size	Available Entry Threads 'C'			Minimum Thread Length 'E'		Cable Bedding Diameter 'A'		Overall Cable Diameter 'B'	Armour Range †				Across Flats 'D'	Across Corners 'D'	Nominal Protrusion Length 'F'	Ordering Reference (NPT) #	Cable Gland Weight (Ozs)
	Standard		Option	NPT	Metric	Min	Max		Grooved Cone		Stepped Cone						
	NPT	NPT	Metric	NPT	Metric	Min	Max	Min	Max	Min	Max	Max	Max				
20S/16	1/2"	3/4"	M20	0.630	0.591	0.122	0.343	0.453	0.000	0.039	0.035	0.039	0.945	1.047	2.362	20S16D3CDS1RA731	5.25
20S	1/2"	3/4"	M20	0.630	0.591	0.240	0.461	0.626	0.000	0.039	0.035	0.049	0.945	1.047	2.362	20SD3CDS1RA731	5.25
20	1/2"	3/4"	M20	0.630	0.591	0.256	0.551	0.823	0.000	0.039	0.035	0.049	1.201	1.311	2.441	20D3CDS1RA731	8.25
25S	3/4"	1"	M25	0.669	0.591	0.437	0.787	0.866	0.000	0.039	0.049	0.063	1.476	1.594	2.835	25SD3CDS1RA732	12.55
25	3/4"	1"	M25	0.669	0.591	0.437	0.787	1.031	0.000	0.039	0.049	0.063	1.476	1.594	2.835	25D3CDS1RA732	12.55
32	1"	1-1/4"	M32	0.787	0.591	0.669	1.035	1.335	0.000	0.039	0.063	0.079	1.811	2.008	2.953	32D3CDS1RA733	17.88
40	1-1/4"	1-1/2"	M40	0.787	0.591	0.866	1.268	1.591	0.000	0.039	0.063	0.079	2.165	2.402	2.992	40D3CDS1RA734	28.85
50S	1-1/2"	2"	M50	0.787	0.591	1.161	1.504	1.839	0.000	0.039	0.079	0.098	2.362	2.618	3.465	50SD3CDS1RA735	36.14
50	2"	2-1/2"	M50	0.906	0.591	1.402	1.736	2.091	0.000	0.039	0.079	0.098	2.756	3.189	3.543	50D3CDS1RA736	52.54
63S	2"	2-1/2"	M63	0.906	0.591	1.579	1.969	2.339	0.000	0.039	0.079	0.098	2.953	3.276	3.858	63SD3CDS1RA736	58.60
63	2-1/2"	3"	M63	0.984	0.591	1.858	2.205	2.594	0.000	0.039	0.079	0.098	3.150	3.504	3.858	63D3CDS1RA737	56.86
75S	2-1/2"	3"	M75	0.984	0.591	2.079	2.441	2.839	0.000	0.039	0.079	0.098	3.504	4.000	3.950	75SD3CDS1RA737	79.54
75	3"	3-1/2"	M75	1.417	0.591	2.327	2.677	3.091	0.000	0.039	0.079	0.098	3.898	4.374	4.094	75D3CDS1RA738	108.00
90	3-1/2"	4"	M90	1.417	0.591	2.622	3.126	3.559	0.000	0.063	0.124	0.124	4.488	5.063	5.118	90D3CDS1RA739	175.50

All dimensions in inches

Note: †Alternative armor clamping range available for non-standard armour sizes. Marine approvals including Lloyds, DNV & ABS are also available from CMP Products. # Other thread forms are available.

T3CDS CABLE CONNECTOR

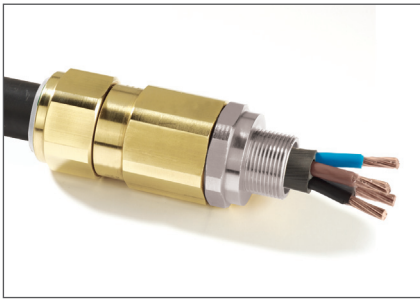

Triton CDS (T3CDS) Ordinary, Wet & Hazardous Location Cable Connector

CMP Triton CDS (T3CDS) Type Cable Connector for use all types of with Armored & Jacketed Marine cables incorporating Wire Braid or Served (Single) Wire Armor in Ordinary, Wet & Hazardous Locations, providing a seal on the cable inner bedding and an environmental seal on the cable outer jacket. This product utilises a unique Compensating Displacement Seal (CDS) system which provides full compatibility with Restricted Breathing equipment. The cable gland provides mechanical cable retention and electrical continuity via armor wire termination. A reversible armour cone and AnyWay universal clamping ring arrangement allows the cable to be easily disconnected from the equipment, for maintenance and change out etc. This feature also facilitates remote make off procedures when the termination is to be conducted in confined spaces or in areas of restricted access. Separate tightening actions for the inner Compensating Displacement Seal (CDS) system and the armor termination affords maximum control over the pressure applied to the cable inner bedding. The T3CDS cable connector is available in NPT (standard) or Metric thread forms and the standard material is Brass grade CuZn39Pb3 (CW614N) to EN12168 with Electroless Nickel Plated Brass entry component. This product provides Nema 4X and IP68 ingress protection and is UL listed for use in Class I Zone I AEx e II applications and can be used in Class I Division 2 areas when installed in compliance with the NEC requirements.

TECHNICAL DATA	
Type	T3CDS
Design Specification	BS 6121:Part 1:1989, EN 50262:1999, UL 514B
ATEX Certification	SIRA06ATEX1283X
Code of Protection Category	ATEX (Ex) II 2/3 GD Ex d IIC, Ex e II, Ex nR II, Ex tD A21 IP66, Equipment Zone 1, Zone 2, Zone 21, & Zone 22 - Gas Groups IIA, IIB, IIC
Compliance Standards	EN 60079-0:2006, EN 60079-1:2004, EN 60079-7:2003, EN 60079-15:2005, EN 61241-0:2004, EN 61241-1:2004
IECEX Approval Number	IECEX SIR 07.005X
Code of Protection Category	Ex d IIC, Ex e II, Ex nR II, Ex tD A21 IP66
Compliance Standards	IEC 60079-0:2004, IEC 60079-1:2003, IEC 60079-7:2006, IEC 60079-15:2005, IEC 61241-0:2004, IEC 61241-1:2004
CSA Certification	1310517
Code of Protection Category	Class I, II, III, Class I Div 2 Groups ABCD, Class II Div 2 Groups EFG, Enclosure Type 3, 4 and 4X, Class III, Ex d IIC, Ex e II
Compliance Standards	CSA C22.2 No. 174-M1984, CSA C22.2 No. 25-1966, CAN/CSA-C22.2 No. 18-92, CAN/CSA-C22.2 No. 94-M91, CAN/CSA-E60079-0-2001, IEC 60079-0 1998, CAN/CSA-E79-7-95
UL Listing File Number	UBWE.E200163, CYMJ.E256366, FDJR.E256367
Code of Protection Category	Ordinary & Wet Locations, Class I, Zone 1, AEx e II, Class I, Zone 2, AEx e II
Compliance Standards	UL 514B, UL 60079-0, UL 60079-7
GOST R Certificate Number	POCC GB. Г Б05.Б01912
Code of Protection Category	Ex d IIC U / Ex e II U
Compliance Standards	ГОСТ P 52350.0-2005, ГОСТ P 52350.1-2005, ГОСТ P 52350.7-2005
GGTN Permit Number	PPC 00-18262
GOST K Certificate Number	KZ7500052.05.01.00063
RoK Permit for Use Number	08-067693
Lloyds Approval Number	01/00172
DNV Approval Number	E-6157
ABS Approval Number	01-LD 234401-PDA
Continuous Operating Temperature	-60°C to +130°C
Ingress Protection Rating	IP66, IP67, IP68
Deluge Protection Compliance	DTS01 : 91
Deluge Protection Document	ITS 01005029 - D
Standard Cable Connector Material	Brass with Electroless Nickel Plated Brass Entry Component
Seal Material	CMP SOLO LSF Thermoplastic Elastomer
Cable Type	Armored & Jacketed, Wire Braid Armor, Served (Single) Wire Armor (SWA).
Armor Clamping	Reversible Armor Cone & AnyWay Universal Clamping Ring
Sealing Technique	CMP Inner CDS System & Unique CMP "LRS"™ Outer Seal (Load Retention Seal)
Sealing Area(s)	Cable Inner Bedding & Cable Outer Jacket
Optional Accessories	Locknut, Shroud, Entry Thread Seal, Serrated Washer, Earth Tag, Adaptor/Reducer

Note: Versions with dedicated armour cones, Type T3CDSW – for SWA cables only, and Type T3CDSX for all other approved cable types also available.

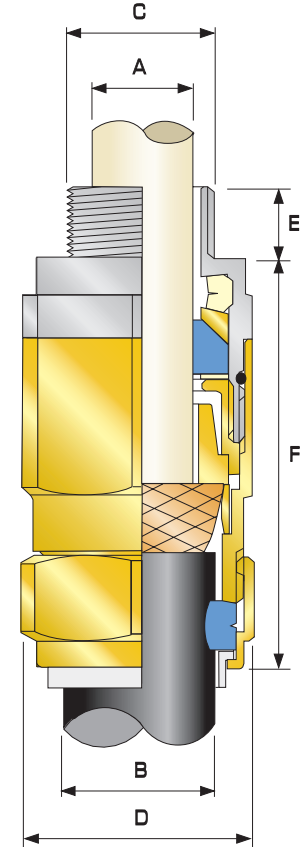

Note: Stepped Cone is suitable for SWA cables, Grooved Cone is suitable for all other approved armoured cables

Cable Connector Selection Table

Cable Connector Size	Available Entry Threads 'C'			Minimum Thread Length 'E'		Cable Bedding Diameter 'A'		Overall Cable Diameter 'B'		Armour Range †				Across Flats 'D'	Across Corners 'D'	Nominal Protrusion Length 'F'	Ordering Reference (NPT) #	Cable Gland Weight (Ozs)
	Standard	Option		NPT	Metric	Min	Max	Min	Max	Grooved Cone		Stepped Cone						
		NPT	Metric							Min	Max	Min	Max					
20S/16	1/2"	3/4"	M20	0.630	0.591	0.122	0.343	0.240	0.453	0.000	0.039	0.035	0.039	0.945	1.047	2.756	20S16T3CDS1RA731	6.25
20S	1/2"	3/4"	M20	0.630	0.591	0.240	0.461	0.374	0.626	0.000	0.039	0.035	0.049	0.945	1.047	2.756	20ST3CDS1RA731	6.25
20	1/2"	3/4"	M20	0.630	0.591	0.256	0.551	0.492	0.823	0.000	0.039	0.035	0.049	1.201	1.311	2.835	20T3CDS1RA731	9.25
25S	3/4"	1"	M25	0.669	0.591	0.437	0.787	0.551	0.866	0.000	0.039	0.049	0.063	1.476	1.594	3.228	25S3CDS1RA732	13.35
25	3/4"	1"	M25	0.669	0.591	0.437	0.787	0.717	1.031	0.000	0.039	0.049	0.063	1.476	1.594	3.228	25T3CDS1RA732	13.35
32	1"	1-1/4"	M32	0.787	0.591	0.669	1.035	0.933	1.335	0.000	0.039	0.063	0.079	1.811	2.008	3.346	32T3CDS1RA733	19.71
40	1-1/4"	1-1/2"	M40	0.787	0.591	0.866	1.268	1.098	1.591	0.000	0.039	0.063	0.079	2.165	2.402	3.386	40T3CDS1RA734	29.85
50S	1-1/2"	2"	M50	0.787	0.591	1.161	1.504	1.386	1.839	0.000	0.039	0.079	0.098	2.362	2.618	3.858	50S3CDS1RA735	37.14
50	2"	2-1/2"	M50	0.906	0.591	1.402	1.736	1.591	2.091	0.000	0.039	0.079	0.098	2.756	3.094	3.937	50T3CDS1RA736	53.54
63S	2"	2-1/2"	M63	0.906	0.591	1.579	1.969	1.795	2.339	0.000	0.039	0.079	0.098	2.953	3.276	4.252	63S3CDS1RA736	61.60
63	2-1/2"	3"	M63	0.984	0.591	1.858	2.205	2.150	2.594	0.000	0.039	0.079	0.098	3.150	3.504	4.355	63T3CDS1RA737	59.86
75S	2-1/2"	3"	M75	0.984	0.591	2.079	2.441	2.323	2.839	0.000	0.039	0.079	0.098	3.504	4.000	4.434	75S3CDS1RA737	82.54
75	3"	3-1/2"	M75	1.417	0.591	2.327	2.677	2.626	3.091	0.000	0.039	0.079	0.098	3.898	4.374	4.520	75T3CDS1RA738	112.64
90	3-1/2"	4"	M90	1.417	0.591	2.622	3.126	3.000	3.559	0.000	0.063	0.124	0.124	4.488	5.063	5.512	90T3CDS1RA739	179.50

All dimensions in inches

Note: †Alternative armor clamping range available for non-standard armour sizes. Marine approvals including Lloyds, DNV & ABS are also available from CMP Products. # Other thread forms are available.



PX2KX CABLE CONNECTOR

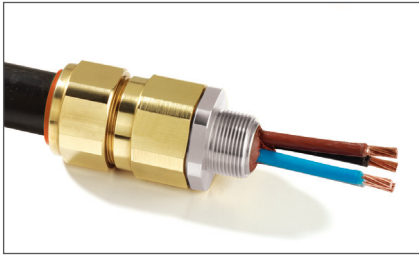

PX2KX Hazardous Location Cable Connector

CMP Type PX2KX Class I Division 1 ABCD Cable Connector for use with Armored & Jacketed cable providing a compound barrier seal around the cable conductors and an environmental seal on the cable outer jacket. In addition this UL listed cable connector also offers Class I Zone 1, AEx d IIC, Ex d IIC certification. The cable connector provides mechanical cable retention and electrical continuity via armour termination. A detachable armour cone and AnyWay universal clamping ring arrangement allows the cable to be easily disconnected from the equipment, for maintenance and change out etc. This feature also facilitates remote make off procedures when the termination is to be conducted in confined spaces or in areas of restricted access.

The PX2KX cable connector offers Nema 4X and IP68 ingress protection and is supplied in Brass grade CuZn39Pb3 (CW614N) to EN12168 with Electroless Nickel Plated Brass entry component as standard. The PX2KX is also IEC Ex Triple Certified Ex d, Ex e & Ex nR, offering a single solution that can be employed in accordance with both NEC and IEC codes of installation.

TECHNICAL DATA

Type	PX2KX
Design Specification	UL 514B, UL 886, UL 2225, EN 50262:1999, BS 6121:Part 1:1989
ATEX Certification	SIRA06ATEX1097X
Code of Protection Category	ATEX Ex d IIC II 2 GD Ex d IIC, Ex e II, Ex nR II, Ex tD A21 IP66, Equipment Zone 1, Zone 2, Zone 21, & Zone 22 - Gas Groups IIA, IIB, IIC
Compliance Standards	EN 60079-0: 2006, EN 60079-1: 2004, EN 60079-7: 2003, EN 60079-15: 2005, EN 61241-0: 2004 EN 61241-1: 2004
IECEX Approval Number	IECEX SIR 06.0044X
Code of Protection Category	Ex d IIC / Ex e II / Ex nR II / Ex tD A21 IP66 / Ex d I / Ex e I
Compliance Standards	IEC 60079-0:2004, IEC 60079-1:2003, IEC 60079-7:2001, IEC 60079-15:2005, IEC 61241-0:2004, IEC 61241-1:2004
UL Listing File Number	FLDW.E201187, FDJR.E256367
Code of Protection Category	Class I, Groups A, B, C & D, Class II, Groups E, F & G, Class I, Zone 1, AEx d IIC
Compliance Standards	UL514B, UL886, UL2225, UL2227
CUL Listing File Number	FLDW7.E201187
Code of Protection Category	Class I, Groups A, B, C & D, Class II, Groups E, F & G
Compliance Standards	UL514B, UL 886, UL 2225, UL2227
GOST R Certificate Number	POCC GB.ГБ 05.Б01912
Code of Protection Category	Ex d IIC U / Ex e II U
Compliance Standards	ГОСТ P 52350.0-2005, ГОСТ P 52350.1-2005, ГОСТ P 52350.7-2005
GGTN Permit Number	PPC 00-18262
GOST K Certificate Number	KZ7500052.05.01.00063
RoK Permit for Use Number	08-067693
Lloyds Approval Number	01/00172
DNV Approval Number	E-6157
ABS Approval Number	01-LD 234401-PDA
Continuous Operating Temperature	-60°C to +130°C
Ingress Protection Rating	IP66, IP67, IP68
Ingress Protection Document	5046 C549G
Deluge Protection Compliance	DTS01 : 91
Deluge Protection Document	5046 C549G-D
NEMA Rating	NEMA 4X
Standard Connector Material	Brass With Nickel Plated Entry Component
Alternative Connector Material	Stainless Steel, Aluminium
Seal Material	CMP SOLO LSF Thermoplastic Elastomer / Epoxy Resin Barrier Compound
Cable Type	Armored & Jacketed
Armor Clamping	Detachable Compound Tube / Armor Cone & AnyWay Universal Clamping Ring
Sealing Technique	Unique CMP "LRS"™ Outer Seal (Load Retention Seal)
Sealing Area(s)	Inner Compound Barrier & Cable Outer Jacket
Optional Accessories	Locknut, Shroud, Entry Thread Seal, Serrated Washer, Earth Tag, Adaptor/Reducer

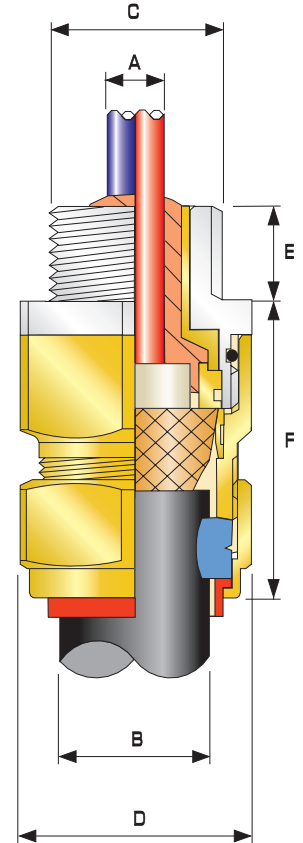

Cable Connector Selection Table

Cable Connector Size	Available Entry Threads 'C'			Minimum Thread Length 'E'		Diameter Over Conductors 'A'	Number of Cores	Overall Cable Diameter 'B'		Armour Range		Across Flats 'D'	Across Corners 'D'	Nominal Protrusion Length 'F'	Ordering Reference (NPT)	PVC Shroud Reference *	Cable Connector Weight (Ozs)
	Standard		Option	NPT	Metric			Min	Max	Min	Max						
	NPT	NPT	Metric	NPT	Metric	Max	Max	Min	Max	Min	Max	Max	Max				
20S/16	1/2"	3/4"	M20	0.630	0.591	0.496	15	0.240	0.453	0.0	0.039	0.945	1.047	2.303	20S16PX2KX1RA731	PVC04	7.06
20S	1/2"	3/4"	M20	0.630	0.591	0.496	15	0.374	0.626	0.0	0.039	0.945	1.047	2.303	20SPX2KX1RA731	PVC04	7.06
20	1/2"	3/4"	M20	0.630	0.591	0.496	15	0.492	0.823	0.0	0.039	1.201	1.311	2.382	20PX2KX1RA731	PVC06	8.11
25S	3/4"	1"	M25	0.669	0.591	0.689	29	0.551	0.866	0.0	0.039	1.476	1.594	2.657	25SPX2KX1RA732	PVC09	11.64
25	3/4"	1"	M25	0.669	0.591	0.689	29	0.717	1.031	0.0	0.039	1.476	1.594	2.657	25PX2KX1RA732	PVC09	11.64
32	1"	1-1/4"	M32	0.787	0.591	0.929	51	0.933	1.335	0.0	0.039	1.811	2.008	2.736	32PX2KX1RA733	PVC11	17.99
40	1-1/4"	1-1/2"	M40	0.787	0.591	1.181	80	1.098	1.591	0.0	0.039	2.165	2.402	3.071	40PX2KX1RA734	PVC15	25.40
50S	1-1/2"	2"	M50	0.787	0.591	1.441	122	1.386	1.839	0.0	0.039	2.362	2.618	2.972	50SPX2KX1RA735	PVC18	29.10
50	2"	2-1/2"	M50	0.906	0.591	1.614	149	1.591	2.091	0.0	0.039	2.756	3.094	3.169	50PX2KX1RA736	PVC21	30.34
63S	2"	2-1/2"	M63	0.906	0.591	1.886	205	1.795	2.339	0.0	0.039	2.953	3.276	3.602	63SPX2KX1RA736	PVC23	51.15
63	2-1/2"	3"	M63	0.984	0.591	2.114	259	2.150	2.594	0.0	0.039	3.150	3.504	3.622	63PX2KX1RA737	PVC25	56.44
75S	2-1/2"	3"	M75	0.984	0.591	2.354	320	2.323	2.839	0.0	0.039	3.504	4.000	3.898	75SPX2KX1RA7387	PVC28	81.13
75	3"	3-1/2"	M75	1.417	0.591	2.531	364	2.626	3.091	0.0	0.039	3.898	4.374	4.016	75PX2KX1RA738	PVC30	107.59
90	3-1/2"	4"	M90	1.417	0.591	2.965	500	3.000	3.559	0.0	0.063	4.488	5.063	4.724	90PX2KX1RA739	PVC32	176.37

All dimensions in inches

Note: *LSF Shrouds also available on request. Marine approvals including Lloyds, DNV & ABS are also available from CMP Products.

PXSS2K CABLE CONNECTOR

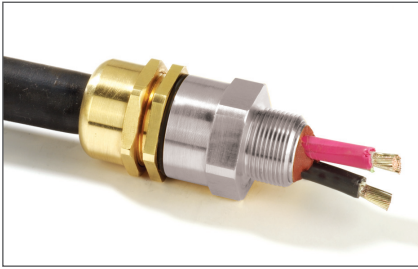

PXSS2K Hazardous Location Cable Connector

CMP Type PXSS2K Class I Division 2 ABCD Cable Connector for use with Non-Armored Marine & Tray Cable (Type TC) and Extra-Hard Usage Cord, providing a compound barrier seal around the cable conductors and an environmental seal on the cable outer jacket. In addition this UL listed cable connector also offers Class I Zone I, AEx d IIC, Ex d IIC certification. The cable connector provides mechanical cable retention. A combined detachable spacer and compound tube allows the cable to be easily disconnected from the equipment, for maintenance and change out etc. This feature also facilitates remote make off procedures when the termination is to be conducted in confined spaces or in areas of restricted access.

The PXSS2K cable connector offers Nema 4X and IP68 ingress protection and is supplied in Brass grade CuZn39Pb3 (CW614N) to EN12168 with Electroless Nickel Plated Brass entry component as standard. The PXSS2K is also IEC Ex Triple Certified Ex d, Ex e & Ex nR, offering a single solution that can be employed in accordance with both NEC and IEC codes of installation.

TECHNICAL DATA	
Type	PXSS2K
Design Specification	BS 6121:Part 1:1989, EN 50262:1999, UL 514B, UL 886, UL 2225, UL 2227
ATEX Certification	SIRA06ATEX1097X
Code of Protection Category	ATEX (Ex) II 2 GD Ex d IIC, Ex e II, Ex nR II, Ex tD A21 IP66, Equipment Zone 1, Zone 2, Zone 21, & Zone 22 - Gas Groups IIA, IIB, IIC
Compliance Standards	EN 60079-0:2006, EN 60079-1: 2004, EN 60079-7: 2003, EN 60079-15: 2005, IEC 61241-0: 2004 EN 61241-1: 2004
IECEx Approval Number	IECEx SIR 06.0044X
Code of Protection Category	Ex d IIC / Ex e II / Ex nR II / Ex tD A21 IP66 / Ex d I / Ex e I
Compliance Standards	IEC 60079-0:2004, IEC 60079-1:2003, IEC 60079-7:2001, IEC 60079-15:2005, IEC 61241-0:2004, IEC 61241-1:2004
UL Listing File Number	FLDW.E201187, CYMX.E161256, EBMB.E253914
Code of Protection Category	Class I, Div 2, ABCD, Class II, Div 2, F & G, Class I, Zone 1, AEx d IIC, AEx e II
Compliance Standards	UL514B, UL 886, UL 2225, UL2227
CUL Listing File Number	FLDW7.E201187, CYMX7.E161256
Code of Protection Category	Class I, Div 2, ABCD, Class II, Div 2, F & G
Compliance Standards	UL514B, UL 886, UL 2225, UL2227
GOST R Certificate Number	POCG GB. ГБ05.В01912
Code of Protection Category	Ex d IIC U / Ex e II U
Compliance Standards	ГОСТ P 52350.0-2005,ГОСТ P 52350.1-2005,ГОСТ P 52350.7-2005
GGTN Permit Number	PPC 00-18262
GOST K Certificate Number	KZ7500052.05.01.00063
RoK Permit for Use Number	08-067693
Lloyds approval Number	01/00172
DNV Approval Number	E-6157
ABS Approval Number	01-LD 234401-PDA
Continuous Operating Temperature	-60°C to +100°C
Ingress Protection Rating	IP66, IP67, IP68
Ingress Protection Document	5046 C549J
Deluge Protection Compliance	DTS01 : 91
Deluge Protection Document	5046 C549J-D
NEMA Rating	NEMA 4X
Standard Gland Connector Material	Brass With Nickel Plated Entry Component
Alternative Gland Connector Material	Stainless Steel, Nickel Plated Brass, Aluminium.
Seal Material	CMP SOLO LSF Thermoplastic Elastomer / Epoxy Resin Barrier Compound
Cable Type	Non-Armored Marine & Tray Cable (TC) and Extra-Hard Usage Cord
Sealing Technique	CMP Displacement Seal
Sealing Area(s)	Inner Compound Barrier & Cable Outer Jacket
Optional Accessories	Locknut, Shroud, Entry Thread Seal, Serrated Washer, Earth Tag, Adaptor/Reducer

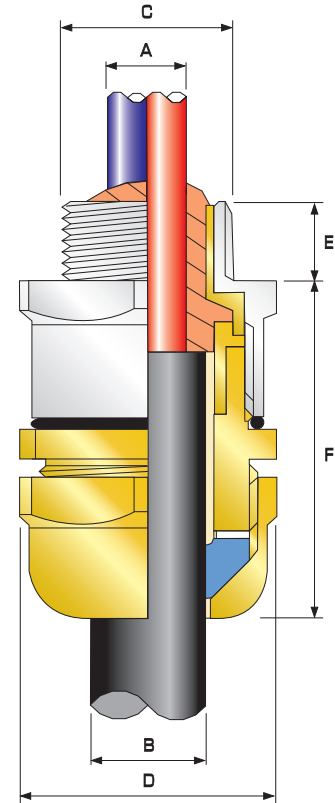

Cable Connector Selection Table

Cable Connector Size	Available Entry Threads 'C'			Minimum Thread Length 'E'		Diameter Over Conductors 'A'	Number of Cores	Overall Cable Diameter 'B'		Across Flats 'D'	Across Corners 'D'	Nominal Protrusion Length 'F'	Ordering Reference (NPT)	PVC Shroud Reference *	Cable Connector Weight (Ozs)
	Standard		Option	NPT	Metric			Min	Max						
	NPT	NPT	Metric	NPT	Metric			Max	Max						
20S/16	1/2"	3/4"	M20	0.630	0.591	0.496	15	0.122	0.343	0.945	1.047	2.303	20S16PXSS2K1RA731	PVC04	5.68
20S	1/2"	3/4"	M20	0.630	0.591	0.496	15	0.240	0.470	0.945	1.047	2.303	20SPXSS2K1RA731	PVC04	5.68
20	1/2"	3/4"	M20	0.630	0.591	0.496	15	0.260	0.530	1.201	1.311	2.382	20PXSS2K1RA731	PVC05	7.09
20L	1/2"	3/4"	M20	0.630	0.591	0.496	15	0.390	0.630	1.201	1.311	2.382	20LPXSS2K1RA731	PVC05	7.09
25	3/4"	1"	M25	0.669	0.591	0.689	29	0.440	0.780	1.476	1.594	2.657	25PXSS2K1RA732	PVC09	11.44
32	1"	1-1/4"	M32	0.787	0.591	0.929	51	0.670	1.030	1.811	2.008	2.736	32PXSS2K1RA733	PVC10	15.75
32L	1"	1-1/4"	M32	0.787	0.591	0.929	51	0.790	1.079	1.811	2.008	2.736	32LPXSS2K1RA733	PVC10	15.75
40	1-1/4"	1-1/2"	M40	0.787	0.591	1.181	80	0.870	1.260	2.165	2.402	3.071	40PXSS2K1RA734	PVC13	17.03
50S	1-1/2"	2"	M50	0.787	0.591	1.441	122	1.160	1.500	2.362	2.618	2.972	50SPXSS2K1RA735	PVC14	17.17
50	2"	2-1/2"	M50	0.906	0.591	1.614	149	1.400	1.730	2.756	3.094	3.169	50PXSS2K1RA736	PVC17	17.59
63S	2"	2-1/2"	M63	0.906	0.591	1.886	205	1.580	1.960	2.953	3.276	3.602	63SPXSS2K1RA736	PVC20	20.00
63	2-1/2"	3"	M63	0.984	0.591	2.114	259	1.860	2.200	3.150	3.504	3.622	63PXSS2K1RA737	PVC22	20.71
75S	2-1/2"	3"	M75	0.984	0.591	2.354	320	2.080	2.440	3.504	4.000	3.898	75SPXSS2K1RA737	PVC24	32.63
75	3"	3-1/2"	M75	1.417	0.591	2.5311	364	2.330	2.670	3.898	4.374	4.016	75PXSS2K1RA738	PVC26	36.89
90	3-1/2"	4"	M90	1.417	0.591	2.965	500	2.620	3.120	4.488	5.063	4.724	90PXSS2K1RA739	PVC31	76.61

All dimensions in inches

Note: *LSF Shrouds also available on request. Marine approvals including Lloyds, DNV & ABS are also available from CMP Products.



TMC CABLE CONNECTOR

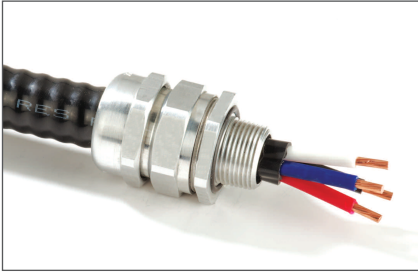

TMC Ordinary, Wet & Hazardous Location Cable Connector

CMP Type TMC Cable Connector suitable for use with Corrugated Interlocked & Continuously Welded Metal Clad (Type MC or MC-HL) or TECK armored and armored & jacketed cables in ordinary, wet & hazardous locations including Class II Division 1 & 2 installations. The cable connector provides mechanical retention and electrical continuity via the armor termination and an environmental seal on the cable outer jacket. In addition this UL listed cable connector also offers Class I Zone I, AEx e II certification. The re-usable compression spring feature providing both grounding and gripping functions to the cable armor, allows the cable to be easily disconnected from the equipment, for maintenance and change out etc.

The TMC cable connector offers Nema 4X and IP68 ingress protection and is supplied in Copper free Aluminum, Stainless Steel, or Electroless Nickel Plated Brass. The TMC is available in NPT (standard) and Metric thread forms, and is also IEC Ex Certified Ex e II, offering a single solution that can be employed in accordance with both NEC and IEC codes of installation.

TECHNICAL DATA	
Type	TMC
Design Specification	UL 514B, UL 886
CSA Approval Certificate Number	1129339
Code of Protection Category	Class II Div 1 & 2 Groups EFG, Class III Div 1 & 2, Class I Zone 1 Ex e II, Enclosure Type 3, 4 and 4X
Compliance Standards	CAN/CSA-C22.2 Number 18-92, CSA C22.2 Number 25-1966, CSA C22.2 Number 174-M1984, CAN/CSA-C22.2 Number 94-M91, CAN/CSA-E60079-0-2001, IEC 60079-0 1998, CAN/CSA-E79-7-95
UL Listing File Number	PJOX.E163112, CYMJ.E256366
Code of Protection Category	Class II Div 1 & 2 Groups EFG, Class III Div 1 & 2, Class I Zone 1 AEx e II, Ordinary & Wet Locations
Compliance Standards	UL 514B, UL 886, ANSI/UL 60079-0, ANSI/UL 60079-7
GOST R Certificate Number	POCC GB. ГБ 05.Б01912
Code of Protection Category	Ex e II
Compliance Standards	ГОСТ P 52350.0-2005, ГОСТ P 52350.7-2005
GGTN Permit Number	PPC 00-18262
GOST K Certificate Number	KZ7500052.05.01.00063
RoK Permit for Use Number	08-067693
Lloyds Approval Number	01/00172
DNV Approval Number	E-6157
ABS Approval Number	01-LD 234401-PDA
Continuous Operating Temperature	-60°C to +130°C
Ingress Protection Rating	IP66
NEMA Rating	NEMA 4X
Standard Cable Connector Material	Copper Free Aluminum (<0.4%)
Alternative Cable Connector Material	Electroless Nickel Plated Brass, Stainless Steel
Seal Material	CMP SOLO LSF Thermoplastic Elastomer
Cable Type	Corrugated & Interlocked Metal Clad Armor (MC) or TECK, Continuously Welded Metal Clad Armor (MCHL)
Armour Clamping	Earth Continuity in Contact With Metal Clad Armour
Sealing Technique	CMP Displacement Seal
Sealing Area(s)	Cable Outer Jacket
Optional Accessories	Locknut, Shroud, Entry Thread Seal, Serrated Washer, Earth Tag, Adaptor/Reducer

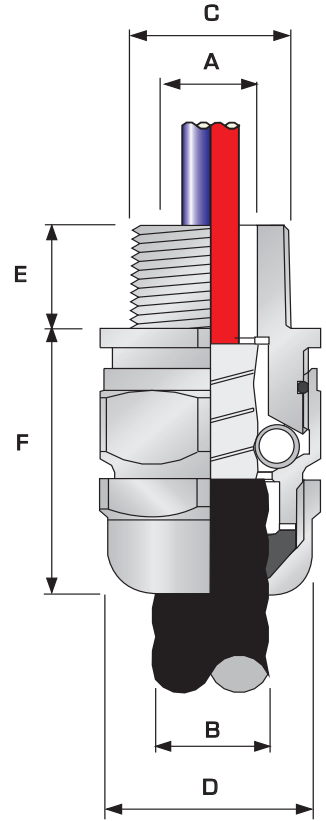

Cable Connector Selection Table

Order Reference			Entry Thread 'C'	Min Thread Length 'E'	Cable Armor Diameter 'A'				Cable Jacket Diameter 'B'		Nominal Assembly Length 'F'	Envelope Diameter 'D'		Shroud Reference*
Aluminum	NP Brass	S. Steel			NPT	End Stop In		End Stop Out		Min		Max	A/F	
TMC050SA	TMC050SNB	TMC050SSS	1/2"	0.59	-	-	0.342	0.503	0.354	0.550	2.20	1.18	1.31	PVC06
TMC050A	TMC050NB	TMC050SS	1/2"	0.59	-	-	0.437	0.669	0.510	0.787	2.20	1.42	1.57	PVC09
TMC050LA	-	-	1/2"	0.59	0.591	0.756	0.756	0.917	0.669	1.035	2.20	1.61	1.79	PVC10
TMC075LA	TMC075NB	TMC075SS	3/4"	0.59	-	-	-	-	-	-	-	-	-	-
TMC075LA	-	-	3/4"	0.63	0.775	0.969	0.969	1.150	0.910	1.268	2.24	1.96	2.18	PVC13
TMC100A	TMC100NB	TMC100SS	1"	0.63	-	-	-	-	-	-	-	-	-	-
TMC100LA	-	-	1"	0.63	1.083	1.228	1.228	1.386	1.161	1.504	2.24	2.16	2.40	PVC16
TMC125A	TMC125NB	TMC125SS	1-1/4"	0.63	-	-	-	-	-	-	-	-	-	-
TMC125LA	-	-	1-1/4"	0.63	1.320	1.461	1.461	1.618	1.402	1.736	2.37	2.36	2.62	PVC18
TMC150A	TMC150NB	TMC150SS	1-1/2"	0.63	-	-	-	-	-	-	-	-	-	-
TMC150LA	-	-	1-1/2"	0.63	1.508	1.677	1.677	1.854	1.579	2.008	2.58	2.78	3.06	PVC21
TMC200SA	TMC200SNB	TMC200SSS	2"	0.63	-	-	-	-	-	-	-	-	-	-
TMC150KLA	-	-	1-1/2"	0.63	1.772	1.933	1.933	2.087	1.858	2.205	2.49	2.96	3.28	PVC24
TMC200A	TMC200NB	TMC200SS	2"	0.63	-	-	-	-	-	-	-	-	-	-
TMC200LA	-	-	2"	0.90	-	-	-	-	-	-	-	-	-	-
TMC250SA	TMC250SNB	TMC250SSS	2-1/2"	0.90	2.052	2.161	2.161	2.320	2.079	2.441	2.50	3.14	3.49	PVC25
TMC200KLA	-	-	2"	0.90	-	-	-	-	-	-	-	-	-	-
TMC250A	TMC250NB	TMC250SS	2-1/2"	0.90	2.247	2.406	2.406	2.545	2.327	2.677	2.52	3.35	3.71	PVC27
TMC300A	TMC300NB	TMC300SS	3"	0.98	2.543	2.776	2.776	2.965	2.622	3.126	3.57	4.33	4.80	PVC32
TMC350A	TMC350NB	TMC350SS	3-1/2"	1.437	2.913	3.291	3.291	3.485	2.992	3.830	4.61	5.25	5.82	-
TMC400A	TMC400NB	TMC400SS	4"	1.437	-	-	3.500	4.020	3.700	4.220	7.66	5.28	5.84	-

All dimensions in inches

Note: *LSF Shrouds also available on request. Marine approvals including Lloyds, DNV & ABS are also available from CMP Products.

TMCX CABLE CONNECTOR

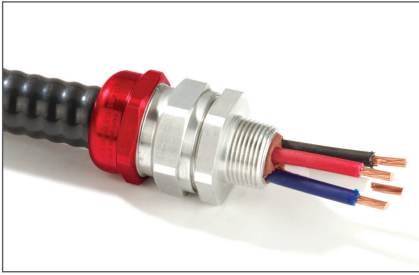

TMCX Hazardous Location Cable Connector

CMP Type TMCX Cable Connector suitable for use with Corrugated Interlocked & Continuously Welded Metal Clad (Type MC or MC-HL) or TECK armored and armored & jacketed cables in ordinary, wet & hazardous locations including Class I Division 1 & 2 installations. The cable connector provides mechanical retention and electrical continuity via the armor termination and an environmental seal on the cable outer jacket. In addition this UL listed cable connector also offers Class I Zone I, AEx d IIC certification. The re-usable compression spring feature providing both grounding and gripping functions to the cable armor, allows the cable to be easily disconnected from the equipment, for maintenance and change out etc.

The TMCX cable connector offers Nema 4X and IP68 ingress protection and is supplied in Copper Free Aluminum, Stainless Steel, or Electroless Nickel Plated Brass. The TMCX is available in NPT (standard) and Metric thread forms, and is also IEC Ex Certified Ex d IIC & Ex e II, offering a single solution that can be employed in accordance with both NEC and IEC codes of installation.

TECHNICAL DATA	
Type	TMCX
Design Specification	UL 514B, UL 886, UL 2225, UL 2279
CSA Approval Certificate Number	1129339
Code of Protection Category	Class I Div 1 & 2 Groups ABCD, Class II Div 1 & 2 Groups EFG, Class III Div 1 & 2, Class I Zone 1 Ex d IIC, Enclosure Type 3, 4 and 4X
Compliance Standards	CAN/CSA-C22.2 Number 18-92, CSA C22.2 Number 25-1966, CSA C22.2 Number 174-M1984, CAN/CSA-C22.2 Number 94-M91, CAN/CSA-E60079-0-2001, IEC 60079-0 1998, CAN/CSA E79-1-95, CAN/CSA-E79-7-95
UL Listing File Number	CYMX7.E161256, CYMJ.E256366
Code of Protection Category	Class I Div 1 & 2 Groups ABCD, Class II Div 1 & 2 Groups EFG, Class III Div 1 & 2, Class I Zone 1 AEx d IIC, Ordinary & Wet Locations
Compliance Standards	UL 514B, UL 886, UL 2225, UL 2227, ANSI/UL 60079-0, ANSI/UL 60079-1
GOST R Certificate Number	POCC GB. ГБ05.В01912
Code of Protection Category	Ex d IIC U / Ex e II U
Compliance Standards	ГОСТ Р 52350.0-2005, ГОСТ Р 52350.1-2005, ГОСТ Р 52350.7-2005
GGTN Permit Number	PPC 00-18262
GOST K Certificate Number	KZ7500052.05.01.00063
RoK Permit for Use Number	08-067693
Lloyds Approval Number	01/00172
DNV Approval Number	E-6157
ABS Approval Number	01-LD 234401-PDA
Continuous Operating Temperature	-60°C to +130°C
Ingress Protection Rating	IP66
NEMA Rating	NEMA 4X
Standard Cable Connector Material	Copper Free Aluminum (<0.4%)
Alternative Cable Connector Material	Electroless Nickel Plated Brass, Stainless Steel
Seal Material	CMP SOLO LSF Thermoplastic Elastomer / Epoxy Resin Barrier Compound
Cable Type	Corrugated & Interlocked Metal Clad Armor (MC) or TECK, Continuously Welded Metal Clad Armor (MCHL)
Armor Clamping	Earth Continuity in Contact With Metal Clad Armour
Sealing Technique	CMP Displacement Seal
Sealing Area(s)	Inner Compound Barrier & Cable Outer Jacket
Optional Accessories	Locknut, Shroud, Entry Thread Seal, Serrated Washer, Earth Tag, Adaptor/Reducer

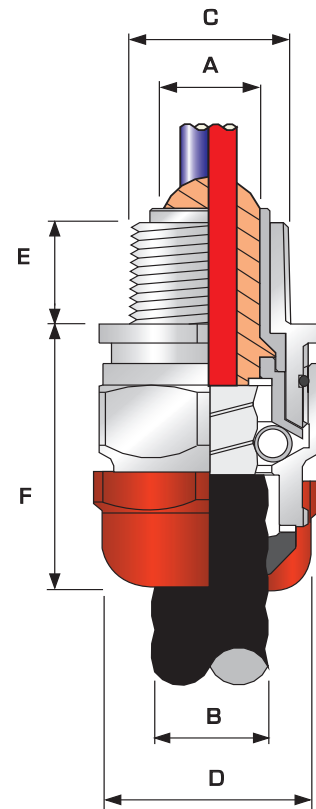

Cable Connector Selection Table

Order Reference			Entry Thread 'C'		Min Thread Length 'E'	Cable Armor Diameter 'A'				Cable Jacket Diameter 'B'		Nominal Assembly Length 'F'	Envelope Dia. 'D'		Compound Weight in ounces	Shroud Reference*
Aluminum	NP Brass	S. Steel	NPT	Metric		End Stop In		End Stop Out		Min	Max		A/F	A/C		
						Min	Max	Min	Max	Min	Max					
TMCX050SA	TMCX050SNB	TMCX050SSS	1/2"	M20	0.59	-	-	0.342	0.503	0.354	0.550	2.20	1.18	1.31	1/2	PVC06
TMCX050A	TMCX050NB	TMCX050SS	1/2"	M20	0.59	-	-	0.437	0.669	0.550	0.787	2.20	1.42	1.57	1/2	PVC09
TMCX075A	TMCX075NB	TMCX075SS	3/4"	M25	0.59	0.591	0.756	0.756	0.917	0.669	1.035	2.20	1.61	1.79	1/2	PVC10
TMCX100A	TMCX100NB	TMCX100SS	1"	M32	0.63	0.775	0.969	0.969	1.150	0.910	1.268	2.24	1.96	2.18	1-1/4	PVC13
TMCX125A	TMCX125NB	TMCX125SS	1-1/4"	M40	0.63	1.083	1.228	1.228	1.386	1.161	1.504	2.24	2.16	2.40	1-1/4	PVC16
TMCX150A	TMCX150NB	TMCX150SS	1-1/2"	M50	0.63	1.320	1.461	1.461	1.618	1.402	1.736	2.37	2.36	2.62	2	PVC18
TMCX200SA	TMCX200SNB	TMCX200SSS	2"	M50	0.63	1.508	1.677	1.677	1.854	1.579	2.008	2.60	2.78	3.06	3	PVC21
TMCX200A	TMCX200NB	TMCX200SS	2"	M63	0.63	1.772	1.933	1.933	2.087	1.858	2.205	2.81	2.96	3.28	4-3/4	PVC24
TMCX250SA	TMCX250SNB	TMCX250SSS	2-1/2"	M63	0.90	2.052	2.161	2.161	2.320	2.079	2.441	2.88	3.14	3.49	9-1/2	PVC25
TMCX250A	TMCX250NB	TMCX250SS	2-1/2"	M75	0.90	2.247	2.406	2.406	2.545	2.327	2.677	2.88	3.35	3.71	9-1/2	PVC27
TMCX300A	TMCX300NB	TMCX300SS	3"	M90	0.98	2.543	2.776	2.776	2.965	2.622	3.126	3.92	4.33	4.80	12-1/2	PVC32
TMCX350A	TMCX350NB	TMCX350SS	3-1/2"	M100	1.437	2.913	3.291	3.291	3.485	2.992	3.830	4.61	5.25	5.82	19	-
TMCX400A	TMCX400NB	TMCX400SS	4"	M110	1.437	-	-	3.500	4.020	3.700	4.220	7.66	5.25	5.84	19	-

All dimensions in inches

Note: *LSF Shrouds also available on request. Marine approvals including Lloyds, DNV & ABS are also available from CMP Products.



THREAD CONVERSION ADAPTORS AND REDUCERS

THREAD CONVERSION ADAPTORS AND REDUCERS

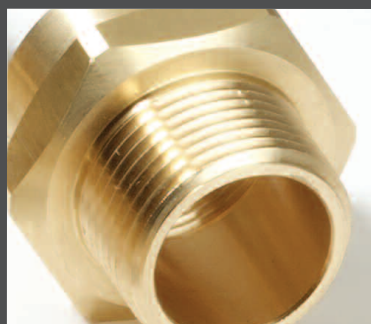



■ APPLICATION

The CMP range of Thread Conversion Adaptors, Reducers and associated products are available for use in Industrial, Marine and Hazardous Area applications, and are particularly suited to construction projects where a high volume of cables of all types and sizes are being installed. When the cable gland fits the cable but its connecting thread differs from that of the equipment the best solution may be to use a CMP thread conversion adaptor, especially when schedules are critical and time is of the essence. CMP thread conversion adaptors and reducers offer the flexibility of allowing the job to progress by using a standard off the shelf product to save time and ultimate cost compared with modifying hole sizes in equipment.

■ PRODUCTS

In addition to Thread Conversion Adaptors and Reducers, CMP Products also provides, Unions, Stopper Plugs, Breather / Drain Plugs and Insulated Adaptors. All products in this range are available in a variety of materials, both metallic and non-metallic, and can be supplied in a combination of different thread forms and sizes including Metric, PG, NPT, BSP etc.

■ SPECIFICATIONS & APPROVALS

CMP Industrial, Marine and Hazardous Area Thread Conversion Adaptors, Reducers, Stopper Plugs and Breather Drain Plugs comply with the latest IEC standards and are offered with certification from a host of internationally recognised bodies. This range of certification includes ATEX, IEC Ex, CSA, UL, GOST R, GOST K and more.



ORDERING DEFINITIONS (HOW TO ORDER)

When selecting and installing certified electrical equipment and components in potentially explosive atmospheres, it is the users responsibility to ensure that the local industry codes of practice are observed and followed, for example EN 60079-14, IEC 60079-14, or NFPA 70 / NEC 500.

KEY TO ORDERING REFERENCES FOR ADAPTORS, REDUCERS & STOPPER PLUGS

HOW TO ORDER - To determine ordering reference please select from the tables below in the following fashion :-
Form of protection - Option (if required) - Thread Form - Thread Size - Material

E - X - A - M - P - L - E					
Product Type	Form of Protection	Options	Thread Form	Thread Size	Material
▼	▼	▼	▼	▼	▼
▼	▼	▼	▼	▼	▼
▼	▼	▼	▼	▼	▼
From Index Opposite	From Table A below	From Table B below	From Table C below	From Table D below	From Table E below
▼	▼	▼	▼	▼	▼
▼	▼	▼	▼	▼	▼
▼	▼	▼	▼	▼	▼
▼	▼	▼	▼	▼	▼
757	E	R	M	2	5

Stopper Plug Options						
Description	Allen key recess	Metallic			Non-Metallic	
		Ex 'd'	Ex 'e'	Industrial	Ex 'e'	Industrial
747 Recessed Non-Tamper Proof Type 'A'	✓	✓	✓	✓	✓	✓
747 Recessed Tamper Proof Type 'B'	✓	✓	✓	✓	✓	✓
757 Hexagon Head	x	✓	✓	✓	✓	✓
757 Hexagon Head c/w 'O' ring seal (*)	x	✓	✓	✓	✓	✓
767 Dome Head	✓	✓	✓	✓	✓	✓
767 Dome Head c/w 'O' ring seal (*)	✓	✓	✓	✓	✓	✓

Note * This option is available only with parallel thread Stopper Plugs

Table A

Code	Form of Protection
D	Dual Certified Ex 'd' / Ex 'e'
E	Increased Safety Ex 'e'
F	Flameproof Ex 'd'
G	General Purpose Industrial
M	Group 1 Mining (Ex 'd')
U	UL Listed - Hazardous Locations
C	CSA Approved - Ex d / Ex e

Table B

Code	Options
A	Externally Secured - Non Tamper Proof Ex 'd' Stopper Plug (Type A)
B	Internally Secured - Tamper Proof Ex 'd' Stopper Plug (Type B)
R	Optional 'O' ring

Table C

Code	Thread Form
M	Metric
N	NPSM
T	NPT
P	PG
B	BSPP
I	E.T. (Imperial)
S	BSPT

Table D

Code	Thread Size						
	Metric 'M'	NPSM 'N'	NPT 'T'	PG 'P'	BSP 'B'	Imperial 'I'	BSP 'S'
1A	-	-	-	7	-	-	-
1	16	1/2"	1/2"	9	1/2"	5/8"	1/2"
2	20	3/4"	3/4"	11	3/4"	3/4"	3/4"
3	25	1"	1"	13.5	1"	1"	1"
4	32	1-1/4"	1-1/4"	16	1-1/4"	1-1/4"	1-1/4"
5	40	1-1/2"	1-1/2"	21	1-1/2"	1-1/2"	1-1/2"
6	50	2"	2"	29	2"	2"	2"
7	63	2-1/2"	2-1/2"	36	2-1/2"	2-1/2"	2-1/2"
8	75	3"	3"	42	3"	3"	3"
9	90	3 1/2"	3 1/2"	48	3 1/2"	3-1/2"	3 1/2"
10	100	4"	4"	-	4"	4"	4"

Table E

Code	Material
-	Brass
1	Aluminium
2	Nylon
3	Mild Steel
4	Stainless Steel
5	Nickel Plated Brass

Other variations available on request

Notes: Nominal dimensions shown in this catalogue may vary due to material availability. All dimensions shown are in millimetres unless otherwise stated. Within the parameters of its hazardous area certification CMP products reserves the right to change the design and / or dimensions of any of the products illustrated without notice. For further information please contact CMP Products.

CMP Products Terms & Conditions will apply to all sales orders unless otherwise contractually agreed. These can be obtained from CMP offices or online at www.cmp-products.com

781 SERIES

Breather/Drain Plugs

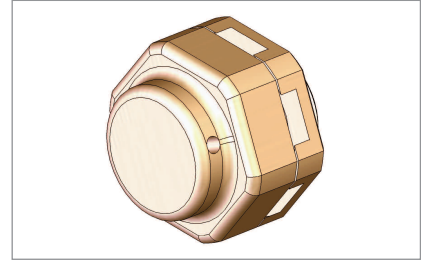
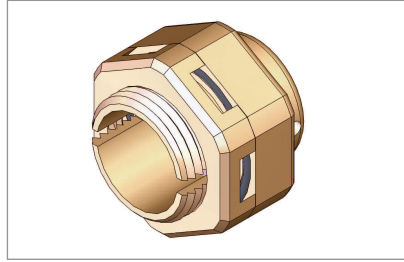

Breather / Drain Plug Type 781 with increased Safety Ex e II form of protection.

The CMP Type 781 Breather / Drain Plug is designed for Increased Safety Ex e apparatus that is susceptible to condensation or prone to moisture collection or ingress during normal operation. The Type 781 is designed to act as both a drainage device, when mounted in a bottom entry of the equipment, and also to enable the inside air to breathe with the external environment under normal ambient and atmospheric conditions, whilst excluding further dust and moisture from penetrating the enclosure. The Type 781 Breather / Drain Plug is supplied complete with an integral entry thread 'O' ring seal, and a castellated locknut to facilitate drainage from inside the enclosure. A General Purpose Industrial version is also available.

Metallic Breather / Drain Plugs are available in Brass, Aluminium or Stainless Steel and can be supplied for both Industrial and Hazardous Area applications, with Ex e Component Approval.

Other thread forms (equivalent to metric sizes M20 and M25 only), including PG, BSPP, NPSM and Imperial (ET) available on request. Please refer to Table D on page 161 for further information on these options.

Technical Data	
Type	781
Design Specification	BS 6121: Part 1: 1989.
ATEX Certification Detail	SIRA 01 ATEX 1284U
Code of Protection Category	ATEX II 2 GD Ex e II Component, Zone 1, Zone 2, Zone 21, & Zone 22 - Gas Groups IIA, IIB, IIC
IECEX Certification Detail	IECEX SIR07.0054U
Code of Protection Category	Ex e II / Ex tD A21 IP6X
Compliance Standards	EN 60079-0, EN 60079-7, EN 61241-1, IEC 60079-0, IEC 60079-7, IEC 61241-1
Continuous Operating Temperature	-60°C to +200°C
Ingress Protection Rating	IP66 (When fitted in a bottom entry, perpendicular manner)
Materials	Brass, Nickel Plated Brass, Aluminium, Stainless Steel, Nylon
Accessories Included	Integral Entry Thread 'O' Ring Seal, Castellated Locknut

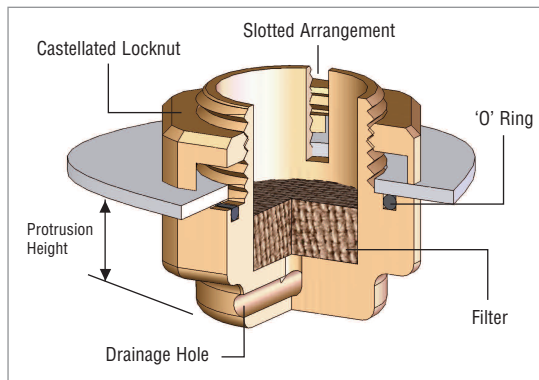

- Filter prevents any dirt or other foreign bodies from entering the enclosure
- Breathing capabilities help to combat the build up of moisture and potential condensation in the apparatus.
- Slotted Entry Threads and Castellated Locknut allows excess water to flow into inverted drain device.
- Draining features enable release of any water that has penetrated the apparatus whilst maintaining the Increased Safety form of protection.
- Integral 'O' Ring ensures an effective seal at the interface between the Breather/Drain device and the equipment.

Product Selection Table *						
Ordering Reference	Thread Size	Minimum Thread Length	Protrusion Height	Across Flats Dimension	Across Corners Dimensions	Installation Torque (Nm)
781EM2	M20 X 1.5	15	18.0	30.0	33.0	7
781EM3	M25 X 1.5	15	17.0	31.5	35.0	10
781ET1	1/2" NPT	15	18.0	30.0	33.0	7
781ET2	3/4" NPT	15	17.0	31.5	35.0	10

All dimensions shown are in millimetres unless otherwise stated

Marked with ATEX certification details as standard. Alternative certification marking shown in the table below can be applied if requested at the time of ordering.

Additional Approvals	
GOST Ex Approval Certificate	POCC GB.ГБ 05.B01367, POCC GB.ГБ 05.B01369
CSA Approval Certificate	1055233 Ex e II, IP66

Note * Please refer to ordering guide tables on page 161 for reference definitions, denoting material variants

737 SERIES Adaptors & Reducers

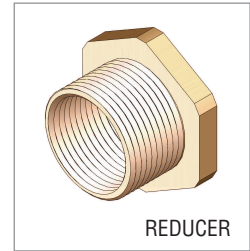
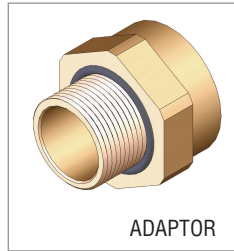

Thread Conversion Adaptor & Reducer Type 737 with Flameproof Ex d IIC & Increased Safety Ex e II forms of protection.

The CMP Type 737 range of Thread Conversion Adaptors & Reducers is designed to provide flexibility and versatility in the execution of construction works when there is a conflict between the type or size of the cable gland thread and the cable entry hole in the equipment. These Thread Conversion Adaptors & Reducers are available with Male to Female connection threads and can be supplied with thread conversion between the forward and rear threads to either an increased or reduced size or a different thread type, e.g. Metric to NPT, or NPT to Metric. Please refer to page 161 for further information on the options available. A General Purpose Industrial version is also available.

CMP 737 Thread Conversion Adaptors & Reducers are available in Brass, Aluminium, Stainless Steel or Nylon and can be supplied for both Industrial and Hazardous Area applications, with Ex 'd' & Ex 'e' Component Approval (Nylon Version is Ex e only).

The CMP 737 Adaptor & Reducer range is also optionally available with an integral 'O' Ring seal when the male thread is parallel. A non-metallic version is also available on request to complement non metallic enclosures.

Technical Data	
Type	737
Design Specification	BS 6121: Part 1: 189, EN 50262:1999
ATEX Certification Detail	SIRA O1 ATEX 1284U, SIRA O1 ATEX 1003
Code of Protection Category	ATEX Ex d IIC & Ex e II, Component and Equipment, Zone 1, Zone 2, Zone 21, & Zone 22 - Gas Groups IIA, IIB, IIC ATEX Ex e I & Ex e I. ATEX Ex e II only on Nylon version.
IECEX Certification Detail	IECEX SIR07.0052U
Code of Protection Category	Ex d I / Ex e I / Ex d IIC / Ex e II / Ex tD A21 IP6X (Ex e II / Ex tD A21 IP6X for Nylon only)
Compliance Standards	EN 60079-0, EN 60079-1, EN 60079-7, EN 61241-1, IEC 60079-0, IEC 60079-1, IEC60079-7, IEC 61241-1
Continuous Operating Temperature	-60°C to +200°C (Metallic), -20°C to +60°C (Nylon)
Ingress Protection Rating	IP66 or IP68 when fitted with a CMP 'O' Ring or Entry Thread Sealing Washer
Materials	Brass, Nickel Plated Brass, Aluminium, Stainless Steel
Optional Accessories	Locknut, Serrated Washer, Earth Tag, Entry Thread Sealing Washer

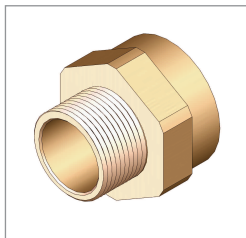

CMP 737 Adaptor

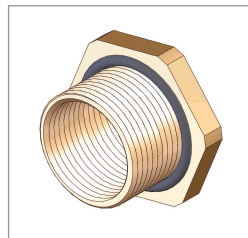

CMP 737 Reducer with optional 'O' ring

Key to Ordering References for 737 Adaptors & Reducers

Product Type	Form of Protection	Options	Male Thread Form	Male Thread Size	Female Thread Form	Female Thread Size	Material
From Index on Page 1	From Table A on Page 2	From Table B on Page 2	From Table C on Page 2	From Table D on Page 2	From Table C on Page 2	From Table D on Page 2	From Table E on Page 2
737	D	R	M	3	M	2	4

HOW TO ORDER *

e.g. 737 – D – M – 2 – M – 3 – 4
= Dual Certified Ex d & Ex e – M20 (M) x M25 (F) - Stainless Steel.

Standard Hazardous Area Marking Includes for ATEX certification. When ordering please notify CMP Products in your order if alternative approval markings are required.

Note: When ordering Adaptors & Reducers always state the Male Thread size first.

Note: The 'O' ring detail illustrated is an optional extra.

It should be noted that when using CMP Type 737 Thread Conversion Adaptors and Reducers in association with Explosion Protected electrical equipment the following basic rules must be observed in line with good engineering practice:-

1. No more than one conversion adaptor or reducer should be used at one time on any given cable entry.
2. Stopping plugs should be fitted directly into unused entries of the equipment, and not into an adaptor or reducer.
3. The female connection thread of a Thread Conversion Adaptor shall 'step' not more than one 'size' up in the case of a thread gender change.

Example ; M20 (M) to M25 (F) or M20 (M) to 3/4" NPT (f) is permitted
Where as M20 (M) to M32 (F) or M20 (M) to 1" NPT (F) is not permitted

Additional Approvals	
IEC Approval Certificate	SIRA 05 Y 1089U
GOST Ex Approval Certificate	POCC GB. ГЕ05.Б01367, POCC GB. ГЕ05.Б01369
CSA Approval Certificate	1055233 Class I ABCD, Class II EFG, IP68 TYPE 4X Ex d / Ex e IIC
UL Listing File Reference	EBNV.E214221 Class I ABCD, Class II EFG and Class III

Note * : Please refer to the thread conversion options on page 164 opposite and the ordering guide tables on page 161 for reference definitions. Other Thread Variations available on request. Please refer to page 165 for dimensions of type 737 adaptor and reducer products.



737 SERIES

Adaptors & Reducers

Dimension Data Tables

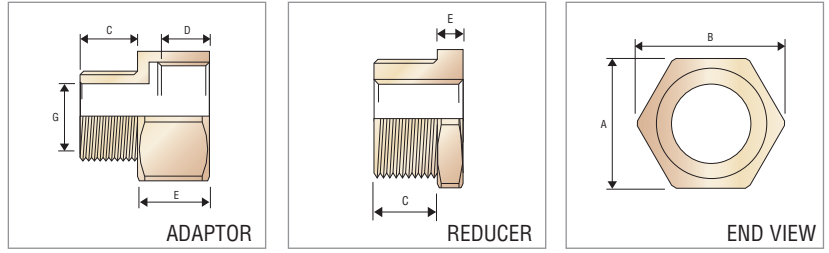

Table A

MALE THREAD SIZE	FEMALE THREAD SIZE																															
	METRIC										NPT & BSPP										PG											
	M16	M20	M25	M32	M40	M50	M63	M75	M90	M100	1/2"	3/4"	1"	1-1/4"	1-1/2"	2"	2-1/2"	3"	3-1/2"	4"	PG7	PG9	PG11	PG13.5	PG16	PG21	PG29	PG36	PG42	PG48		
METRIC																																
M16	A01	A01								A14											A01	A01	A01	A01	A01							
M20	R01	A02	A03							A02	A03										R01	R01	A02	A02	A04	A03						
M25	R03	R03	A04	A06						R03	A04	A16									R03	R03	R03	R03	A04	A04						
M32	R05	R05	R05	A06	A08					R05	R05	A17	A08								R05	R05	R07	R05	R05	A07	A35					
M40	R06	R06	R06	R06	A08	A09				R06	R07	R06	A18	A09							R06	R06	R06	R06	R06	R06	A08	A09				
M50	R07	R07	R07	R07	R07	A10	A11			R07	R08	R07	R07	A20	A21						R07	R07	R07	R07	R07	R07	R07	A10	A10	A11		
M63	R08	R08	R08	R08	R08	R08	A11	A31		R08	R08	R08	R08	R08	A24	A22					R08	R08	R08	R08	R08	R08	R08	R08	R08	A24		
M75	R09	R09	R09	R09	R09	R09	R09	A31	A12	R09	R09	R09	R09	R09	R09	A22	A23				R09	R09	R09	R09	R09	R09	R09	R09	R09	R09	R09	
M90	R10	R10	R10	R10	R10	R10	R10	R092	A12	A13	R10	R10	R10	R10	R10	R10	R10	A24	A25	A26	R10	R10	R10	R10	R10	R2	R10	R10	R10	R10	R10	
M100	R11	R11	R11	R11	R11	R11	R11	R11	A13	A13	R11	R11	R11	R11	R11	R11	R11	R11	A25	A26	R11	R11	R11	R11	R11	R11	R11	R11	R11	R11	R11	
NPT & BSPP																																
1/2"	R01	A27	A03							A02	A03										R01	R01	A27	A27	A27	A04						
3/4"	R03	R03	A04	A16						R03	A04	A16									R03	R03	R03	R03	A04	A04						
1"	R12	R05	R05	A07	A35					R05	R05	A07	A35								R05	R05	R05	R05	R05	A07	A35					
1-1/4"	R13	R12	R12	R12	A18	A28				R12	R12	R12	A35	A09							R12	R12	R12	R12	R12	R12	A18	A28				
1-1/2"	R13	R13	R13	R13	R13	A28	A31			R13	R13	R13	R139	A09	A36						R13	R13	R13	R13	R13	R13	R13	A28	A29	A31		
2"	R14	R14	R14	R14	R14	R14	A11	A31		R14	R14	R14	R14	R14	A36	A31					R14	R14	R14	R14	R14	R14	R14	R14	R14	A31		
2-1/2"	R15	R15	R15	R15	R15	R15	A32	A33		R15	R15	R15	R15	R15	R15	A32	A37				R15	R15	R15	R15	R15	R15	R15	R15	R15	R15	R15	
3"	R16	R16	R16	R16	R16	R16	R16	A33	A34	R16	R16	R16	R16	R16	R16	R16	A25	A38	A39	R16	R16	R16	R16	R16	R16	R16	R16	R16	R16	R16		
3-1/2"	R17	R17	R17	R17	R17	R17	R17	R17	A34	A34	R17	R17	R17	R17	R17	R17	R17	R17	R17	A38	A39	R17	R17	R17	R17	R17	R17	R17	R17	R17	R17	R17
4"	R18	R18	R18	R18	R18	R18	R18	R18	R18	R18	R18	R18	R18	R18	R18	R18	R18	R18	R18	R18	A39	R18	R18	R18	R18	R18	R18	R18	R18	R18	R18	R18
PG																																
PG7	A01	A01								A14											A02	A02	A01	A01								
PG9	A01	A01								A14											A02	A02	A01	A01								
PG11	A02	A02	A03							A02	A03										A02	A02	A02	A02	A02							
PG13.5	A02	A02	A03							A02	A03										R01	R01	A02	A02	A03	A03						
PG16	R03	A27	A04	A06						A03	A03	A16									R02	R02	R02	R02	A03	A40						
PG21	R04	R04	A05	A06	A08					R04	A15	A16									R04	R04	R04	R04	R04	A05	A10					
PG29	R06	R06	R06	R06	A08	A09				R06	R06	A18	A18	A19							R06	R06	R06	R06	R06	R06	A08	A09				
PG36	R07	R07	R07	R07	R07	A28	A11			R07	R07	R07	A19	A19							R07	R07	R07	R07	R07	R07	A09	A10	A11			
PG42	R07	R07	R07	R08	R08	A10	A24			R07	R07	R07	R07	R07	A21						R07	R07	R07	R07	R07	R07	R07	A10	A11			
PG48	R08	R14	R14	R08	R14	R14	A11	A31		R08	R08	R08	R08	R08	A21	A22					R08	R08	R08	R08	R08	R08	R08	R08	R08	R08	R08	

Table B

737 ADAPTOR DETAIL	A01	A02	A03	A04	A05	A06	A07	A08	A09	A10	A11	A12	A13	A14	A15	A16	A17	A18	A19	A20
Across Flats Dimension 'A'	24.0	24.0	30.0	30.0	33.0	36.0	36.0	46.0	55.0	60.0	70.0	100.0	110.0	24.0	46.0	41.0	41.0	46.0	55.0	55.0
Across Corners Diameter 'B'	26.6	26.6	33.3	33.3	36.6	40.0	40.0	51.0	61.0	66.5	77.6	110.0	122.0	26.6	51.0	43.5	46.0	51.0	61.0	61.0
Male Thread Length 'C'	15.0	15.0	15.0	15.0	15.0	15.0	15.0	15.0	15.0	15.0	15.0	15.0	15.0	19.0	15.0	15.0	15.0	15.0	15.0	15.0
Female Thread Length 'D'	16.0	16.0	16.0	16.0	16.0	16.0	16.0	16.0	16.0	21.0	16.0	20.0	20.0	16.0	16.0	16.0	16.0	16.0	15.0	16.0
Protrusion Length 'F'	20.0	20.0	20.0	20.0	20.0	20.0	20.0	20.0	20.0	6.0	20.0	24.0	20.0	20.0	20.0	20.0	20.0	20.0	27.0	20.0
Nominal Bore 'G'	8.0	13.5	13.5	19.0	20.0	20.0	26.0	29.0	32.0	42.0	42.0	65.0	79.3	9.7	20.0	20.0	26.0	32.0	29.0	42.0
737 ADAPTOR DETAIL	A21	A22	A23	A24	A25	A26	A27	A28	A29	A30	A31	A32	A33	A34	A35	A36	A37	A38	A39	A40
Across Flats Dimension 'A'	65.0	80.0	95.0	70.0	95.0	123.0	27.0	55.0	60.0	70.0	80.0	80.0	100.0	114.0	46.0	65.0	95.0	110.0	127.0	36.0
Across Corners Diameter 'B'	72.0	89.0	105.0	80.0	105.0	138.0	30.0	6.0	66.5	77.6	89.0	89.0	110.0	132.0	51.0	72.0	105.0	122.0	146.0	40.0
Male Thread Length 'C'	15.0	15.0	15.0	15.0	15.0	25.0	15.0	16.0	25.0	16.0	16.0	23.0	5.0	36.0	16.0	16.0	23.0	25.0	36.0	15.0
Female Thread Length 'D'	16.0	23.0	25.0	16.0	25.0	25.0	16.0	16.0	17.0	16.0	16.0	16.0	20.0	22.0	16.0	16.0	25.0	27.0	36.0	16.0
Protrusion Length 'F'	20.0	27.0	30.0	20.0	30.0	35.0	20.0	20.0	20.0	20.0	20.0	20.0	24.0	38.0	20.0	20.0	30.0	32.0	39.0	20.0
Nominal Bore 'G'	42.0	55.0	65.0	55.0	75.0	80.0	14.0	38.0	38.0	38.0	49.0	60.0	75.0	75.0	26.3	38.0	60.0	75.0	75.0	14.0
737 REDUCER DETAIL	R01	R02	R03	R04	R05	R06	R07	R08	R09	R10	R11	R12	R13	R14	R15	R16	R17	R18	-	-
Across Flats Dimension 'A'	24.0	27.0	30.0	33.0	36.0	46.0	55.0	70.0	80.0	95.0	110.0	46.0	50.0	65.0	80.0	95.0	110.0	123.0	-	-
Across Corners Diameter 'B'	26.6	30.0	33.3	36.6	40.0	51.0	61.0	77.6	89.0	105.0	122.0	51.0	55.4	72.1	88.6	105.0	122.0	138.0	-	-
Male Thread Length 'C'	15.0	15.0	15.0	15.0	15.0	15.0	15.0	15.0	15.0	15.0	19.0	16.0	16.0	23.0	25.0	25.0	29.0	39.0	-	-
Female Thread Length 'E'	20.0	20.0	20.0	20.0	20.0	20.0	21.0	21.0	25.0	25.0	29.0	22.0	22.0	22.0	29.0	35.0	35.0	39.0	-	-
Protrusion Length 'F'	5.0	5.0	5.0	5.0	5.0	5.0	6.0	6.0	10.0	10.0	10.0	6.0	6.0	6.0	10.0	10.0	10.0	-	-	-

To obtain CMP 737 Adaptor & Reducer nominal dimensions, follow the steps below:-

- Step 1 - Select male thread by consulting the left hand column of table 'A'
- Step 2 - Select the female thread size by consulting column headings at the top of table 'A', and by cross referencing this with the selection in step 1, identify the key reference number prefixed 'A' for Adaptor and 'R' for reducer.
- Step 3 - Using this key reference number, please refer to the corresponding dimensions in Table 'B'.

Please note that the data in tables 'A' and 'B' above include Adaptors and Reducers which are certified for use in Hazardous Areas. Dimension data for other Industrial versions is available from CMP Products on request.

777 SERIES Insulated Adaptors

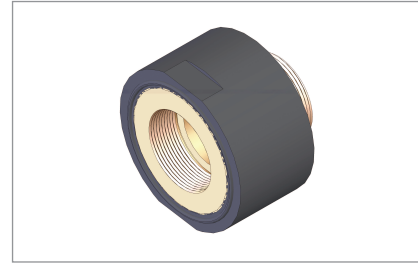
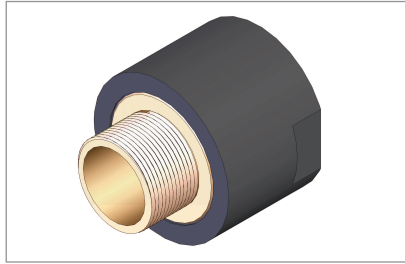

Insulated Adaptor Type 777 with Flameproof Ex d IIC & Increased Safety Ex e II forms of protection.

The CMP Type 777 Insulated Adaptor allows the Metallic Cable Gland, and ultimately the cable armour, to be effectively isolated from the equipment. The use of these Adaptors has proven to be an essential precaution in areas where electromagnetic 'noise' and circulating eddy currents 'stray' around any vulnerable cable system. Particularly relevant in Power Plants and in areas where highly sensitive instrumentation circuits are relied upon for interference free safety critical operations, the cable armour can still be connected to ground externally with the use of an earth tag fitted between the cable gland and insulated adaptor. This allows the user to design his system around a single point earthing strategy and allows the operator to perform tests on the earth circuit without disconnection of the elements installed. A General Purpose Industrial version is also available.

CMP 777 Insulated Adaptors are available in Brass, Aluminium or Stainless Steel and can be supplied for both Industrial and Hazardous Area applications, with Ex 'd' & Ex 'e' Component Approval.

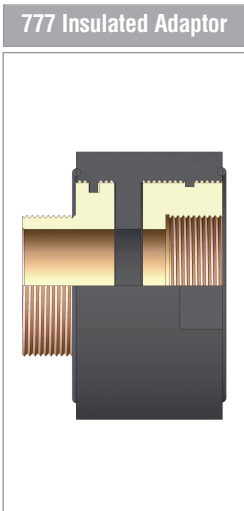

777 Insulated Adaptor		Technical Data	
Type	777		
Design Specification	BS 6121: Part 1: 1989, EN 50262:1999		
ATEX Certification Detail	SIRA 05 ATEX 1233U		
Code of Protection Category	ATEX (Ex) II 2 GD Ex d IIC & Ex e II Component, Zone 1, Zone 2, Zone 21, & Zone 22 - Gas Groups IIA, IIB, IIC		
IECEx Certification Detail	IECEx SIR 05.0044U		
Code of Protection Category	Ex d IIC / Ex e II / Ex tD A21 IP6X		
Compliance Standards	EN 60079-0, EN 60079-1, EN 60079-7, EN 61241-0, EN 61241-1, IEC 60079-0, IEC 60079-1, IEC 60079-7, IEC 61241-0, IEC 61241-1		
Continuous Operating Temperatures	-20°C to + 60°C		
Ingress Protection Rating	IP68		
Materials	Brass, Nickel Plated Brass, Aluminium, Stainless Steel		
Accessories Included	Integral Entry Thread 'O' Ring Seal		
Optional Accessories	Locknut, Serrated Washer		

Product Selection Table *						
Ordering Reference	Male Thread Size	Minimum Thread Length	Female Thread Size	Maximum Bore Diameter	Nominal Protrusion Length	Overall Envelope Diameter
777DM2M2	M20 X 1.5	15	M20 X 1.5	14.3	36.1	40.0
777DM3M3	M25 X 1.5	15	M25 X 1.5	20.3	40.5	57.0
777DM4M4	M32 X 1.5	15	M32 X 1.5	26.8	40.6	57.0
777DM5M5	M40 X 1.5	15	M40 X 1.5	32.7	40.9	76.0
777DM6M6	M50 X 1.5	15	M50 X 1.5	44.6	41.2	76.0
777DM7M7	M63 X 1.5	15	M63 X 1.5	56.5	57.2	100.0
777DM8M8	M75 X 1.5	15	M75 X 1.5	65.2	57.2	100.0

All dimensions shown are in millimetres unless otherwise stated

Marked with ATEX certification details as standard. Alternative certification marking shown in the table below can be applied if requested at the time of ordering.

Additional Approvals	
GOST R Certificate Number	POCC GB.ГБ05.В01912
CSA Approval Certificate	1055233 Class I ABCD, Class II EFG, IP68 TYPE 4X Exd / Ex e IIC

Note* : Other Thread Variations available on request. Please refer to ordering guide tables on page 161 for reference definitions

747 SERIES Stopper Plugs

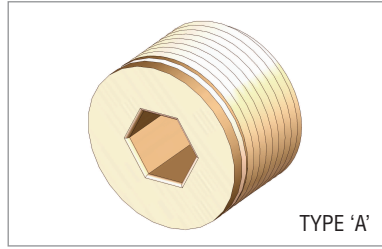

TYPE 'A'

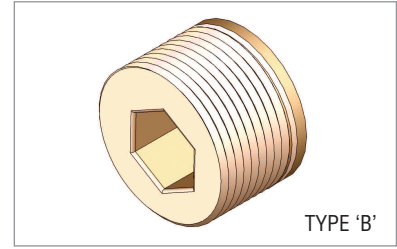

TYPE 'B'

Stopper Plug Type 747 with Flameproof Ex d IIC form of protection, with and without Tamper-proof facility.

The CMP Type 747 range of Flameproof Ex d Stopper Plugs is designed to provide a permanent or temporary means of blanking unused cable entry holes in Flameproof enclosures enabling the equipment to be safely deployed in the hazardous area. A General Purpose Industrial version is also available.

Always inserted from the outside of the enclosure, these Stopper Plugs are available with both external (Type A) and internal (Type B) Allen Key facility. The 747 Type B Stopper Plug is considered as tamper-proof since it can only be removed from the inside, after the equipment has been de-energised and the terminal chamber cover removed.

CMP Type 747 Stopper Plugs are available in Brass, Aluminium, Stainless Steel or Nylon (Exe) and can be supplied for both Industrial and Hazardous Area applications, with a variety of thread forms and sizes, including NPT. Please refer to Table 'D' on page 161 for further information on these options.

Technical Data	
Type	747 (Type A & Type B)
Design Specification	BS 6121: Part 1: 1989, EN 50262:1999
ATEX Certification Detail	SIRA 01 ATEX 1284U, SIRA 02 ATEX 1003X
Code of Protection Category	ATEX II 2 GD Ex d IIC & Ex e II Component & Equipment, Zone 1, Zone 2, Zone 21, & Zone 22 - Gas Groups IIA, IIB, IIC ATEX IM 2 Ex d I & Ex e I
IECEX Certification Detail	IECEX SIR07.0056U
Code of Protection Category	Ex d I / Ex e I / Ex d IIC / Ex e II / Ex tD A21 IP6X
Compliance Standards	EN 60079-0, EN 60079-1, EN 60079-7, EN 61241-1, IEC 60079-0, IEC 60079-1, IEC 60079-7, IEC 61241-1
Continuous Operating Temperatures	-60°C to +200°C (-20°C to +60°C Nylon version)
Ingress Protection Rating	IP66
Materials	Brass, Nickel Plated Brass, Aluminium, Stainless Steel, Nylon

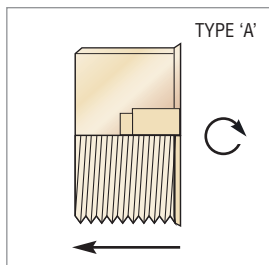

Ex 'd' Recessed
Stopper Plug Type 'A'

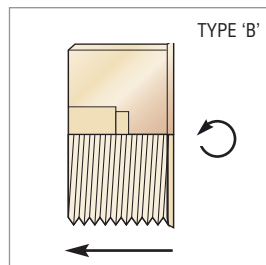

Ex 'd' Recessed
Stopper Plug Type 'B'

HOW TO ORDER *

e.g. 747 - F - A - M - M - 3 - 1
= Ex d - Type A - M25 - Aluminium

Note: For Tamper Proof Type B Stopper Plugs please substitute the letter A with the letter B in the Ordering Reference list opposite.

Standard Product Selection Table *

Ordering Reference	Thread Size	Minimum Thread Length	Allen Key Size A/F
747-F-A-M-1	M16 X 1.5	15	M8
747-F-A-M-2	M20 X 1.5	15	M10
747-F-A-M-3	M25 X 1.5	15	M10
747-F-A-M-4	M32 X 1.5	15	M10
747-F-A-M-5	M40 X 1.5	15	M10
747-F-A-M-6	M50 X 1.5	15	M10
747-F-A-M-7	M63 X 1.5	15	M14
747-F-A-M-8	M75 X 1.5	15	M14
747-F-A-M-9	M90 X 2	15	M14
747-F-A-M-10	M100 X 2	15	M14

All dimensions shown are in millimetres unless otherwise stated

Marked with ATEX certification details as standard. Alternative certification marking shown in the table below can be applied if requested at the time of ordering.

Additional Approvals	
Gost Ex Approval Certificate	POCC GB.ГE05.B01367, POCC GB.ГE05.B01369
CSA Approval Certificate	1055233 Class I ABCD, Class II EFG, IP68 TYPE 4X Ex d IIC
UL Listing file reference	EBNV.E214221 Class I ABCD, Class II EFG, & Class III

Note*: Other Thread Variations available on request. Please refer to ordering guide tables on page 161 for reference definitions

757 SERIES Stopper Plugs

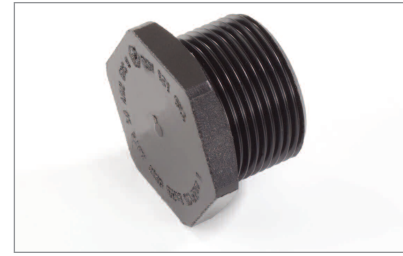
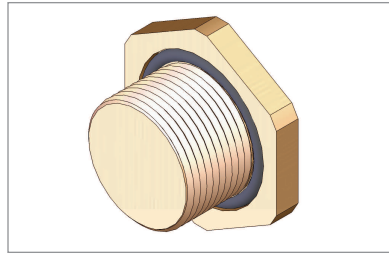

Stopper Plug Type 757 with Flameproof Ex d IIC & Increased Safety Ex e II forms of protection

The CMP Type 757 range of Stopper Plugs is designed to provide a permanent or temporary means of blanking unused cable entry holes in Flameproof and Increased Safety enclosures, enabling the equipment to be safely deployed in the hazardous area. The 757 range of Stopper Plugs is produced with a Hexagon Head, making it possible to install or remove with either an open ended or ring type spanner or wrench.

A General Purpose Industrial version is also available.

The CMP Type 757 Stopper Plug design allows for the addition of an entry thread sealing washer, which is available as an optional extra. Alternatively, this is also available with an optional Integral Entry Thread 'O' Ring seal.

CMP Type 757 Stopper Plugs are available in Brass, Aluminium, Stainless Steel or Nylon (Ex e), and can be supplied for both Industrial and Hazardous Area applications, in a variety of thread forms and sizes. Please refer to table 'D' on page 161 for further information on these options.

Technical Data	
Type	757
Design Specification	BS 6121: Part 1: 1989, EN 50262:1999
ATEX Certification Detail	SIRA 01 ATEX 1284U, SIRA 02 ATEX 1003X
Code of Protection Category	ATEX $\text{Ex} \text{II} 2 \text{GD} \text{Ex d IIC} \& \text{Ex e II}$ Component & Equipment, Zone 1, Zone 2, Zone 21, & Zone 22 - Gas Groups IIA, IIB, IIC ATEX $\text{Ex} \text{IM} 2 \text{Ex d I} \& \text{Ex e I}$
IECEX Certification Detail	IECEX SIR07.0056U
Code of Protection Category	Ex d I / Ex e I / Ex d IIC / Ex e II / Ex tD A21 IP6X
Compliance Standards	EN 60079-0, EN 60079-1, EN 60079-7, EN 61241-1, IEC 60079-0, IEC 60079-1, IEC 60079-7, IEC 61241-1
Continuous Operating Temperatures	-60°C to +200°C (Metallic), -20°C to +60°C (Nylon)
Ingress Protection Rating	IP66 or IP68 when fitted with a CMP 'O' Ring or Entry Thread Sealing Washer
Optional Accessories	Locknut, Serrated Washer, Earth Tag, Entry Thread Sealing Washer
Materials	Brass, Nickel Plated Brass, Aluminium, Stainless Steel, Nylon.

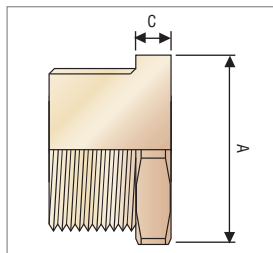

757 Series Stopper Plug

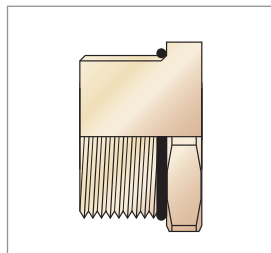

757 Series Stopper Plug with optional 'O' ring

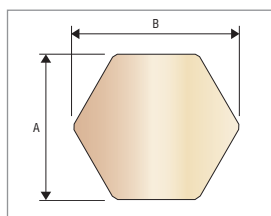

Stopper Plug end view

Product Selection Table *					
Ordering Reference	Thread Size	Minimum Thread Length	Across Flats 'A'	Across Corners Diameter 'B'	Protrusion Length 'C'
757-D-M-1	M16 X 1.5	15	24.0	26.0	5.0
757-D-M-2	M20 X 1.5	15	24.0	26.0	5.0
757-D-M-3	M25 X 1.5	15	30.0	33.0	5.0
757-D-M-4	M32 X 1.5	15	36.0	40.0	5.0
757-D-M-5	M40 X 1.5	15	46.0	51.0	6.0
757-D-M-6	M50 X 1.5	15	55.0	61.0	6.0
757-D-M-7	M63 X 1.5	15	70.0	78.0	6.0
757-D-M-8	M75 X 1.5	15	80.0	89.0	6.0
757-D-M-9	M90 X 2	15	95.0	106.0	6.0
757-D-M-10	M100 X 2	15	110.0	123.0	6.0

All dimensions shown are in millimetres unless otherwise stated

HOW TO ORDER *
e.g. 757 - E - M - 2 - 5
= Ex E - M20 - Nickel Plated Brass

Note: For Integral Entry Thread 'O' Ring Seal option please add the letter 'R' after the form of protection in the Ordering Reference list opposite, e.g. 757-D-R-M-3

Marked with ATEX certification details as standard. Alternative certification marking shown in the table below can be applied if requested at the time of ordering.

Additional Approvals	
Gost Ex Approval Certificate	POCC GB.ГБ 05.B01367, POCC GB.ГБ 05.B01369
CSA Approval Certificate	1055233 Ex e II, IP68, Type 4X
UL Listing file reference	EBNV.E214221 Class I ABCD, Class II EFG & Class III

Note * : Other Thread Variations available on request. Please refer to ordering guide tables on page 161 for reference definitions

767 SERIES Stopper Plugs

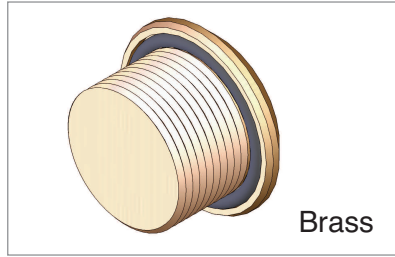

Brass



Nylon

Stopper Plug Type 767 with Flameproof Ex d I, Ex d IIC & Increased Safety Ex e I, Ex e II forms of protection

The CMP Type 767 range of Stopper Plugs is designed to provide a permanent or temporary means of blanking unused cable entry holes in Flameproof and Increased Safety enclosures, enabling the equipment to be safely deployed in the hazardous area. The 767 range of Stopper Plugs is produced with a Dome Head as standard, and is equipped with an Allen Key recess making it impossible to remove with a standard spanner or wrench.

A General Purpose Industrial version is also available.

The CMP Type 767 Stopper Plug design allows for the addition of an entry thread sealing washer, which is available as an optional extra. Alternatively, this is also available with an optional Integral Entry Thread 'O' Ring seal.

CMP Type 767 Stopper Plugs are available in Brass, Aluminium, Stainless Steel or Nylon (Ex e), can be supplied for both Industrial and Hazardous Area applications, and can be supplied in a variety of thread forms and sizes. Please refer to Table 'D' on page 161 for further information on these options.

Technical Data	
Type	767
Design Specification	BS 6121: Part 1: 1989, EN 50262:1999
ATEX Certification Detail	SIRA 01 ATEX 1284U, SIRA 01 ATEX 1003
Code of Protection Category	ATEX (Ex) II 2 GD Ex d IIC & Ex e II Component & Equipment, Zone 1, Zone 2, Zone 21, & Zone 22 - Gas Groups IIA, IIB, IIC ATEX (Ex) I M2 Ex d I & Ex e I
IECEX Certification Detail	IECEX SIR07.0056U
Code of Protection Category	Ex d I / Ex e I / Ex d IIC / Ex e II / Ex tD A21 IP66
Compliance Standards	EN 60079-0, EN 60079-1, EN 60079-7, EN 61241-1, IEC 60079-0, IEC 60079-1, IEC 60079-7, IEC 61241-1
Continuous Operating Temperatures	-60°C to +200°C (Metallic), -20°C to +60°C (Nylon)
Ingress Protection Rating	IP66 or IP68 when fitted with a CMP 'O' Ring or Entry Thread Sealing Washer
Optional Accessories	Locknut, Serrated Washer, Earth Tag, Entry Thread Sealing Washer
Materials	Brass, Nickel Plated Brass, Aluminium, Stainless Steel, Nylon.

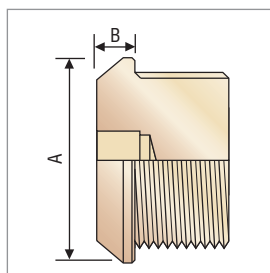

767 Series Stopper Plug

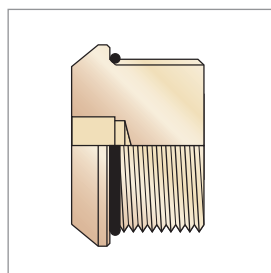

767 Series Stopper Plug with optional 'O' ring

HOW TO ORDER *

e.g. 767 - D - M - 2 - 4
= Dual Certified Ex d & Ex e - M20 - Stainless Steel

Note: For Integral Entry Thread 'O' Ring Seal option please use the letter 'R' after the form of protection in the Ordering Reference list opposite.

Product Selection Table *					
Ordering Reference	Thread Size	Minimum Thread Length	Head Diameter 'A'	Protrusion Length 'B'	Allen Key Size A/F
767-D-M-1	M16 X 1.5	15	23.0	5.0	M8
767-D-M-2	M20 X 1.5	15	27.0	5.0	M10
767-D-M-3	M25 X 1.5	15	30.0	5.0	M10
767-D-M-4	M32 X 1.5	15	36.0	5.0	M10
767-D-M-5	M40 X 1.5	15	46.0	5.0	M10
767-D-M-6	M50 X 1.5	15	56.0	5.0	M10
767-D-M-7	M63 X 1.5	15	70.0	5.0	M14
767-D-M-8	M75 X 1.5	15	80.0	5.0	M14
767-D-M-9	M90 X 2	15	95.0	5.0	M14
767-D-M-10	M100 X 2	15	110.0	5.0	M14

All dimensions shown are in millimetres unless otherwise stated

Marked with ATEX certification details as standard. Alternative certification marking shown in the table below can be applied if requested at the time of ordering.

Additional Approvals	
Gost Ex Approval Certificate	POCC GB.ГБ05.B01367, POCC GB.ГБ05.B01369
CSA Approval Certificate	1055233 Class I ABCD, IP68, TYPE 4X Ex d / Ex e IIC
UL Listing file reference	EBNV.E214221 Class I ABCD, Class II EFG, & Class III

Note * : Other Thread Variations available on request. Please refer to ordering guide tables on page 161 for reference definitions

787 SERIES

90° Adaptors

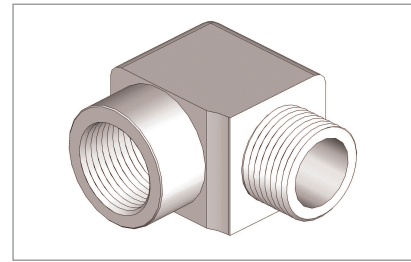
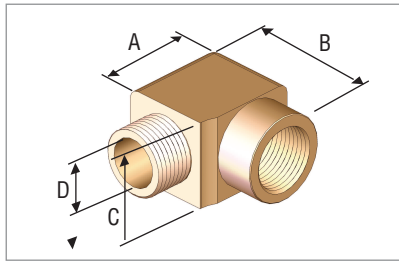

Right Angled Adaptor Type 787 with Flameproof Ex d IIC & Increased Safety Ex e II forms of protection

The CMP Type 787 Right Angled Adaptor is designed to protect cables when installed in confined spaces where the cable may otherwise be subject to excessive bending stress, and offers a means of connection where the cable cannot be installed in the usual perpendicular fashion. A General Purpose Industrial version is also available.

These Right Angled Adaptors are available with Male or Female connection threads and can also be supplied with thread conversion between the forward and rear threads to either a reduced size or a different thread type, e.g. Metric to NPT, or NPT to Metric. Please refer to Table 'D' on page 161 for further information on these options.

The CMP Type 787 Right Angled Adaptors are available in Brass, Aluminium or Stainless Steel and can be supplied for both Industrial and Hazardous Area applications, with Ex d & Ex e Component Approval.

TECHNICAL DATA	
Type	787
Design Specification	BS 6121: Part 1: 1989, EN 50262:1999
ATEX Certification Detail	SIRA 01 ATEX 1284U
Code of Protection Category	ATEX II 2 GD Ex d IIC & Ex e II Component, Zone 1, Zone 2, Zone 21, & Zone 22 - Gas Groups IIA, IIB, IIC ATEX IM 2 Ex d I & Ex e I
IECEX Certification Detail	IECEX SIR07.0055U
Code of Protection Category	Ex d I / Ex e I / Ex d IIC / Ex e II / Ex tD A21 IP6X
Compliance Standards	EN 60079-0, EN 60079-1, EN 60079-7, EN 61241-1, IEC 60079-0, IEC 60079-1, IEC 60079-7, IEC 61241-1
Continuous Operating Temperatures	-60°C to + 200°C
Ingress Protection Rating	IP66 or IP68 when fitted with a CMP 'O' Ring or Entry Thread Sealing Washer
Materials	Brass, Nickel Plated Brass, Aluminium, Stainless Steel
Optional Accessories	Locknut, Serrated Washer, Earth Tag, Entry Thread Sealing Washer

Product Selection Table *								
Ordering Reference	Male Forward Thread	Minimum Thread Length	Bore Diameter 'D'	Female Rear Thread Size	Protrusion Length 'A'		Width 'B'	Installation Torque (Nm)
					Male to Female Version	Female to Male Version		
787DM2M2	M20 X 1.5	15	14.3	M20 X 1.5	31.0	37.0	43.0	7
787DM3M3	M25 X 1.5	15	20.3	M25 X 1.5	41.0	67.0	45.0	10
787DM4M4	M32 X 1.5	15	26.8	M32 X 1.5	49.0	69.0	52.0	15
787DM5M5	M40 X 1.5	15	32.7	M40 X 1.5	62.0	74.0	65.0	25
787DM6M6	M50 X 1.5	15	44.6	M50 X 1.5	82.0	96.0	60.0	30
787DM7M7	M63 X 1.5	15	48.0	M63 X 1.5	90.0	102.0	84.0	45
787DM8M8	M75 X 1.5	15	61.0	M75 X 1.5	95.0	108.0	95.0	45
787DM9M9	M90 X 1.5	15	73.0	M90 X 1.5	96.0	110.0	111.0	45
787DM10M10	M100 X 1.5	15	88.0	M100 X 1.5	100.0	120.0	125.0	45

All dimensions shown are in millimetres unless otherwise stated

Marked with ATEX certification details as standard. Alternative certification marking shown in the table below can be applied if requested at the time of ordering.

Additional Approvals	
IEC Approval Certificate	SIRA 05 Y 1089U
Gost Ex Approval Certificate	POCC GB.ГБ.05.В01367, POCC GB.ГБ.05.В01369
CSA Approval Certificate	1055233 Class I ABCD, Class II EFG, IP68, TYPE 4X Ex d / Ex e IIC

Note: Versions with Male Parallel forward threads are, as an option, also available with an integral 'O' Ring Seal. For such options please add the suffix letter 'R' after the type number (787) in the ordering reference above, e.g 787RDM2M2.

780 SERIES Unions

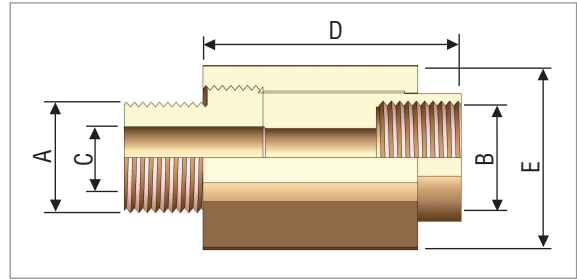
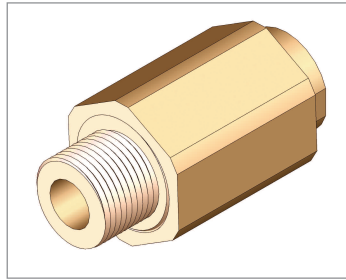

Union Type 780 with Flameproof Ex d IIC & Increased Safety Ex e II forms of protection.

The CMP Type 780 Metallic Union is designed to allow connection of rigid and flexible conduit, or terminated cable glands, to any fixed equipment. The 780 Union provides a running connection by means of an integral coupling arrangement that eliminates the need to rotate the conduit, or cable, or equipment to achieve a correct termination. The ease of installation offered by the 780 Union consequently makes the process of removing the conduit or other terminated cable entry device from the equipment a simple, fast and effective one.

Available in Brass, Aluminium or Stainless Steel these Unions are approved for use in conjunction with Ex d and Ex e certified equipment and cable entry devices, and can also be supplied with thread conversion between the forward and rear threads to either a reduced size or a variety of different thread types, e.g. Metric to NPT, or NPT to Metric. Please refer to Table D on page 161 for further information on these options.

A General Purpose Industrial version is also available.

Technical Data	
Type	780
Design Specification	BS 6121: Part 1: 1989
ATEX Certification Detail	SIRA 01 ATEX 1284U
Code of Protection Category	ATEX $\text{Ex II 2 GD Ex d IIC \& Ex e II Component, Zone 1, Zone 2, Zone 21, \& Zone 22 - Gas Groups IIA, IIB, IIC}$
IECEX Certification Detail	IECEX SIR07.0051U
Code of Protection Category	Ex d IIC / Ex e II / Ex tD A21 IP6X
Compliance Standards	EN 60079-0, EN 60079-1, EN 60079-7, EN 61241-1, IEC 60079-0, IEC 60079-1, IEC 60079-7, IEC 61241-1
Continuous Operating Temperature	-60°C to +200°C
Ingress Protection Rating	IP66 or IP68 when fitted with a CMP 'O' Ring or Entry Thread Sealing Washer
Materials	Brass, Nickel, Plated Brass, Aluminium, Stainless Steel
Optional Accessories	Locknut, Serrated Washer, Earth Tag, Entry Thread Sealing Washer

Product Selection Table *								
Ordering Reference	Male Forward Thread Size 'A'	Minimum Thread Length	Female Rear Thread Size 'B'	Bore Diameter 'C'	Protrusion Length 'D'	Dimension 'E'		Installation Torque (Nm)
						A/F	A/C	
780DM1M1	M16 X 1.5	15	M16 X 1.5	11.0	45.6	30.0	33.0	7
780DM2M2	M20 X 1.5	15	M20 X 1.5	14.3	45.6	30.0	33.0	7
780DM3M3	M25 X 1.5	15	M25 X 1.5	20.3	46.2	34.0	39.0	10
780DM4M4	M32 X 1.5	15	M32 X 1.5	26.8	46.7	41.0	47.0	15
780DM5M5	M40 X 1.5	15	M40 X 1.5	32.7	47.2	49.0	56.0	25
780DM6M6	M50 X 1.5	15	M50 X 1.5	44.6	47.1	60.0	69.0	30
780DM7M7	M63 X 1.5	15	M63 X 1.5	56.5	51.4	72.0	83.0	45
780DM8M8	M75 X 1.5	15	M75 X 1.5	68.5	56.2	84.0	97.0	45
780DM9M9	M90 X 2	15	M90 X 2	81.0	61.0	99.0	114.0	45
780DM10M10	M100 X 2	15	M100 X 2	91.3	66.2	113.0	130.0	45

All dimensions shown are in millimetres unless otherwise stated

Marked with ATEX certification details as standard. Alternative certification marking shown in the table below can be applied if requested at the time of ordering.

Additional Approvals	
Gost Ex Approval Certificate	POCC GB. ГБ 05.B01367, POCC GB. ГБ 05.B01369
CSA Approval Certificate	1055233 Class I ABCD, Class II EFG, IP68 TYPE 4X Ex d / Ex e IIC

Note : Versions with Male Parallel threads are, as an option, also available with an integral 'O' Ring seal. For such options please add the suffix letter 'R' after the type number (780) in the ordering reference above, e.g 780RDM2M2.

Note : * Please refer to ordering guide tables on page 161 for reference definitions.

797 SERIES

Adaptors

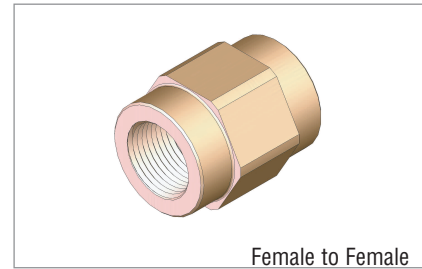
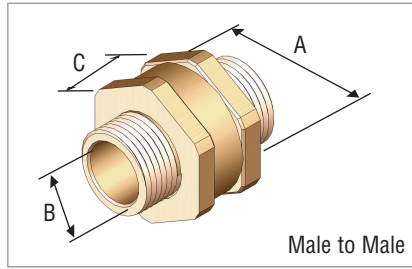

Male to Male & Female to Female Adaptor Type 797 with Flameproof Ex d I / Ex d IIC & Increased Safety Ex e I / Ex e II forms of protection.

The CMP Type 797 Male to Male and Female to Female Adaptor is designed to convert an existing enclosure aperture to the opposite male or female thread form. These Male to Male & Female to Female Adaptors can also be supplied with thread conversion between the two threads to either a reduced size or a different thread type, e.g. Metric to NPT, or NPT to Metric. Please refer to Table 'D' on page 161 for further information on these options. A General Purpose Industrial version is also available.

The CMP Type 797 Male to Male and Female to Female Adaptors are available in Brass, Aluminium or Stainless Steel and can be supplied for both Industrial and Hazardous Area applications, with Ex 'd' & Ex e Component and Equipment Approval.

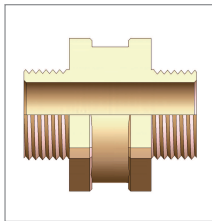

Male to Male

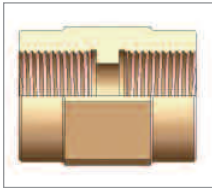

Female to Female

Technical Data	
Type	797
Design Specification	BS 6121: Part 1: 1989, EN 50262:1999
ATEX Certification Detail	SIRA 01 ATEX 1284U, SIRA 02 ATEX 1003X
Code of Protection Category	ATEX Ex II 2 GD Ex d IIC & Ex e II Component & Equipment, Zone 1, Zone 2, Zone 21, & Zone 22 - Gas Groups IIA, IIB, IIC ATEX Ex IM 2 Ex d I & Ex e I
IECEx Certification Detail	IECEx SIR07.0052U
Code of Protection Category	Ex d I / Ex e I / Ex d IIC / Ex e II / Ex tD A21 IP6X
Compliance Standards	EN 60079-0, EN 60079-1, EN 60079-7, EN 61241-1, IEC 60079-0, IEC 60079-1, IEC 60079-7, IEC 61241-1
Continuous Operating Temperatures	-60°C to + 200°C
Ingress Protection Rating	IP66 or IP68 when fitted with a CMP 'O' Ring or Entry Thread Sealing Washer
Materials	Brass, Nickel Plated Brass, Aluminium, Stainless Steel
Optional Accessories	Locknut, Serrated Washer, Earth Tag, Entry Thread Sealing Washer

Product Selection Table (Female to Female)*								
Ordering Reference	Male / Female Forward Thread Size	Minimum Thread Length	Male / Female Thread	Across Flats Dimension		Bore Diameter 'B'	Protrusion Length 'C'	Installation Torque (Nm)
				A/F	A/C			
797DM1FM1F	M16 X 1.5	15	M16 X 1.5	24.0	26.0	10.0	26.0	7
797DM2FM2F	M20 X 1.5	15	M20 X 1.5	24.0	26.0	14.3	26.0	7
797DM3FM3F	M25 X 1.5	15	M25 X 1.5	30.0	33.0	20.3	26.0	10
797DM4FM4F	M32 X 1.5	15	M32 X 1.5	36.0	40.0	26.8	26.0	15
797DM5FM5F	M40 X 1.5	15	M40 X 1.5	48.0	46.0	32.7	26.0	25
797DM6FM6F	M50 X 1.5	15	M50 X 1.5	55.0	61.0	44.6	26.0	30
797DM7FM7F	M63 X 1.5	15	M63 X 1.5	70.0	78.0	56.5	26.0	45
797DM8FM8F	M75 X 1.5	15	M75 X 1.5	80.0	89.0	68.5	26.0	45
797DM9FM9F	M90 X 1.5	15	M90 X 2	95.0	106.0	81.0	26.0	45
797DM10FM10F	M100 X 2	15	M100 X 2	110.0	123.0	91.0	36.0	45

All dimensions shown are in millimetres unless otherwise stated

Marked with ATEX certification details as standard. Alternative certification marking shown in the table below can be applied if requested at the time of ordering.

Additional Approvals	
IEC Approval Certificate	SIRA 05 Y 1089U
Gost Ex Approval Certificate	POCC GB.ГБ05.В01367, POCC GB.ГБ05.В01369
CSA Approval Certificate	1055233 Class I ABCD, Class II EFG, IP68, TYPE 4X, Ex d / Ex e IIC

Note: For Male to Male versions please substitute (x2) the letter F with a letter M in the ordering references above. Versions with Male to Male Parallel threads are, as an option, also available with an integral 'O' Ring Seal. For such options please add the suffix letter 'R' after the type number (797) in the ordering reference above, e.g. 797RDM2MM2M

ACCESSORIES

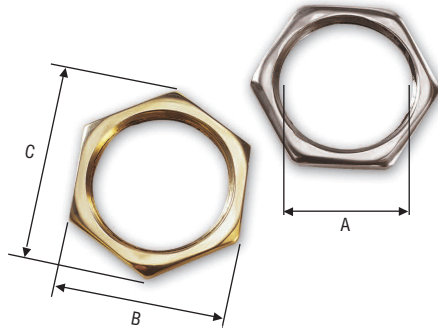

LOCKNUTS

Brass Locknuts are the recommended items used in securing brass cable glands, unions, adaptors, reducers, and stopper plugs to a gland plate or into equipment.

Zinc Plated Mild Steel locknuts are a cost effective alternative to brass locknuts and should be used only in dry, low humidity conditions.

Aluminium locknuts are recommended when installing CMP Aluminium Cable Glands to prevent the electrolytic action of galvanic corrosion which can occur when dissimilar metals are coupled together.

Note: Alternative materials are also available. Please refer to Table 'E' on page 161 for ordering reference numbers, e.g 20LN4 for M20 Stainless Steel Locknut, 050NPTLN4 for 1/2" NPT Stainless Steel Locknut.

METRIC - LOCKNUTS

Ordering Reference (Brass)	Thread Diameter 'A'	Minimum Thickness	Across Flats Dimension 'B'	Across Corners Diameter 'C'
16LN	M16 X 1.5	3.2	22.0	25.4
20LN	M20 X 1.5	3.2	24.0	28.6
25LN	M25 X 1.5	3.2	30.0	35.0
32LN	M32 X 1.5	3.2	36.0	42.0
40LN	M40 X 1.5	4.8	46.0	53.0
50LN	M50 X 1.5	6.3	55.0	64.0
63LN	M63 X 1.5	6.3	70.0	81.0
75LN	M75 X 1.5	6.3	80.0	98.0
90LN	M90 X 2	9.5	108.0	125.0
100LN	M100 X 2	9.5	122.0	141.5

All dimensions shown are in millimetres unless otherwise stated

NPT - LOCKNUTS

Ordering Reference (Brass)	Thread Diameter 'A'	Minimum Thickness	Across Flats Dimension 'B'	Across Corners Diameter 'C'
050NPTLN	1/2" NPT	4.75	27.0	29.3
075NPTLN	3/4" NPT	4.75	33.0	35.8
100NPTLN	1" NPT	4.5	41.0	45.0
125NPTLN	1 1/4" NPT	4.75	50.0	53.4
150NPTLN	1 1/2" NPT	5.1	60.0	69.0
200NPTLN	2" NPT	5.1	70.0	80.2
250NPTLN	2 1/2" NPT	10.0	79.0	90.5
300NPTLN	3" NPT	10.0	108.0	123.0
350NPTLN	3 1/2" NPT	11.5	114.0	131.0

All dimensions shown are in millimetres unless otherwise stated

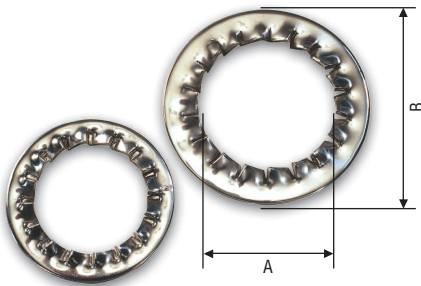

SERRATED WASHERS

Available in Stainless Steel as standard, these "shake-proof" Serrated Washers fitted internally to the equipment and before a locknut act as an anti-vibration device to prevent the cable gland or other cable entry device and locknut arrangement from inadvertently loosening in service.

Note: Alternative materials are also available. Please refer to Table 'E' on page 161 for ordering reference numbers, e.g 20SW4 for M20 Stainless Steel Serrated Washer, 050NPTSW4 for 1/2" NPT Stainless Steel Serrated Washer.

METRIC - SERRATED WASHERS

Ordering Reference (Plated Steel)	Reference Diameter 'A'	Minimum Thickness	External Diameter 'B'
16SW	M16	3.3	25.4
20SW	M20	3.7	32.0
25SW	M25	3.7	40.0
32SW	M32	3.7	44.0
40SW	M40	3.7	59.0
50SW	M50	3.7	80.0
63SW	M63	4.5	100.0
75SW	M75	5.0	112.0
90SW	M90	5.0	120.0
100SW	M100	6.3	150.0

All dimensions shown are in millimetres unless otherwise stated

NPT - SERRATED WASHERS

Ordering Reference (Plated Steel)	Reference Diameter 'A'	Minimum Thickness	External Diameter 'B'
050NPTSW	1/2" NPT	3.7	32.0
075NPTSW	3/4" NPT	3.7	40.0
100NPTSW	1" NPT	3.7	44.0
125NPTSW	1 1/4" NPT	3.7	59.0
150NPTSW	1 1/2" NPT	3.7	80.0
200NPTSW	2" NPT	4.5	100.0
250NPTSW	2 1/2" NPT	5.0	112.0
300NPTSW	3" NPT	5.0	120.0
350NPTSW	3 1/2" NPT	6.3	150.0

All dimensions shown are in millimetres unless otherwise stated

ACCESSORIES

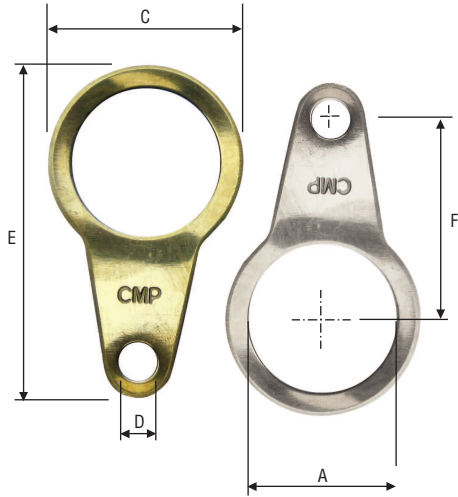

EARTH TAGS

CMP slip on earth tags, installed between the cable gland and equipment, provide an earth bond connection as specified in BS6121:Part 5:1993 and also complies with category 'B' rating specified in BS EN 50262:1999. The following table of fault current ratings relates to CMP Brass Earth Tags.

CMP Earth Tag Size	Short Circuit Ratings Symmetrical Fault Current (kA) for 1 second
20	3.06
25	4.00
32	5.40
40	7.20
50	10.40
63	10.40
75	10.40

Note: Alternative materials are also available. Please refer to Table 'E' on page 161 for ordering reference numbers, e.g 20ET4 for M20 Stainless Steel Earth Tag, 050NPTET4 for 1/2" NPT Stainless Steel Earth Tag.

METRIC - EARTH TAGS

Ordering Reference (Brass)	Reference Diameter 'A'	Minimum Thickness	Nominal Diameter 'C'	Hole Size 'D'	Nominal Length 'E'	Nominal Centres 'F'
16ET	M16	1.5	25.4	M6	49.3	30.2
20ET	M20	1.5	27.1	M6	53.4	33.1
25ET	M25	1.5	35.1	M6	59.4	35.6
32ET	M32	1.5	45.2	M12	77.0	43.1
40ET	M40	1.5	53.7	M13	88.7	45.4
50ET	M50	1.5	65.2	M13	111.1	58.1
63ET	M63	1.5	82.6	M13	128.6	66.8
75ET	M75	1.5	95.4	M13	141.1	73.0
90ET	M90	1.5	114.2	M13	161.0	85.0
100ET	M100	1.5	126.0	M13	194.0	118.0

All dimensions shown are in millimetres unless otherwise stated

NPT - EARTH TAGS

Ordering Reference (Brass)	Reference Diameter 'A'	Minimum Thickness	Nominal Diameter 'C'	Hole Size 'D'	Nominal Length 'E'	Nominal Centres 'F'
050NPTET	1/2" NPT	1.5	27.1	M6	53.4	33.1
075NPTET	3/4" NPT	1.5	35.1	M6	59.4	35.6
100NPTET	1" NPT	1.5	45.2	M12	77.0	43.1
125NPTET	1 1/4" NPT	1.5	53.7	M13	88.7	45.4
150NPTET	1 1/2" NPT	1.5	65.2	M13	111.1	58.1
200NPTET	2" NPT	1.5	82.6	M13	128.6	66.8
250NPTET	2 1/2" NPT	1.5	95.4	M13	141.1	73.0
300NPTET	3" NPT	1.5	114.2	M13	161.0	85.0
350NPTET	3 1/2" NPT	1.5	126.0	M13	194.0	118.0

All dimensions shown are in millimetres unless otherwise stated



SHROUDS

CMP manufacture a range of push on shrouds which are used to minimise the risk of dirt or foreign substances gathering on the Cable Gland body, and/or point of cable to gland interface. Standard shrouds are produced in Black PVC and PCP. CMP LSF (Blue/Grey) shrouds are available from stock. Table below shows typical examples of CMP shrouds.

SHROUD REFERENCES

GLAND TYPE	20/16	20S	20	25	32	40	50S	50	63S	63	75S	75	90
BWL	PVC02	PVC04	PVC06	PVC09	PVC11	PVC13	PVC17	PVC20	PVC22	PVC25	PVC28	PVC30	PVC32
A2	PVC02	PVC04	PVC05	PVC09	PVC10	PVC13	PVC14	PVC17	PVC20	PVC22	PVC24	PVC26	PVC31
E1W	PVC02	PVC04	PVC06	PVC09	PVC11	PVC15	PVC18	PVC21	PVC23	PVC25	PVC28	PVC30	PVC32

COLOUR CODED SHROUDS

PVC, PCP & LSF shrouds are also manufactured in alternative colours including Red, Blue and White, to suit a wide variety of customer requirements, other colours are available.

ACCESSORIES

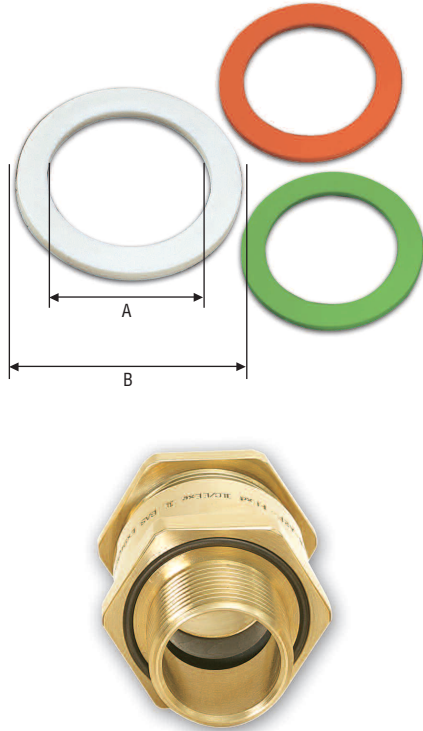

ENTRY THREAD SEALING WASHERS

To maintain the Ingress Protection rating between the equipment and cable gland it may be necessary to fit an Entry Thread Sealing Washer at the gland entry interface. For Explosion Protected equipment it is essential to maintain the integrity of the degree of Ingress Protection at which the equipment has been rated.

The need for a sealing washer will very much depend on the Ingress Protection rating and code of protection of the equipment and the type of entry holes available within that equipment.

For example when Ex e apparatus or terminal boxes which are permitted to have untapped through clearance holes it will be necessary to fit a sealing washer to ensure that the minimum IP54 requirement (for gas / vapour hazards) is met. Whereas other equipment having tapped entry holes may not require a sealing washer to maintain the rated integrity of the installation, or the minimum requirement for the specified form of protection.

The CMP Entry Thread Sealing Washers are produced in 2mm Thick White Nylon as standard which are recommended and meet the specified requirements of Shell's Offshore operations.

To verify the effectiveness of the CMP nylon entry sealing washers independent 3rd party tests to EN 60529 have been successfully conducted on Cable Gland at IP66, IP67 & IP68 levels of protection. CMP can therefore provide independent documentary evidence of such tests to the highest standards.

Red Fibre Washers can also be supplied to order but careful consideration should be given to their use in sub zero climates where absorption, freezing and cracking have been known to occur, ultimately impairing the degree of Ingress Protection attainable.

CMP also offers as an alternative, cable glands, adaptors, reducers, and stopper plugs with Integral Entry Thread 'O' Ring Seal, as pictured opposite.

WHITE METRIC ENTRY THREAD SEALING WASHERS

Ordering Reference	Reference Diameter 'A'	Minimum Thickness	External Diameter 'B'
16ETS2	M16	2.0	25.4
20ETS2	M20	2.0	28.6
25ETS2	M25	2.0	35.0
32ETS2	M32	2.0	44.5
40ETS2	M40	2.0	50.8
50ETS2	M50	2.0	65.0
63ETS2	M63	2.0	76.2
75ETS2	M75	2.0	95.0
90ETS2	M90	2.0	110.0

All dimensions shown are in millimetres unless otherwise stated

GREEN NPT ENTRY THREAD SEALING WASHERS

Ordering Reference	Reference Diameter 'A'	Minimum Thickness	External Diameter 'B'
050NPTETS	1/2" NPT	2.0	28.6
075NPTETS	3/4" NPT	2.0	35.0
100NPTETS	1" NPT	2.0	44.5
125NPTETS	1 1/4" NPT	2.0	50.8
150NPTETS	1 1/2" NPT	2.0	65.0
200NPTETS	2" NPT	2.0	76.2
250NPTETS	2 1/2" NPT	2.0	95.0
300NPTETS	3" NPT	2.0	110.0

All dimensions shown are in millimetres unless otherwise stated

To the best of our knowledge the information contained in this document is accurate at the time of going to print and CMP reserve the right to improve or modify any products illustrated without prior notification. CMP can not accept liability for any inaccuracies, errors or omissions that may exist. It is the customers responsibility to ensure that the product is suitable for the application.

All copyright herein is the property of CMP Products a division of British Engines Ltd and cannot be reproduced without the permission of CMP Products.

TYPICAL INSTALLATION CONFIGURATIONS

Note: The illustrations provided below are indicative of some of the common methods of installation configurations adopted. These are for informative guidance only and relevant site conditions along with any specified National or International Codes of practice must always take precedence. The accessories available offer a wide flexible approach in mounting, sealing and earthing connection provision. Selection and Installation according to the Engineering Specification may vary from these illustrations.

CABLE GLAND WITHOUT ADAPTOR

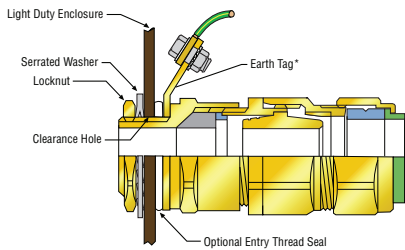

Parallel threaded gland through clearance hole. Earth via Earth Tag when specified

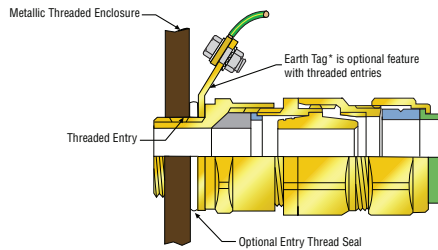

Parallel threaded gland into a threaded enclosure. Earth via the threads or Earth Tag if specified.

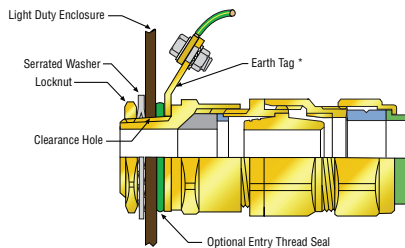

Taper threaded gland through clearance hole. Earth via earth tag when specified.

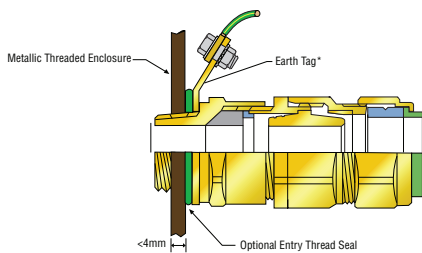

Tapered threaded gland into a threaded hole < 4mm. Earth via threads or an earth tag when specified.

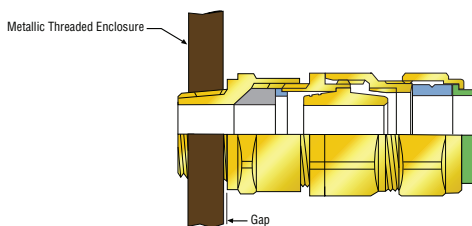

Tapered threaded gland into a threaded hole. Earth via entry thread when enclosure width is > greater than 4mm.

CABLE GLAND WITH ADAPTOR

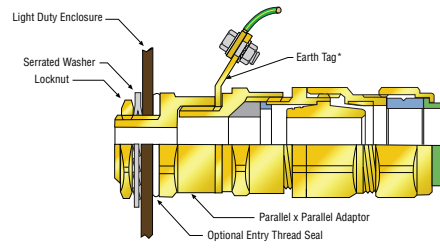

Parallel x Parallel adaptor through clearance hole. Earth via earth tag when specified.

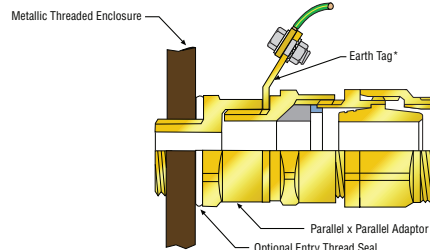

Parallel x Parallel adaptor through threaded hole. Earth via threads or earth tag when specified

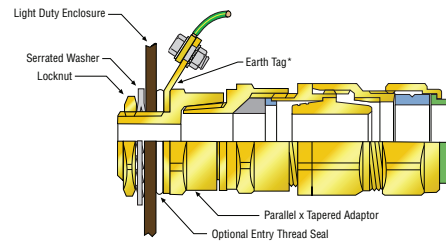

Parallel x Tapered or Tapered x Tapered adaptor through clearance hole. Earth via earth tag when specified

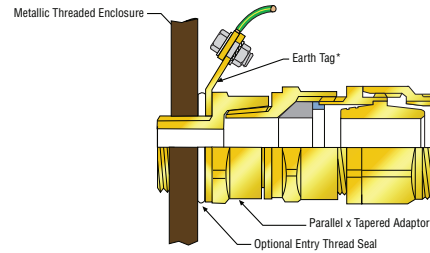

Parallel x Tapered adaptor through threaded hole. Earth via threads or earth tag when specified

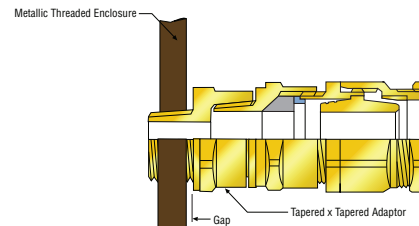

Taper x Taper adaptor through threaded hole. Earth via entry threads when enclosure is > 4mm.



MATERIAL & THREAD

Specification

MATERIALS
Brass Extruded bar to EN12168: 1998 Grade CuZn39Pb (CW614N) (Previously BS2874: 1986)
Stainless Steel to EN 10088-2:2005 Grade 316L (Previously BS970 Part 1: 1991)
Mild Steel to BS970 Part 1: 1996 Grade 220M07Pb
Aluminium Extruded bar to EN573-3:2003 Grade AW6082 & AW6262
Aluminium Castings to EN 1706: 1998 Grade ENAC42000. T6 (Previously BS1490 LM25. TF)
Brass Casting to BS1400: 1985 Grade HTB1

THREAD CONSTRUCTION STANDARDS	
Metric	ISO 965-1, ISO 965-3 medium fit (6g) for external threads
Imperial Conduit (ET)	BS 31 : 1940 (1979), Table A
PG	DIN 40430 : 1971
BSPP	BS 2779 : 1986 (1973) class A full form for external threads
BSPT	BS 21 : 1985 standard threads only as clause 5.4, gauging to clause 5.2 system A
ISO	ISO 7/1 : 1982, gauging to ISO 7/2 clause 6.3 for external threads
NPT	ANSI / ASME B1.20.1 - 1983 gauging to clause 8.1 for external threads
NPSM	ANSI / ASME B1.20.1 - 1983 gauging to clause 9 for external threads

ISO METRIC IEC 60423									PG DIN 40430								
THREAD REFERENCE	16	20	25	32	40	50	63	75	THREAD REFERENCE	PG7	PG9	PG11	PG13.5	PG16	PG21	PG29	PG36
THREAD SIZE	M16	M20	M25	M32	M40	M50	M63	M75	THREAD SIZE	PG7	PG9	PG11	PG13.5	PG16	PG21	PG29	PG36
THREAD PITCH	1.5	1.5	1.5	1.5	1.5	1.5	1.5	1.5	THREAD PITCH	1.27	1.41	1.41	1.41	1.41	1.59	1.59	1.59
THREAD PER INCH	16.93	16.93	16.93	16.93	16.93	16.93	16.93	16.93	THREAD PER INCH	20.00	18.00	18.00	18.00	18.00	16.00	16.00	16.00
MAJOR DIAMETER MAX	15.97	19.97	24.97	31.97	39.97	49.97	62.97	74.97	MAJOR DIAMETER MAX	12.5	15.2	18.6	20.4	22.5	28.3	37.0	47.0
CLEARANCE HOLE Ø MAX	16.5	20.5	25.5	32.5	40.5	50.5	63.5	75.5	CLEARANCE HOLE Ø MAX	13.0	15.7	19.1	20.9	23.0	28.8	37.5	47.5
NPT ANSI B1.20.1									BSP ISO R/7, BS2779 (BSPP,G,R,PF)								
THREAD REFERENCE	050	075	100	125	150	200	250	300	THREAD REFERENCE	050	075	100	125	150	200	250	300
THREAD SIZE	1/2"	3/4"	1"	1 1/4"	1 1/2"	2"	2 1/2"	3"	THREAD SIZE	1/2"	3/4"	1"	1 1/4"	1 1/2"	2"	2 1/2"	3"
THREAD PITCH	1.81	1.81	2.20	2.20	2.20	2.20	3.18	3.18	THREAD PITCH	1.81	1.81	2.31	2.31	2.31	2.31	2.31	2.31
THREAD PER INCH	14.00	14.00	11.5	11.5	11.5	11.5	8	8	THREAD PER INCH	14.00	14.00	11.00	11.00	11.00	11.00	11.00	11
MAJOR DIAMETER MAX	21.34	26.67	33.4	42.16	48.26	60.33	73.03	88.9	MAJOR DIAMETER MAX	20.96	26.44	33.25	41.91	47.80	59.61	75.18	87.88
CLEARANCE HOLE Ø MAX	21.84	27.17	33.9	42.66	48.76	60.83	73.53	89.4	CLEARANCE HOLE Ø MAX	21.46	26.94	33.75	42.41	48.30	60.11	75.68	88.387
NPS ANSI B1.20.1									BSPT ISO R/7, BS21 (BSPT,GK)								
THREAD REFERENCE	050	075	100	125	150	200	250	300	THREAD REFERENCE	050	075	100	125	150	200	250	300
THREAD SIZE	1/2"	3/4"	1"	1 1/4"	1 1/2"	2"	2 1/2"	3"	THREAD SIZE	1/2"	3/4"	1"	1 1/4"	1 1/2"	2"	2 1/2"	3"
THREAD PITCH	1.81	1.81	2.20	2.20	2.20	2.20	3.18	3.18	THREAD PITCH	1.81	1.81	2.31	2.31	2.31	2.31	2.31	2.31
THREAD PER INCH	14.00	14.00	11.50	11.50	11.50	11.50	8.00	8.00	THREAD PER INCH	14.00	14.00	11.00	11.00	11.00	11.00	11.00	11
MAJOR DIAMETER MAX	20.9	26.26	32.84	41.6	47.67	59.71	72.16	88.06	MAJOR DIAMETER MAX	20.96	26.44	33.25	41.91	47.80	59.61	75.18	87.88
CLEARANCE HOLE Ø MAX	21.3	26.76	33.34	42.1	48.17	60.21	72.66	88.56	CLEARANCE HOLE Ø MAX	21.46	26.94	33.75	42.41	48.30	60.11	75.68	88.387

CMP Products Terms & Conditions will apply to all sales orders unless otherwise contractually agreed. These can be obtained from CMP offices or online at www.cmp-products.com



XLPE OR EPR/SWA/PVC CABLES TO BS5467 : 1997 With Extruded Bedding and Circular/Shaped Stranded Copper Conductors 600/1000 Volts										
XLPE / EPR				CABLE GLAND/CLEAT TYPE & SIZE						
CABLE CONSTRUCTION				CABLE GLAND/CLEAT TYPE & SIZE						
Conductor C.S.A. (mm ²)	No. of Cores	Nominal Diameters (mm)		INDOOR	OUTDOOR	OUTDOOR	OUTDOOR	UNICLEAT	SINGLE BOLT CLAMP	TWO BOLT CLAMP
		Under Armour	Overall	BW Gland	CW Gland	E1W Gland	E1FW Gland			
				BW Kit	CW Kit					
1.5	2	8.1	12.5	20S	20S/16	20S/16	20S/16	0916	1013	-
	3	8.6	13.0							
	4	9.4	14.0							
	7	11.3	15.9	25	25	25	25	1522	1923	
	12	14.7	20.2							
	19	17.5	23.2							
	27	21.3	27.9							
37	23.8	30.6	32	32	32	32	2129	2327		
2.5	2	9.0	13.6	20S	20S	20S	20S	0916	1316	-
	3	9.5	14.1							
	4	10.4	15.0							
	7	12.5	17.1	20	20	20	20	1522	1619	
	12	16.7	22.4							
	19	20.0	26.6							
	27	23.9	30.7							
37	27.0	33.8	32	32	32	32	2129	1923		
4	2	10.1	14.7	20S	20S	20S	20S	0916	1316	-
	3	10.7	15.3							
	4	11.8	16.4							
	7	14.2	19.7	20	20	20	20	1522	1619	
	12	19.3	25.7							
	19	22.7	29.3							
	27	27.4	34.4							
37	31.2	39.2	32	32	32	32	2129	1923		
6	2	11.3	15.9	20S	20S	20S	20S	0916	1316	-
	3	12.0	16.6							
	4	13.2	18.7							
10	2	13.2	18.0	20	20	20	20	1522	1619	-
	3	14.0	19.5							
	4	15.6	21.1							
16	2	14.5	20.0	25	25	25	25	1522	1923	-
	3	15.5	21.2							
	4	17.2	22.9							
25	2	18.4	24.1	25	25	25	25	2129	2327	-
	3	20.1	26.7							
	4	22.3	28.9							
35	2	21.3	27.9	32	32	32	32	2129	2732	-
	3	22.8	29.6							
	4	25.3	32.1							
50	2	19.0	25.8	25	25	25	25	2129	2327	-
	3	21.7	28.5							
	4	25.0	32.0							
70	2	22.0	29.0	32	32	32	32	2839	2732	-
	3	25.2	32.2							
	4	29.5	37.7							
95	2	25.1	33.1	32	32	32	32	2839	3238	-
	3	28.8	37.0							
	4	33.3	41.7							
120	2	27.9	36.1	40	40	40	40	2839	3238	-
	3	32.0	40.4							
	4	37.5	47.1							
150	2	30.9	39.3	40	40	40	40	3852	3846	-
	3	35.9	45.5							
	4	41.6	51.4							
185	2	34.9	44.7	50S	50S	50S	50S	3852	3846	-
	3	40.0	49.8							
	4	46.4	56.6							
240	2	39.0	49.0	50	50	50	50	3852	3846	-
	3	44.9	55.1							
	4	52.6	63.0							
300	2	43.3	53.5	50	63S	63S	63S	-	-	-
	3	49.8	60.2							
	4	58.0	68.8							
400	2	48.4	59.0	63S	63S	63S	63S	-	-	-
	3	55.8	66.6							
	4	65.4	78.1							
				75	75	75	75			7683

Note : For Cables up to 35mm sq, Conductors are Circular Stranded and for cables 50mm sq and over, conductors are Shaped Stranded



PVC/SWA/PVC CABLES TO BS6346 : 1997														
With Extruded Bedding and Circular/Shaped Stranded Copper Conductors 600/1000 Volts														
PVC				CABLE GLAND/CLEAT TYPE & SIZE										
CABLE CONSTRUCTION				CABLE GLAND/CLEAT TYPE & SIZE										
Conductor C.S.A. (mm ²)	No. of Cores	Nominal Diameters (mm)		INDOOR	OUTDOOR	OUTDOOR	OUTDOOR	UNICLEAT	SINGLE BOLT CLAMP	TWO BOLT CLAMP				
		Under Armour	Overall	BW Gland BW Kit	CW Gland CW Kit	EIW Gland	EIFW Gland							
1.5	2	7.7	12.3	20S	20S/16	20S/16	20S/16	916	1013	-				
	3	8.2	12.8		20S	20S	20S		20S		1316			
	4	8.9	13.5								20	20	20	20
	7	10.6	15.2		25	25	25		25					
	12	13.9	19.4	32				32			32	32	2129	
	19	16.5	22.2		32	32	32		32				2327	
	27	20.1	26.7	32				32			32	32	2839	
	37	22.4	29.2		32	32	32		32				2732	
48	25.9	32.9	32	32				32		32	2732			
2.5	2	9.0			13.6	20S	20S		20S		20S	916	1316	-
	3	9.5	14.1	20	20			20		20			1522	
	4	10.4	15.0										25	
	7	12.5	18.0	25	25			25		25				
	12	16.7	22.4			32	32		32		32	2129		
	19	20.0	26.6	32	32			32		32		2327		
	27	23.9	30.7			32	32		32		32	2732		
	37	27.0	34.0	40	40			40		40		2839		
48	31.3	39.5	40			40	40		40		3238			
4.0	2	10.5		15.1	20S			20S		20S	20S	916	1316	-
	3	11.2	15.8	20		20	20		20				1522	
	4	12.3	17.8										25	
	7	14.8	20.5	25		25	25		25					
	12	20.2	26.8		32			32		32	32	2129		
	19	23.7	30.5	32		32	32		32			2327		
	27	29.1	37.1		40			40		40	40	2732		
	37	32.6	40.8	50S		50S	50S		50S			2839		
48	37.6	46.0	50S		50S			50S		50S	3238			
6.0	2	11.7		16.5		20	20		20		20	1522	1619	-
	3	12.5	18.0	20	20			20		20			1923	
	4	13.7	19.2										20	
10.0	2	14.4	20.1	25	25	25	25	1522	1923	-				
	3	15.5	21.2						25		25	25	25	2129
	4	17.1	22.8											25
16.0	2	16.2	21.9	25	25	25	25	2129	1923	-				
	3	17.4	23.1						32		32	32	32	2327
	4	19.7	26.3											32
25	2	20.1	26.7	32	32	32	32	2129	2327	-				
	3	21.6	28.2						32		32	32	32	2839
	4	23.9	30.7											32
35	2	22.4	29.2	32	32	32	32	2839	2732	-				
	3	24	30.8						40		40	40	40	3238
	4	26.7	33.7											40
50	2	20.8	27.8	32	32	32	32	2129	2732	-				
	3	23.5	30.5						40		40	40	40	2839
	4	27.4	35.4											40
70	2	23.4	30.4	32	32	32	32	2839	2732	-				
	3	27	35						40		40	40	40	3238
	4	31	39.2											40
95	2	27.3	35.5	40	40	40	40	2839	3238	-				
	3	31.1	39.3						50S		50S	50S	50S	3852
	4	35.9	44.3											50S
120	2	29.6	38	40	40	40	40	2839	3238	-				
	3	33.8	42.2						50S		50S	50S	50S	3852
	4	39.5	49.3											50
150	2	32.7	41.3	50S	50S	50S	50S	3852	3846	-				
	3	37.7	47.5						50		50	50	50	4651
	4	43.6	53.6											50
185	2	36.6	46.4	50S	50S	50S	50S	3852	4651	-				
	3	41.9	51.9						50		50	50	50	5157
	4	48.8	59											63S
240	2	41.2	51.2	50	50	50	50	3852	5157	-				
	3	47.6	57.8						63S		63S	63S	63S	5764
	4	55.1	65.7											63
300	2	46	56.4	63S	63S	63S	63S	-	5157	-				
	3	52.6	63.2						63		63	63	63	5764
	4	61	72											75S
400	2	51.1	61.9	63	63	63	63	-	5764	-				
	3	58.6	69.6						75S		75S	75S	75S	6470
	4	68.4	81.3											-



XLPE OR EPR/SWA/POLYMERIC CABLES TO BS6724 : 1997											
With Extruded Bedding and Circular/Shaped Stranded Copper Conductors 600/1000 Volts											
XLPE / EPR				CABLE GLAND/CLEAT TYPE & SIZE							
CABLE CONSTRUCTION				CABLE GLAND/CLEAT TYPE & SIZE							
Conductor C.S.A. (mm ²)	No. of Cores	Nominal Diameters (mm)		INDOOR	OUTDOOR	OUTDOOR	OUTDOOR	UNICLEAT	SINGLE BOLT CLAMP	TWO BOLT CLAMP	
		Under Armour	Overall	BW Gland BW Kit	CW Gland CW Kit	E1W Gland	E1FW Gland				
1.5	2	7.7	12.1	20S	20S/16	20S/16	20S/16	0916	1013	-	
	3	8.2	12.6		20S	20S	20S		1522		1316
	4	8.9	13.3								25
	5	9.7	14.3	32	25	25	2839	2327			
	7	10.6	15.2					32	32		32
	12	13.9	19.4	32	32	32	2839				
	19	16.5	22.2					48	25.9		32.7
	27	20.1	26.7	48	31.3	39.3	3852				
	37	22.4	29.0					48	31.3		39.3
48	25.9	32.7	48	31.3	39.3	3852	3846				
2.5	2	9.0					13.6	20S	20S	20S	20S
	3	9.5	14.1	20	20	20	1522		1619		
	4	10.4	15.0						25	25	25
	5	11.5	16.1	32	32	32	2839	2327			
	7	12.5	17.1					32	32	32	2839
	12	16.7	22.4	40	40	40	3852				
	19	20.0	26.6					40	40	40	3852
	27	23.9	30.7	48	31.3	39.3	3852				
	37	27.0	33.8					48	31.3	39.3	3852
48	31.3	39.3	48	31.3	39.3	3852	3846				
4	2	10.1					14.7	20S	20S	20S	20S
	3	10.7	15.3	20	20	20	20	1522	1619		
	4	11.8	16.4						25	25	25
	5	13.0	17.8	32	32	32	2839	2327			
	7	14.2	19.7					32	32	32	2839
	12	19.3	25.7	40	40	40	3852				
	19	22.7	29.3					40	40	40	3852
	27	27.4	34.4	48	35.9	44.1	3852				
	37	31.2	39.2					48	35.9	44.1	3852
48	35.9	44.1	48	35.9	44.1	3852	3846				
6	2	11.3					15.9	20S	20S	20S	20S
	3	12.0	16.6	20	20	20	20	1522	1619		
	4	13.2	18.7						25	25	25
	5	14.5	20.0	25	25	25	25	2129			
	2	14.9	20.4						32	32	32
3	15.9	21.6	32	32	32	32	2129	2732			
4	17.7	23.4						48	31.3	39.3	3852
5	20.0	26.6	48	31.3	39.3	3852	3846				
10	2	13.2						18.0	20S	20S	20S
	3	14.0	19.5	20	20	20	20	1522	1619		
	4	15.6	21.1						25	25	25
	5	17.2	22.9	25	25	25	25	2129			
	2	18.4	24.1						32	32	32
3	20.1	26.7	32	32	32	32	2129	2732			
4	22.3	28.9						48	31.3	39.3	3852
5	24.7	31.5	48	31.3	39.3	3852	3846				
16	2	14.9						20.4	20S	20S	20S
	3	15.9	21.6	25	25	25	25	1522	1619		
	4	17.7	23.4						25	25	25
	5	20.0	26.6	32	32	32	32	2129			
	2	18.4	24.1						32	32	32
3	20.1	26.7	32	32	32	32	2129	2732			
4	22.3	28.9						48	31.3	39.3	3852
5	24.7	31.5	48	31.3	39.3	3852	3846				
25	2	21.1						27.7	32	32	32
	3	22.6	29.4	32	32	32	32	2839	3238		
	4	25.1	31.9						40	40	40
	5	27.8	34.8	50S	50S	50S	50S	3852			
	2	19.0	25.8						25	25	25
3	21.7	28.5	32	32	32	32	2839	2732			
4	25.0	32.0						50S	50S	50S	50S
5	32.4	40.4	50S	50S	50S	50S	3852				
50	2	22.0						29.0	32	32	32
	3	25.2	32.2	40	40	40	40	2839	3238		
	4	29.5	37.7						50S	50S	50S
	5	37.9	46.3	50S	50S	50S	50S	3852			
	2	25.1	33.1						32	32	32
3	28.8	37.0	40	40	40	40	2839	3238			
4	33.3	41.7						50S	50S	50S	50S
2	27.9	36.1	40	40	40	40	2839				
3	32.0	40.4						50S	50S	50S	50S
4	37.5	47.1	50S	50S	50S	50S	3852				
120	2	30.9						39.3	40	40	40
	3	35.9	45.5	50S	50S	50S	50S	3852	3846		
	4	41.6	51.4						50S	50S	50S
	2	34.9	44.7	50S	50S	50S	50S	3852			
	3	40.0	49.8						50S	50S	50S
4	46.4	56.6	63S	63S	63S	63S	3852	3846			
185	2	39.0						49.0	50	50	50
	3	44.9	55.1	63S	63S	63S	63S	3852	5157		
	4	52.6	63.0						63	63	63
	2	43.3	53.5	50	63S	63S	63S	3852			
	3	49.8	60.2						63S	63	63
4	58.0	68.8	75S	75S	75S	75S	3852	6470			
300	2	48.4						59.0	63S	63S	63S
	3	55.8	66.6	63	75S	75S	75S	3852	6470		
	4	65.4	78.1						75	75	75
	2	48.4	59.0	63S	63S	63S	63S	3852			
	3	55.8	66.6						63	75S	75S
4	65.4	78.1	75	75	75	75	3852	7683			

Note : For Cables up to 35mm sq, Conductors are Circular Stranded and for cables 50mm sq and over, conductors are Shaped Stranded



SELECTOR CHART FOR GSWB OR BWB BRAID ARMOUR CABLE TO BS6883:1999 MULTIPAIR INSTRUMENTATION CABLE RATED 150/250 VOLT												
XLPE												
CABLE CONSTRUCTION					CABLE GLAND/CLEAT TYPE & SIZE							
Conductor C.S.A. (mm ²)	No. of Pairs	Configuration	Nominal Diameters (mm)		OUTDOOR	OUTDOOR	OUTDOOR	OUTDOOR	UNICLEAT	SINGLE BOLT CLAMP	TWO BOLT CLAMP	
			Under Armour	Overall	CX or C2K Gland	E1X or E1FX Gland	T3CDS Gland	PX2KX Gland				
0.75	1 Pr	Individually Screened Pairs	7.5	11.5	20S/16	20S/16	20S/16	20S/16	916	1013	-	
	3 Pr		14.2	18.6	25	25	25	25	1522	1619		
	7 Pr		19.0	24.0					2129	2327		
	12 Pr		25.5	30.7	32	32	32	32	2839	2732		
	20 Pr		32.5	39.1	50S	50S	50S	50S	50S	3852		3846
	27 Pr		36.9	44.1								
	37 Pr		41.8	49.2								
0.75	3 Pr	Collectively Screened Pairs	12.9	17.3	20	20	20	20	1522	1619	-	
	7 Pr		17.0	21.7	25	25	25	25		1923		
	12 Pr		22.6	27.6	32	32	32	32	2129	2732		
	20 Pr		28.2	34.7	40	40	40	40	2839	3238		
	27 Pr		32.0	38.8						3846		
	37 Pr		36.1	43.3						50S		50S
	1.0		1 Pr	Individually Screened Pairs	7.9	11.9	20S/16	20S/16	20S/16	20S/16		916
3 Pr		15.2	19.7		25	25	25	25	1522	1923		
7 Pr		20.2	25.1		32	32	32	32	2129	2327		
12 Pr		27.5	33.8		40	40	40	40	2839	3238		
20 Pr		34.7	41.6		50S	50S	50S	50S	50S	3852	3846	
27 Pr		39.4	46.7									
37 Pr		44.8	52.6									63S
1.0	3 Pr	Collectively Screened Pairs	13.6	18.0	20	20	20	20	1522	1619	-	
	7 Pr		18.0	23.0	25	25	25	25	2129	1923		
	12 Pr		24.0	29.2	32	32	32	32	2839	2732		
	20 Pr		29.9	36.7	40	40	40	40		3238		
	27 Pr		34.3	41.2	50S	50S	50S	50S	3852	3846		
	37 Pr		38.6	46.0								50
	0.75		1 Tr	Individually Screened Triples	8.1	12.2	20S/16	20S/16	20S/16	20S/16		916
3 Tr		15.9	21.0		25	25	25	25	1522	1923		
7 Tr		21.4	26.4		32	32	32	32	2129	2327		
12 Tr		28.6	35.1		40	40	40	40	2839	3238		
0.75	3 Tr	Collectively Screened Triples	14.4	18.8	25	25	25	25	1522	1619	-	
	7 Tr		18.8	23.8	32	32	32	32	2129	2327		
	12 Tr		25.3	30.9					2839	2732		
1.0	1 Tr	Individually Screened Triples	8.8	12.8	20S	20S	20S	20S	916	1013	-	
	3 Tr		16.9	21.7	25	25	25	25	1522	1923		
	7 Tr		22.8	27.8	32	32	32	32	2129	2732		
	12 Tr		30.9	37.3	40	40	40	40	2839	3238		
1.0	3 Tr	Collectively Screened Triples	15.2	19.8	25	25	25	25	1522	1923	-	
	7 Tr		20.2	25.3	32	32	32	32	2129	2327		
	12 Tr		26.9	33.6	40	40	40	40	2839	3238		
0.75	1 Qd	Individually Screened Quads	9.4	13.4	20S	20S	20S	20S	916	1316	-	
	3 Qds		18.2	23.0	25	25	25	25	2129	1923		
	7 Qds		25.0	29.8	32	32	32	32	2839	2732		
1.0	1 Qd	Collectively Screened Quads	9.9	13.9	20S	20S	20S	20S	916	1316	-	
	3 Qds		19.6	24.6	25	25	25	25	2129	2327		
	7 Qds		26.7	31.9	40	40	40	40	2839	2732		

SELECTOR CHART FOR UNARMoured XLPE/PVC CABLE TO BS6883:1999 MULTIPAIR INSTRUMENTATION CABLE RATED 150/250 VOLT									
XLPE				CABLE GLAND/CLEAT TYPE & SIZE					
CABLE CONSTRUCTION				CABLE GLAND/CLEAT TYPE & SIZE					
Conductor C.S.A. (mm ²)	No. of Pairs	Configuration	Nominal Overall Diameter	OUTDOOR	OUTDOOR	OUTDOOR	UNICLEAT	SINGLE BOLT CLAMP	TWO BOLT CLAMP
				A2/A2F GLAND	SS2K GLAND	PXSS2K GLAND			
0.75	1 Pr	Individually Screened Pairs	7.5	20S/16	20S/16	20S	-	-	-
	3 Pr		14.2	25	25	25	916	1316	
	7 Pr		19.0	32	32	32	1522	1619	
	12 Pr		25.5	32	32	32	2129	2327	
	20 Pr		32.5	50S	50S	50S	2839	3238	
	27 Pr		36.9	50	50	50	3852	3846	
	37 Pr		41.8	50	50	50	3852	3846	
0.75	3 Pr	Collectively Screened Pairs	12.9	20	20	20	916	1013	-
	7 Pr		17.0	25	25	25	1522	1619	
	12 Pr		22.6	32	32	32	2129	1923	
	20 Pr		28.2	40	40	40	2839	2732	
	27 Pr		32.0	50S	50S	50S	2839	3238	
	37 Pr		36.1	50S	50S	50S	2839	3238	
1.0	1 Pr	Individually Screened Pairs	7.9	20S/16	20S/16	20S	-	-	-
	3 Pr		15.2	25	25	25	916	1316	
	7 Pr		20.2	32	32	32	1522	1923	
	12 Pr		27.5	40	40	40	2129	2732	
	20 Pr		34.7	50S	50S	50S	2839	3238	
	27 Pr		39.4	50	50	50	3852	3846	
	37 Pr		44.8	63S	63S	63S	3852	3846	
	37 Pr		44.8	63S	63S	63S	3852	3846	
1.0	3 Pr	Collectively Screened Pairs	13.6	20	20	20	916	1316	-
	7 Pr		18.0	25	25	25	1522	1619	
	12 Pr		24.0	32	32	32	2129	2327	
	20 Pr		29.9	40	40	40	2839	2732	
	27 Pr		34.3	50S	50S	50S	2839	3238	
	37 Pr		38.6	50	50	50	2839	3846	
0.75	1 Tr	Individually Screened Triples	8.1	20S/16	20S/16	20S	-	-	-
	3 Tr		15.9	25	25	25	916	1316	
	7 Tr		21.4	32	32	32	1522	1923	
	12 Tr		28.6	40	40	40	2129	2732	
0.75	3 Tr	Collectively Screened Triples	14.4	25	25	25	916	1316	-
	7 Tr		18.8	25	25	25	1522	1619	
	12 Tr		25.3	32	32	32	2129	2327	
1.0	1 Tr	Individually Screened Triples	8.8	20S	20S	20S	-	-	-
	3 Tr		16.9	25	25	25	1522	1619	
	7 Tr		22.8	32	32	32	2129	1923	
	12 Tr		30.9	40	40	40	2839	2732	
1.0	3 Tr	Collectively Screened Triples	15.2	25	25	25	916	1316	-
	7 Tr		20.2	32	32	32	1522	1923	
	12 Tr		26.9	40	40	40	2129	2327	
0.75	1 Qd	Individually Screened Quads	9.4	20S	20S	20S	916	-	-
	3 Qds		18.2	25	25	25	1522	1619	
	7 Qds		25.0	32	32	32	2129	2327	
1.0	1 Qd	Collectively Screened Quads	9.9	20S	20S	20S	916	-	-
	3 Qds		19.6	25	25	25	1522	1923	
	7 Qds		31.7	40	40	40	2839	2732	

NEWCASTLE (Headquarters)

CMP Products
Glasshouse Street, St Peters
Newcastle Upon Tyne
NE6 1BS, England
Tel: +44 191 265 7411
Fax: +44 191 265 0581
E-Mail: cmp@cmp-products.com

DUBAI (British Engines (Middle East) FZE)

CMP Products Middle East Office
P.O. Box 61363, Jebel Ali Free Zone
Jebel Ali, Dubai, United Arab Emirates
Tel: +971 4 887 1012
Fax: +971 4 887 1015
E-Mail: meoffice@cmp-products.com

PERTH, WA

CMP Products
Unit 3 - 22 Harlond Avenue
Malaga, WA 6090
Australia
Tel: +61 (0) 447 440 370
Email: perthoffice@cmp-products.com

HOUSTON (British Engines Texas Inc)

CMP Products
5829W Sam Houston Parkway N
Suite 205 Houston, Texas 77041, USA
Tel: +1 713 462 2073
Fax: +1 713 462 2076
E-Mail: houstonoffice@cmp-products.com

PUSAN

CMP Products (Korea) Ltd
8-810, Digital Valley,
132-7, Gamjeon-dong, Sasang-gu
Pusan, South Korea
Tel: +82 51 317 3147
Fax: +82 51 317 3148
E-Mail: pusanoffice@cmp-products.com

SINGAPORE

CMP Products (S.E.A) Pte Ltd.
21 Toh Guan Road East, #09-03,
Toh Guan Centre
Singapore 608609
Tel: +65 6466 6180
Fax: +65 6466 9891
E-Mail: seaoffice@cmp-products.com

SHANGHAI

CMP Products (Representative Office)
Room 2407, Building C, Thompson Centre
No 188 Zhangyang Road, Pudong District
Shanghai, 200120 P.R. China
Tel: +86 21 5054 0096
Fax: +86 21 5054 0676
E-Mail: shanghaioffice@cmp-products.com

Available from:

For any other requirement not listed within the CMP standard catalogue range, please feel free to convey your requirements to the nearest office detailed above, as CMP prides itself in having the ability and flexibility to provide solutions that meet the very needs of industry. Whether your application is for General Purpose Industrial, Ordinary Locations, Marine and Wet Locations, or Hazardous Locations, CMP delivers the solution at the right place, the right time and the right price.

